



**Safety
Codes
Council**

Alberta 
Government



BARRIER-FREE DESIGN GUIDE

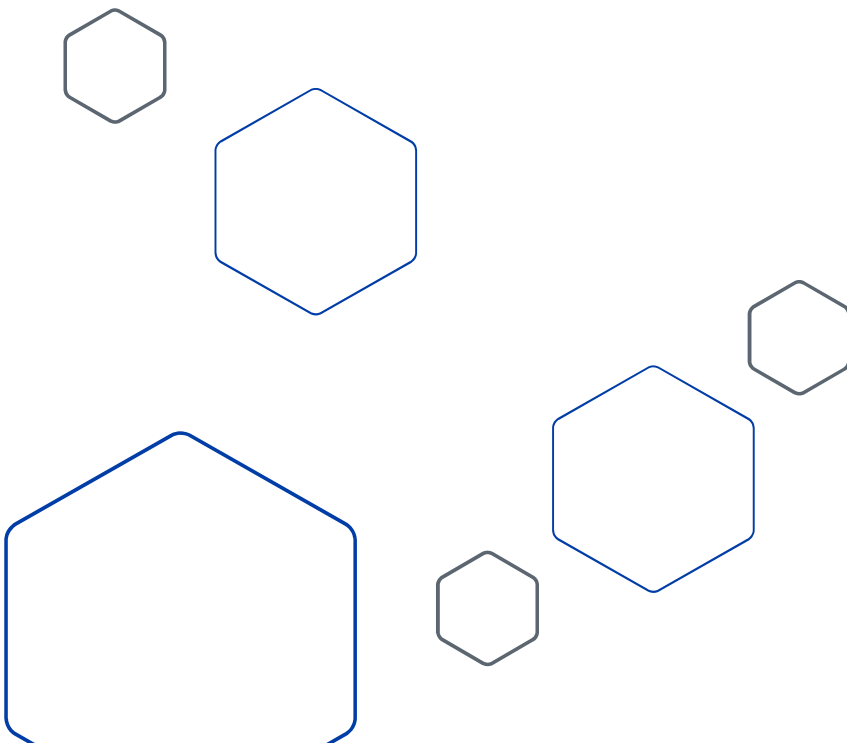

**Fifth Edition
Summer 2017**

**Design for Independence and
Dignity for Everyone**

Vision, Hearing, Communication,
Mobility, Cognition

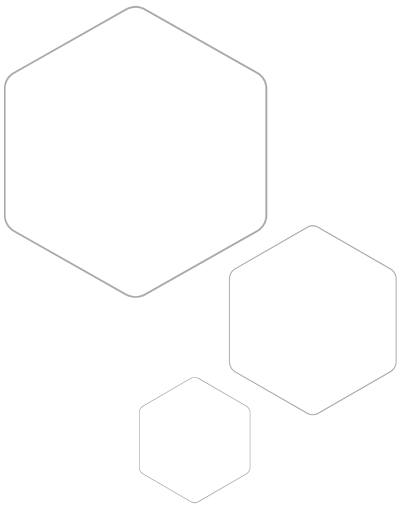

Barrier-Free Design Guide

Based on the Alberta Building Code 2014

For permission to reproduce all
or portions of this book, please contact:

Safety Codes Council

Phone: (780) 413-0099 or 1-888-413-0099

Fax: (780) 424-5134 or 1-888-424-5134

www.safetycodes.ab.ca

Fifth Edition

Published June 2017

Acknowledgments

We wish to acknowledge the following individuals and organizations who have contributed to the content and design of this Barrier-Free Design Guide.

Calgary Apartment Association

Mary Aubrey

Multiple Sclerosis Society, Alberta Division

Bob Coyne

Alberta Hotels & Lodging Association

Tracy Douglas-Blowers

Sage Seniors' Association

Michael Francon

Alberta Construction Association

Stan Lennox

Alberta Association of Architects

Barry McCallum

Canadian Paraplegic Association

Ross Norton

**Canadian Hard of Hearing Association/
Edmonton Branch**

Lee Ramsdell

**Glenrose Rehabilitation/Communication
Disorders**

Briana Strachan

Public Member

Yvette Werenka

Building Sub-Council Liaison

Russell Croome, Deputy Fire Chief
City of Edmonton

ABOA

David Flanagan, City of Edmonton
David Morton, City of Calgary

Safety Codes Council

Danielle Paradis

Compiled and Written by Linnie Tse, Alberta Municipal Affairs

Edited by Jerry Cowan

Illustrations by Graphos

Design by Mike Roshuk, Safety Codes Council

Section 11 Outdoor Spaces is reprinted with permission from the City of Markham Accessibility Guidelines (2011) Sections 6.15 - 6.20 & the City of Ottawa Accessibility Design Standards, 2nd ed. (2015) Sections 6.14 - 6.19.

Preface

The Codes for barrier-free design requirements exist to allow proper and safe access and use of buildings, facilities, and open areas. Designers and builders **must comply with the requirements of the current edition of the Alberta Building Code** prior to construction in order to avoid errors and costly renovations. The Codes for barrier-free design exist to regulate a proper and safe outcome for accessibility.

Section 3.8 of the Alberta Building Code (ABC) 2014 sets forth the technical requirements for barrier-free design. Section 3.8. and other applicable Codes apply to all new construction, additions to existing buildings, buildings undergoing renovation, or changes in use. The current requirements in the ABC are not applied retroactively to existing buildings.

The purpose of this Guide is to explain the intents and objectives of each Code, as well as to recommend best practices where accessibility and safety are concerns to seniors and persons with disabilities.

This Guide provides:

- Alberta Building Code 2014 requirements in **BLUE** text.
- The intent and objectives of articles, sentences, clauses, and sub-clauses.
- Recommendations for Best Practices.
- Illustrations included as **examples only** for the requirements for barrier-free design.
- Requirements for Adaptable Dwelling Units (in housing projects supported by Government funding in part or in whole).
- Recommendations for barrier-free or universally designed private dwelling residences.
- Design basics for seniors and people with physical, sensory, and intellectual disabilities and bariatrics in order to further understanding of the need for well-designed accessible environments.
- Provisions for accessibility in the vicinity of construction sites.

Note: Some important changes in the ABC 2014 to be aware of: Article 3.8.2.2. Parking, Article 3.8.3.3. Doorways and Doors, and Subsection 3.8.4. Adaptable Dwelling Units.

There are building types that are exempt from barrier-free requirements: single-family dwellings and industrial sites (e.g., warehouses, workshops, and electrical substations). A complete list of exemptions can be found in Sentence 3.8.1.1.(1) of Division B, and a list of occupancy classifications (e.g., Group F, Division 1) are in Appendix 4 of this Guide.

Designated historical sites may also be exempt from meeting barrier-free requirements. An application for the inclusion of barrier-free access in a building designated under the Historical Resources Act must be submitted to the Minister of Culture.

Exemption from building code

51(1) The Minister may make regulations exempting Registered Historic Sites or Provincial Historic Sites from the application of any provision contained in any building code that would otherwise be applicable pursuant to any Act, regulation or municipal bylaw when the enforcement of that provision would prevent or seriously hinder the preservation, restoration or use of all or any portion of the site or monument.

(2) A regulation under subsection (1) may be general or particular in application.

The evaluation process involves: consultation with the stakeholder group, evaluation of access requirements; identification of the unique character of the site; and development of options to meet the intent of the Code and arrive at a solution that will work within the historical and economic scope of the project. (Also refer to: Standards and Guidelines for the Conservation of Historic Places in Canada.)

The Chief Building Administrator and the Barrier-Free Policy Administrator will jointly review applications for relaxation of barrier-free requirements. The burden rests with the applicant to prove that the request for relaxation of requirements should be granted by demonstrating that a) the specific requirements are unnecessary, or b) extraordinary circumstances prevent conformance.

The Government of Alberta requires reasonable access to facilities for seniors and people with disabilities so that the same opportunities exist for everyone to be active, independent, and safe within their chosen communities. This includes:

- Safe paths of travel to, within, and through buildings and facilities that include but are not limited to doorways, ramps, elevators, and pedestrian pathways such as hallways and emergency exits.
- Access to rooms or suites within facilities, including but not limited to office areas, conference facilities, dining establishments, washrooms and recreational areas, such as swimming pools, ice rinks, theatres, etc.
- Safe paths of travel between facilities and public streets, pathways, sidewalks, parking areas, passenger loading and unloading zones, and bus stops.
- Hotel/lodging accommodations.
- Picnic areas.

The Barrier-Free Sub-Council would like to hear from you. Please let us know if you find this Guide helpful. Your feedback and suggestions can be sent to:

**Safety Codes Council
Barrier-Free Sub-Council**

Phone: (780) 413-0099 or 1-888-413-0099
Fax: (780) 424-5134 or 1-888-424-5134
sccinfo@safetycodes.ab.ca
www.safetycodes.ab.ca

Or

**Alberta Municipal Affairs
Barrier-Free Policy Administrator**

10155 102 Street, 16th Floor
Edmonton, Alberta, Canada
T5J 4L4
Toll Free: 1-866-421-6929
safety.services@gov.ab.ca
www.municipalaffairs.alberta.ca

The Barrier-Free Design Guide has been updated by Alberta Municipal Affairs with the assistance of the Safety Codes Council, the Barrier-Free Council and its stakeholders upon the request of the Barrier-Free Council. This Guide is developed to assist designers, builders and other Alberta Building Code users to meet and possibly exceed the current minimum barrierfree design standards and practices.

The Government of Alberta and the Alberta Safety Codes Council would like to acknowledge and thank the City of Markham and the City of Ottawa for permitting the inclusion of their Guidelines and Standards for outdoor spaces in this edition of the Barrier-Free Design Guide.

Disclaimer: This document was produced for information purposes only. The user of this information is solely responsible for assessing and determining whether the information is appropriate for their own use. Alberta Municipal Affairs and its agents, employees and contractors, and the Safety Codes Council and its agents, employees and contractors do not make any warranties or guarantees as to the accuracy or completeness of any information, and does not accept any liability whatsoever for any defect, deficiency, error, or omission in any statement or information contained in, or in any way related to, the use of the information contained in this guide.

The information in this guide is not intended to provide legal or other professional advice. If legal or other professional expertise is required with respect to a specific issue or circumstance, the services of a competent professional should be sought.

Table of Contents

Acknowledgments		I
Preface		II
1	General Application of Barrier-Free Design	1
	Application of Barrier-Free Requirements	1
	Occupancy Requirements	2
	Areas Requiring Barrier-Free Path of Travel	2
	Barrier-Free Path of Travel	5
	Visitable Housing (or visitability)	8
2	Barrier-Free Relaxations	11
	Relaxations	11
	Allowances	13
3	Site Development	15
	Parking	15
	Parking Access	16
	Passenger Loading Zones	18
	Curbs	19
	Tactile Walking Surface Indicators	21
	Exterior Walks	24
	Ramps	26
4	Circulation	33
	Wayfinding	33
	Circulation	33
	Accessible Entrances	33
	Doorways	36
	Corridors	40
	Overhead Hazard	42
	Stairs, Handrails and Guards	43
	Stairs	43
	Handrails	45
	Elevators and Other Passenger- Elevating Devices	49
	Building Code Variance	51

5	Public Facilities	53
	Stadium and Theatre Seating	53
	Amenities	55
	Other Obstacles	58
	Building Controls	58
	Public Washrooms	59
	Protection from Burns	62
	Mirrors	62
	Faucets	63
	Universal Toilet Rooms	64
	Water Closet Stalls	69
	Water Closets and Urinals	71
	Automatic Flushers for Water Closets and Urinals	72
	Public Shower Facilities	74
	Clear Space at Entrances to Showers	76
	Shower Stalls and Grab Bars	76
6	Adaptable Dwelling Units	79
	Care Facilities, Assisted Living and Seniors Housing	82
7	Residential Requirements	85
	Residential Requirements	85
	Residential Design	85
	Overall Design Elements	86
	Entrances	86
	Exterior Doors	87
	Interior Doorways and Hallways	87
	Windows	87
	Kitchens	88
	Bathrooms	90
8	Fire Safety	95
	Protection on Floor Areas with a Barrier-Free Path of Travel	95
	Areas of Refuge	96
	Fire Alert and Alarm Systems	98
	Installation of Alarms and Lights	101
	Hospitality Industry	101
	Apartment and Condominium Units	101
	Manual Fire Alarm Pull Stations	102
	Tactile Warning Signals	103
	Floor Numbering	104

9	Communication	107
	Entrance Security System	107
	Public Telephones	107
	Telephone Service	107
	Assistive Listening Devices	108
	Assistive Listening Device Systems	110
	Signage	111
	The International Symbol	113
	Additional Symbols	113
	Alternate Forms of Communication for People with Visual Disabilities	113
	Signage	113
	Accessibility for Persons with Visual Disabilities	114
	Accessibility for Persons with Language Difficulties	114
	Directories	114
	Colour Contrast	115
10	Accessibility in Vicinity of Construction Sites	117
	Application of this Code	117
11	Outdoor Spaces	121
	Outdoor Public Use Eating Areas	121
	Recreational Trails, Beach Access Routes and Boardwalks	123
	Recreational Trail Design Checklist	131
	Inclusive Play Spaces	133
	Inclusive Play Space Design Guide	139
	Inclusive Play Space Checklist	146
12	Information and Design Basics for Seniors and Persons with Disabilities	149
	Barrier-Free Design Basics for People who are Deaf	150
	Barrier-Free Design Basics for People who are Deaf-Blind	150
	Barrier-Free Design Basics for People who are Hard of Hearing	150
	Barrier-Free Design Basics for People with Communication and Cognitive Disabilities	150
	Barrier-Free Design Basics for Seniors	150
	Barrier-Free Design Basics for People Using Mobility Devices	151
	Environmental Design Considerations for the Bariatric Population	151
	Doorways/Corridors/Elevators	153
	Accessible Entrances/Ramps	153
	Bedrooms/Private Spaces	154

APPENDIX 1	The Principles Of Universal Design	157
PRINCIPLE ONE:	Equitable Use	157
PRINCIPLE TWO:	Flexibility in Use	157
PRINCIPLE THREE:	Simple and Intuitive Use	157
PRINCIPLE FOUR:	Perceptible Information	157
PRINCIPLE FIVE:	Tolerance for Error	158
PRINCIPLE SIX:	Low Physical Effort	158
PRINCIPLE SEVEN:	Size and Space for Approach and Use	158
APPENDIX 2	(CSA) NON-MANDATORY APPENDIX E - ELEVATOR REQUIREMENTS FOR PERSONS WITH PHYSICAL DISABILITIES (APPLICABLE TO THE CSA B44 ONLY)	161
APPENDIX 3	Occupancy Types	175

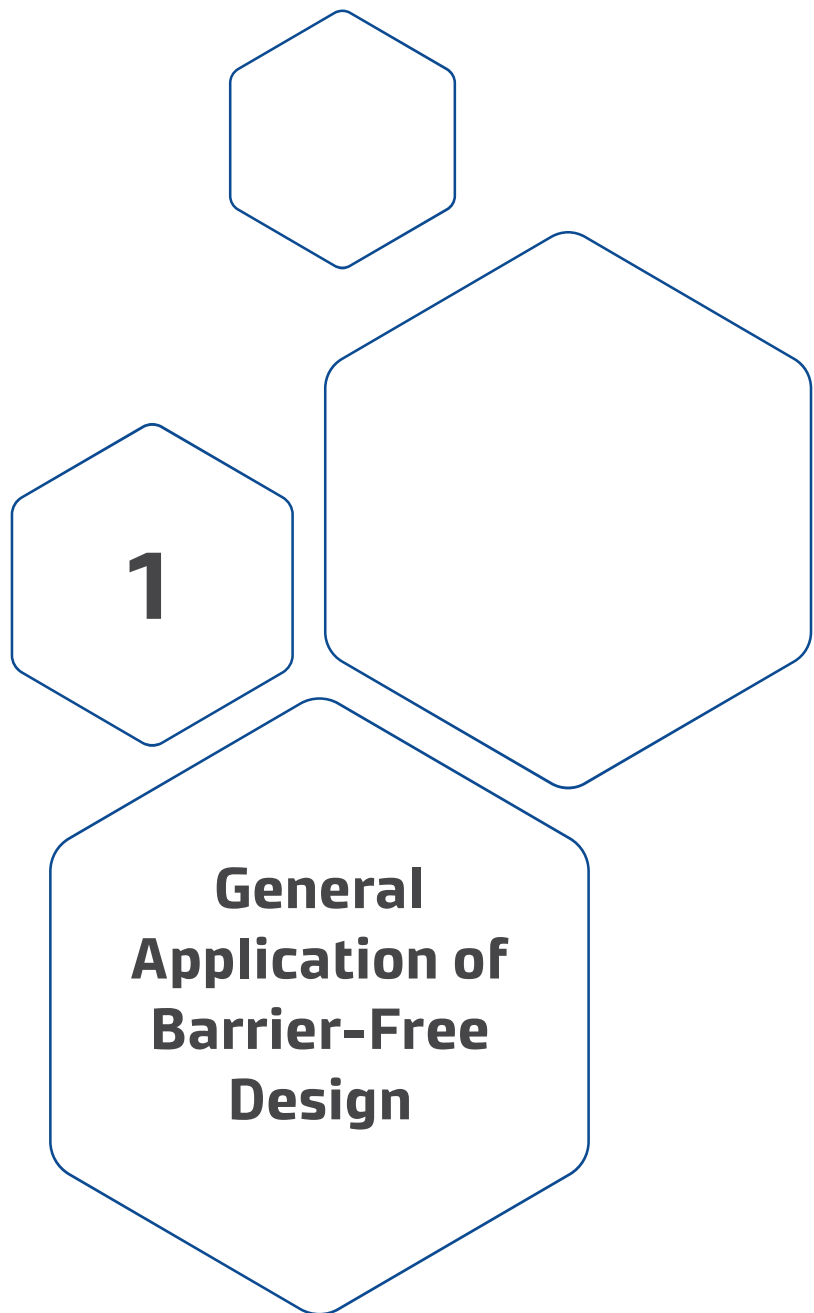



General Application of Barrier-Free Design

Barrier-free design requirements apply to all buildings that are not exempt, and include exterior property that is a part of the building site. Access to the building from the exterior and movement throughout the interior of the building shall be by a barrier-free path of travel.

Application of Barrier-Free Requirements

3.8.1.1. Application

- 1) The requirements of this Section apply to all buildings except
 - a) detached houses, semi-detached houses, houses with a secondary suite, duplexes, triplexes, townhouses, row houses and boarding houses, which are not used in social programs such as group homes, halfway houses and shelters (see A-1.4.1.2.(1), Secondary Suite, in Appendix A of Division A),
 - b) relocatable industrial accommodations,
 - c) buildings of Group F, Division 1 major occupancy, in which only the requirements dealing with hearing sensory disabilities would apply, and
 - d) buildings that are not intended to be occupied on a daily or full-time basis, including automatic telephone exchanges, pumphouses and substations, in which only the requirements dealing with hearing sensory disabilities would apply. (See Appendix A).

Barrier-free design requirements for people with disabilities and seniors apply to all buildings, with the following exceptions:

- Single-family dwelling units not being used for social programs such as group homes, daycares, seniors activities/programs, or transitional programs/services.
 - Relocatable or modular accommodations located on industrial worksites that relate to the operation of that business, such as lunch trailers, sleeping accommodations, recreation, offices, storage, and washrooms.
 - Temporary buildings or facilities (maximum 3 years) may be exempt, such as portable or modular classrooms.
 - Industrial buildings that are used to park/repair/manufacture heavy vehicles/equipment/machines or store hazardous materials/products, or that may be harmful to the occupants; the nature of the operation can make barrier-free design for physical limitations unnecessary in the workplace.
- 2) Buildings required to be barrier-free must comply with all requirements designed to assist persons with physical, sensory and developmental disabilities.

**Note**

Thoughtful design means to consider how a space is to be used by the majority of people, including people with various disabilities. The objective is to remove as many barriers as possible. A design or solution that may minimize or eliminate an obstacle for one disability group may become an obstacle for another disability group. For instance, maze entrances to public washrooms were designed as a solution to prevent potential crime. However, tight turns in this maze entrance can be difficult for users of a wheelchair or a scooter to manoeuvre through.

Occupancy Requirements

The application of barrier-free design is required for all areas of occupancy, including common areas in residential complexes (condominiums and apartments) and hotels.

Areas Requiring Barrier-Free Path of Travel

3.8.2.1. Areas Requiring a Barrier-Free Path of Travel

(See ABC Appendix A.)

- 1) Except as permitted by Sentences (2), (4) and (5), a barrier-free path of travel from the entrances required by Sentence 3.8.1.2.(1) and (2) shall be provided throughout all normally occupied floor areas. (See Article 3.3.1.7 for additional requirements regarding floor areas above or below the first storey to which a barrier-free path of travel is required.

A barrier-free path of travel is required to all areas where the public, in general, can be expected to occupy or travel. This includes but is not limited to sport arenas/stadiums, pools and pool areas, conference rooms, community centres/halls, theatres, educational institutions, care facilities, semi-private residential units, hotels/motels, and shopping centres.

The exceptions are as follows:

- 2) A barrier-free path of travel for persons using wheelchairs is not required
 - a) to service rooms,
 - b) to elevator machine rooms,
 - c) to janitors' rooms,
 - d) to service spaces,
 - e) to crawl spaces,
 - f) to attic or roof spaces,
 - g) to mezzanines not served by a passenger elevator, a platform-equipped passenger-elevating device, an escalator, or an inclined moving walk,
 - h) to high-hazard industrial occupancies,
 - i) within portions of a floor area with fixed seats in an assembly occupancy where those portions are not part of the barrier-free path of travel to spaces designated for use by persons using wheelchairs,



SECTION 1

- j) within floor levels of a suite of residential occupancy that are not at the same level as the entry level to the suite,
- k) within a suite of residential occupancy that has not been required by other provisions of this Code to be barrier-free, or
- l) within those parts of a floor area that are not at the same level as the entry level, provided amenities and uses provided on any raised or sunken level are accessible on the entry level by means of a barrier-free path of travel.

Intent

Subclause 3.8.2.1.(2)(l) refers to the provision of amenities and uses on differing floor levels. This clause is often interpreted to mean that if the same service can be accessed from both levels, such as the ability to order the same food from the restaurant while in the bar, then it is deemed accessible. However, the clause uses “and,” not “or,” which means that both must be considered when evaluating the site for a barrier-free path of travel. For example, even though food can be served in the bar, the bar and the restaurant have different uses. As well, if the different levels both offer dining but one level offers a different and/or better view of the scenery, then the amenity is now different. The intent is to avoid discrimination and encourage equal participation by providing the same choices to everyone.



Note

Where elevated areas exist, ramps shall be designed according to Article 3.8.3.4. Ramps, in order to create inclusion and equality.

- 3) Unless a barrier-free path of travel is not required in an assembly occupancy by Clause (2)(i), the number of spaces designated for use by persons using wheelchairs within rooms or areas with fixed seats shall conform to Table 3.8.2.1. and be dispersed
 - a) in each floor level of seating,
 - c) in each price range of seating, and
 - d) in each viewing section of seating.

(See Article 3.8.3.6. for the design requirements.)

Intent

Wheelchair spaces are to be provided on each level and in each area or section on that level of seating. This should effectively address the issue of the price variance that may exist from section to section and at each level along a barrier-free path of travel. Most theatres, stadiums, arenas, and gymnasiums are able to place at least 2 wheelchair spaces side-by-side.

Accessible seating should be located on a barrier-free path of travel for ease of access to washrooms, concessions, and other services, as well as exits for egress in case of emergency.

For more information, see Section 5: Public Facilities in this Guide.

3.8.2.1. Areas Requiring a Barrier-Free Path of Travel

- 4) Except as provided in Sentence (5), Sentence (1) does not apply to any storey, not more than 600 m² in area, above or below the first storey of a building that does not exceed two storeys in building height.
- 5) Sentence (1) does not apply to any storey above or below the first storey in a building of residential occupancy that is
 - a) not more than 3 storeys in building height,
 - b) not more than 600 m² in building area, and
 - c) is not served by a passenger-type elevator or other platform-equipped passenger-elevating device.



Best Practice

Sentence (4) reads that a barrier-free path of travel does not apply to storeys above or below the first storey of a building not more than two stories high, and Sentence (5) does not require access to storeys in a building, developers and/or owners are encouraged to provide access to all storeys that serve the public by including a barrier-free path of travel throughout the building.

Barrier-free access to a second storey or a basement can be achieved by using design alternatives such as providing a passenger-elevating device, which may be a platform stair lift or a vertical lift similar to an elevator (refer to Article 3.8.3.5.), or a ramp that complies with Article 3.8.3.4. of the Alberta Building Code.

Commercial businesses, recreational facilities (including but not limited to climbing walls, pools, and race tracks) and all places where people assemble will greatly benefit from the application of barrier-free requirements. The rapidly increasing number of seniors and people with varying disabilities, even parents with strollers, need the opportunity to access services they have always frequented (e.g., restaurants, salons, financial institutions) or would like to frequent. Barrier-free access is required to all non-exempt suites and rooms of lodgings, as well as to the bathrooms within the units. In addition, Article 3.7.2.9. requires that hotels/motels install grab bars around bathtubs for safety.

Some examples of where barrier-free access is required:

- rooms or areas that serve the public or are designated for use by visitors, including areas in assembly occupancies with fixed seats, display areas, and merchandising departments,
- rooms or areas for student use in assembly occupancies,
- general-work areas, including office areas,
- general-use or general-service areas, including shared laundry areas in residential occupancies, recreational areas, cafeterias, lounge rooms, lunchrooms, and infirmaries,
- sleeping rooms in hospitals and nursing homes,
- passenger elevators or elevating devices conforming to Article 3.8.3.5.,
- public washrooms described in Article 3.8.2.3.,



SECTION 1

- any facility required by this Section to be designed to accommodate persons with physical or sensory disabilities, and
- service counters used by the general public (e.g., ticket counters, refreshment stands, drinking fountains, cafeteria counters, check-out counters, bank service counters).

The provision of barrier-free access to amenities and facilities applies to, among other areas: food, beverage, and entertainment facilities within restaurants; smoking and non-smoking areas permitted in accordance with local regulations; and window areas providing a view of an exterior attraction.

Accessibility, in general, is required in all normally occupied spaces.

Barrier-Free Path of Travel

3.8.1.3. Barrier-Free Path of Travel

- 1) Except as required elsewhere in this Part or as permitted by Article 3.8.3.3. pertaining to doorways, the unobstructed width of a barrier-free path of travel shall be not less than 920 mm.

An unobstructed path of travel will minimize or eliminate the likelihood that a person who requires the use of a mobility device will require the assistance of another person to aid in his/her movement through a building. The minimum width that should be considered for the movement of a person using a wheelchair is 920 mm; however, this width will not allow a person or another wheelchair to pass a person in a wheelchair with ease. If possible, it is recommended that twice the required width for a barrier-free path of travel be designed and implemented, especially if the path of travel is long.

Barrier-Free path of travel may include:

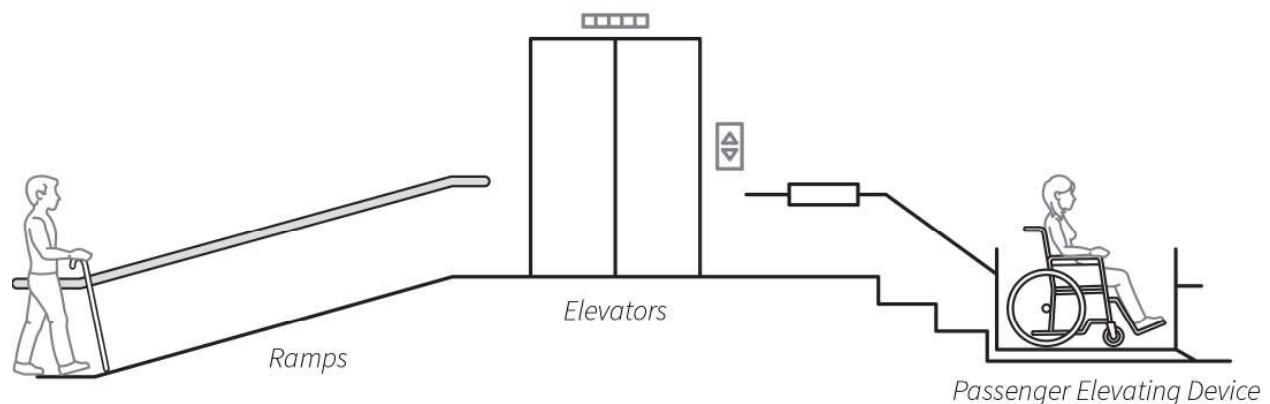

- 2) Interior and exterior walking surfaces that are within a barrier-free path of travel shall
 - a) have no opening that will permit the passage of a sphere more than 13 mm in diam.,
 - b) have any elongated openings oriented approximately perpendicular to the direction of travel,
 - c) be stable, firm and slip-resistant,
 - d) be bevelled at a maximum slope of 1 in 2 at changes in level not more than 13 mm, and
 - e) be provided with sloped floors or ramps at changes in level more than 13 mm.

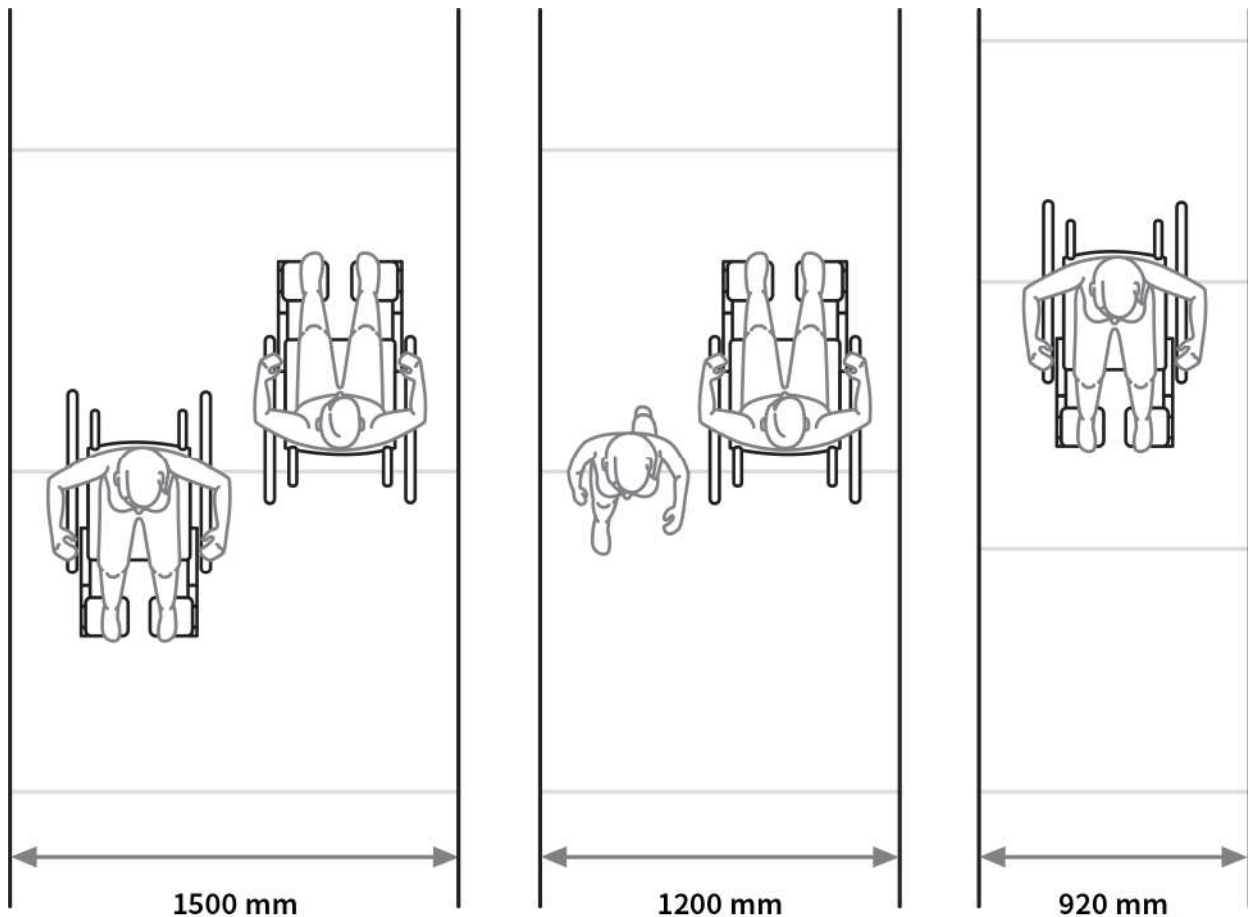

If the gratings have elongated openings, they shall be placed so the long dimension is perpendicular to the direction of travel. Grates shall not have any opening larger than 13 mm in diameter (most walkers, canes, walking sticks, and crutches have a diameter of 25 mm or greater). This would likely prevent a person from becoming injured by or trapped on a walking surface.



Openings larger than **13 mm** may catch wheelchair wheels or canes

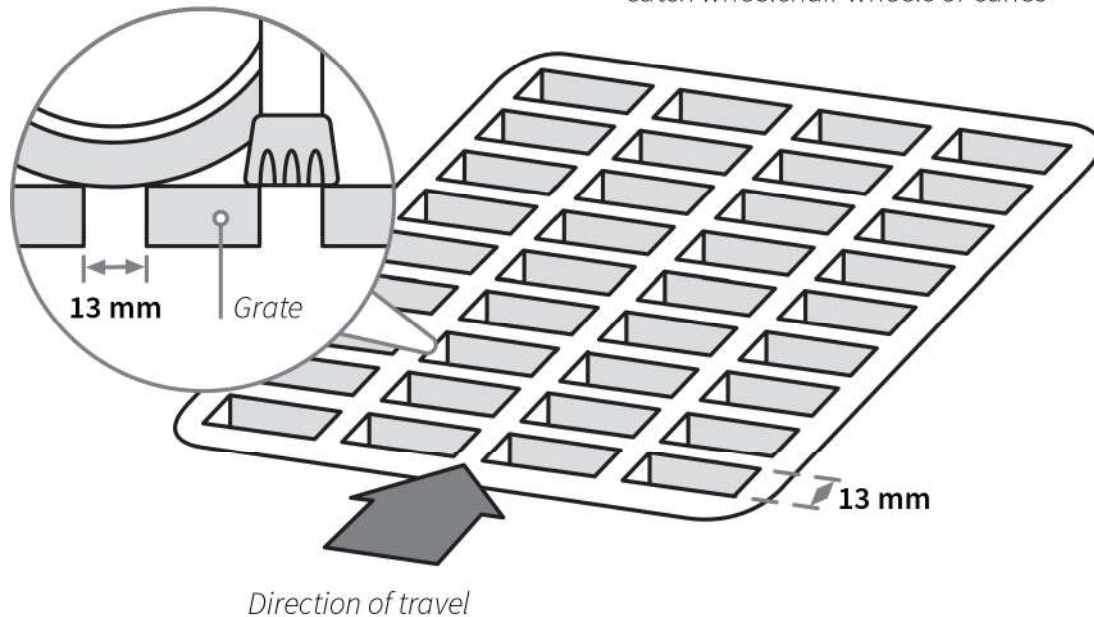

- 3) A barrier-free path of travel is permitted to include ramps, passenger elevators or other platform-equipped passenger-elevating devices to overcome a difference in level.

In a barrier-free path of travel, the provision of ramps at a change in levels of greater than 13 mm will allow for seamless movement from one area to another. Floor surfaces, walks, ramps, stairs and curb ramps in a barrier-free path of travel shall be stable, firm, and slip-resistant in order to help prevent injury. If a ramp is too steep for a person in a manual wheelchair or a person requiring the use of a walker to climb, then a platform-elevating device or elevator is necessary to eliminate the need for individuals to gain assistance in order to negotiate levels.

**Note**

A design or solution that may minimize or eliminate an obstacle for one disability group may become an obstacle for another disability group. For instance, the installation of a gently sloping curb cut/ramp with no lip for persons in wheelchairs removes one of the sidewalk/street reference points for persons who are blind or visually impaired. A steeper slope, a small lip and deep grooves running parallel with the slope of the ramp are often used to mark the street location, making the solution cane-detectable.

3.8.1.4. Access to Stores Served by Escalators and Moving Walks

- 1) In a building in which an escalator or inclined moving walk provides access to any floor level above or below the entrance floor level, an interior barrier-free path of travel shall also be provided to that floor level. (See Appendix A.)

Malls and department stores often rely on escalators to move people from one storey to another. Where escalators are provided for the movement of people from one level to another, elevators or passenger-elevating devices shall also be provided. On a sloping site, a person using a wheelchair might be able to gain access to another level by means of an exterior walkway; however, this arrangement does not meet the intent of the Code. A person using a wheelchair should not be required to travel outside the building to gain access to another level. Such buildings require elevators or platform-lift devices, and their locations shall be clearly indicated.

In creating a barrier-free path of travel for persons with visual disabilities, careful consideration should be given to a visual and tactile/textural warning system on escalator steps and floor surfaces at the top and bottom of the escalator. This will help to orient the user.

Safety Code for Elevators and Escalators

ASME A17.1-2007/CSA B44-07-Safety Code for Elevators and Escalators (Bi-national Standard, with ASME A17.1).

6.1.3.5.6 Step Demarcation

There shall be demarcation lines on the step tread along the back of the step to delineate the division between steps. These lines shall be marked by a yellow strip with a minimum of 38 mm and a maximum of 50 mm in width. There shall be demarcation lines on the step tread along the sides of the step. These side lines shall be yellow and at least 13 mm wide and shall not exceed 50 mm in width. (Also see CSA 6.1.3.5.1(b).)

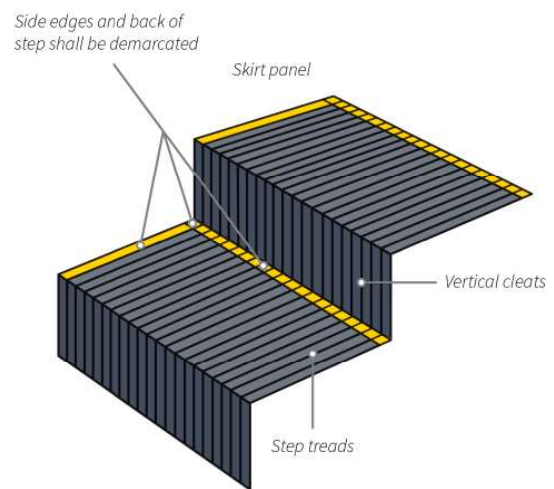

Visitable Housing (or visitability)

The concept of designing and building homes with basic accessibility features will provide easy access on the main level for everyone, including seniors and people with physical disabilities. Visitability promotes inclusion and social integration of people with disabilities, including seniors, to participate more fully within their communities when homes are designed with these accessibility features on the main floor:

- No-step entrance at the front (preferred), back, or side.
- Wider doorways (min 900 mm) and hallways (900-1200 mm) on a barrier-free path of travel.
- Wheelchair accessible bathroom that includes grab bars and a min 1500 mm turning diameter.

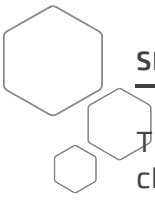

SECTION 1

The advantage of this design concept is that it is convenient for everyone: those with children in strollers; movers of large and/or heavy pieces of furniture or equipment; and people with mobility concerns, including the elderly and people who experience temporary disabilities that may require the use of a wheelchair or crutches. Access is more comfortable when easy visitation is incorporated into the home design from the outset.

This would eliminate the frustration of renovation, especially when the built environment and/or the costs may be prohibitive.

For more information, see www.VisitAbleHousingCanada.com

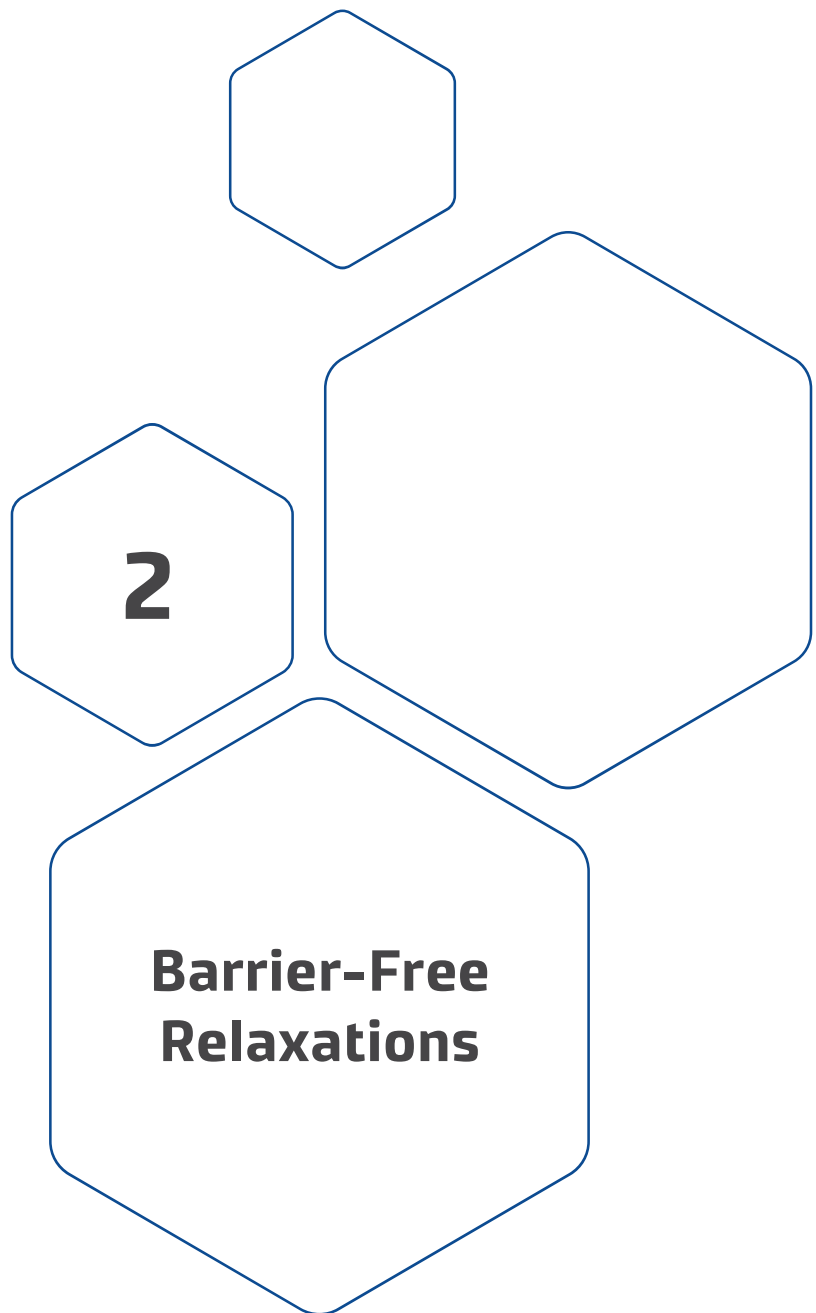



Barrier-Free Relaxations

Division C, Part 2, Administrative Provisions

Relaxations

2.2.1.4. Barrier-Free Relaxations

- 1) The Chief Building Administrator may grant relaxation to one or more of the requirements of Section 3.8., “Barrier-free Design” if an owner can demonstrate to the satisfaction of the Chief Building Administrator that:
 - a) the specific requirements are unnecessary, or
 - b) extraordinary circumstances prevent conformance.

New construction can easily comply with all current code requirements. Thus, all additions and new buildings will automatically be denied relaxation from any of the barrier-free design requirements. Applications being made outside the scope as stated will not be granted. The permission to waive a barrier-free path of travel for access by persons using wheelchairs to certain specified areas of a building is not intended to waive all accessibility requirements for persons with other disabilities. For example, persons with visual or hearing disabilities who do not require the use of a wheelchair can be expected to be able to move throughout a building.

The Building Administrator, in consultation with the Barrier-Free Administrator, may issue a barrier-free relaxation if the owner can demonstrate the barrier-free requirements are unnecessary. This condition is interpreted to mean that

1. an alternative solution providing approximately equivalent or greater safety performance to the barrier-free access code requirements is being proposed; or,
2. the building project is equivalent to one of the exempted classes of buildings described under Article 3.8.1.1. and the appendix to this Article.

The Building Administrator, in consultation with the Barrier-Free Administrator, may issue a barrier-free relaxation if the owner can demonstrate extraordinary circumstances prevent conformance. This condition is interpreted to mean that relaxations will only be granted where no practical alternative can be found.

Barrier-free design requirements do not apply to certain industrial uses, which by nature of their operation, may pose risks to their occupants due to the use of hazardous materials and processes. Some special purpose buildings in heavy industries often require grade separations and other features essential to their functioning, but not compatible with barrier-free design and accessibility. Other special purpose buildings may be partially exempt from barrier-free design requirements, such as barrier-free design for persons with hearing or visual disabilities but not for persons with physical disabilities. Exemptions are listed in Sentence 3.8.1.1.(1) Application, Sentence 3.8.2.1.(2) Areas Requiring a Barrier-Free Path of Travel, and Sentence 3.8.3.13.(2) Showers.

Article 3.8.1.1.(1) under Application allows for the authority having jurisdiction the discretion to assess building projects as exempt or partially exempt from barrier-free design requirements provided the building project meets the conditions or description described under 3.8.1.1.(1). The following occupancies or uses may be assessed as exempt from the barrier-free design requirements and therefore do not require a barrier-free design relaxation:

Other exemptions to the provision of barrier-free design requirements for new and renovations include, but are not limited to, the following:

- Fire & EMS dormitories, including washrooms and showers
- Industrial buildings used for heavy equipment maintenance and/or storage
- Workers' facilities or camps located on industrial sites, e.g., drilling or mining sites
- Waste Management Facilities
- Abattoirs
- Recycling Centres-operations/sorting areas
- Food/beverage service kiosks
- Limited-use, limited-access washroom facilities, e.g., transit turnarounds
- Portable/modular classrooms as overflow for schools, where barrier-free facilities are provided elsewhere.
- Temporary structures-where barrier-free design requirements are shown to be unnecessary.
- Showers in business and personal services occupancy where the showers are not required for provision of hygienic services related to the business.
- Existing buildings where it may not be possible to provide a barrier-free path of travel (e.g., access to the 2nd storey); therefore, barrier-free requirements are not necessary.

These occupancy types meet the criterion of “the specific requirements are unnecessary” or “extraordinary circumstances prevent conformance.” If there is any question or concern with other new builds or renovations that may be exempt from compliance with part or all barrier-free requirements, please contact Alberta Municipal Affairs at 1-866-421-6929 or safety.services@gov.ab.ca



Note

The submission of an Application for the Relaxation of Requirements for the Disabled does not guarantee that a relaxation of barrier-free requirements will be granted by the Building Administrator and Barrier-Free Administrator.

The Application for Relaxation must include the Request for Relaxation of Barrier-Free Requirements from the AHJ as proof that the AHJ is aware of your submission to the Province.

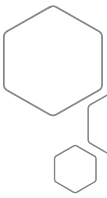

SECTION 2

For further information see the STANDATA for Barrier-Free Relaxations at www.municipalaffairs.gov.ab.ca.

The Application for Relaxation of Barrier-Free Requirements can be found on: www.municipalaffairs.gov.ab.ca/codes_and_permits_accessibility



Note

The applications for relaxation are reviewed based upon the plans submitted to and stamped by the Authority Having Jurisdiction (AHJ) only-no exceptions.

Allowances

Division C, Part 2, Administrative Provisions

2.2.2.4. Dimensional Tolerances

- 1) If life safety will not be reduced, the authority having jurisdiction may accept a minor variation, not more than 2%, of a dimension given in this Code.

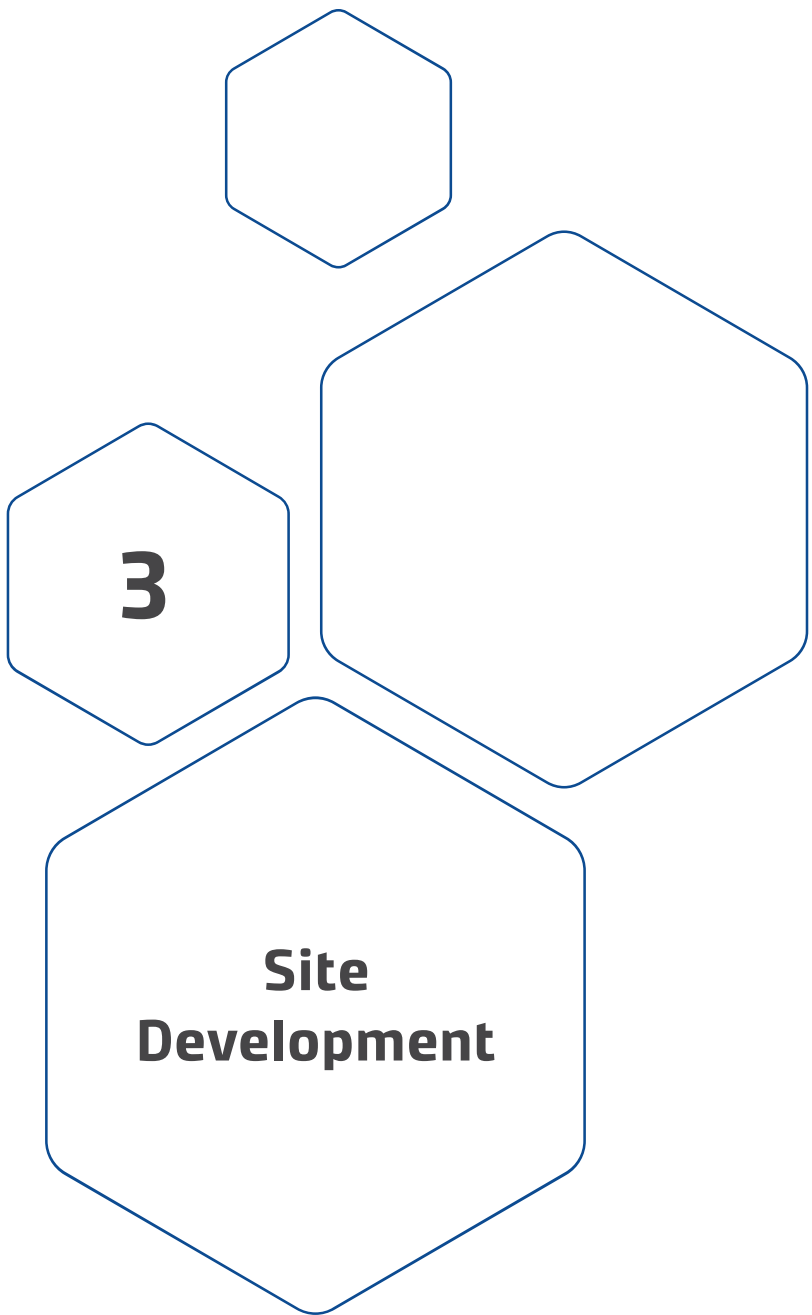

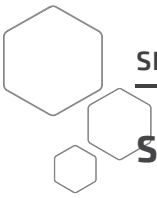

Site Development

Exterior design considerations must ensure a seamless and safe path of travel from the parking area to the building entrance. This path of travel should be functional and safe.

Parking

3.8.2.2. Access to Parking Areas and Stall Design

- 2) Except as provided in Sentence (5), where parking stalls are required by the development authority, made pursuant to the Municipal Government Act, and its regulations, parking stalls for use by persons with disabilities shall be provided in conformance with Table 3.8.2.2.

The Municipal Government Act requires that accessible parking be available for persons with disabilities. Table 3.8.2.2. shows the number of stalls currently required to be designated for use by persons with disabilities.



Best Practice

It is recommended that an additional number of stalls be considered when the purpose or use of the building facilities may cause an increase in the number of seniors or persons with disabilities who require accessible parking, e.g., arenas, grocery stores, medical services, restaurants.

Since 2010, Alberta has issued 100,000+ parking placards. This indicates that a greater number of accessible parking spaces may be required than prescribed in Table 3.8.2.2. One criterion for the issuance of a placard is that the applicant cannot walk more than 50 m.

Table 3.8.2.2.
Designated Parking Spaces
Forming Part of Sentence 3.8.2.2.(2)

Number of Parking Stalls Required	Number of Designated Stalls Required for use by Persons with Disabilities
2 - 10	1
11 - 25	2
26 - 50	3
51 - 100	4
for each additional increment of 100 or part thereof	One additional stall

Parking Access

Article 3.8.2.2. describes the dimensions and characteristics of the parking areas that shall be a) constructed on a hard, level surface (such as asphalt or concrete) and b) located to the nearest curb ramp(s) and/or accessible entrance(s) of the building or business for wheelchairs and other mobility devices to manoeuvre upon and travel safely to/from vehicle/building.

3.8.2.2. Access to Parking Areas

- 1) A barrier-free path of travel shall be provided from the entrance described in Article 3.8.1.2. to
 - a) an exterior parking area, if exterior parking is provided,
 - b) at least one parking level, in a parking structure, and
 - c) to every level in a parking structure served by a passenger elevator.
- 2) Except as provided in Sentence (5), where parking stalls are required by the development authority, made pursuant to the Municipal Government Act and its Regulations, parking stalls for use by persons with disabilities shall be provided in conformance with Table 3.8.2.2.

The barrier-free path of travel from the parking areas to the primary building entrance shall be distinguishable with the use of good lighting, contrasting and continuous colour, and/or change in texture and/or handrails, all of which help to identify the path. Floors within parking structures served by elevators shall also be accessible and designed with safety in mind. Two-storey parking structures under 600 m² need not have elevators or provide access to the basement or second storey.

If parking spaces designated for individuals with disabilities cannot be located close to the elevator or an accessible entrance, then it is necessary that a safe barrier-free path of travel is designated. The accessible parking level should allow a minimum 3 000-mm height clearance in a parkade in order to accommodate larger vehicles (e.g., full-size vans, SUVs, trucks) used by drivers or passengers with a disability.

- 4) A parking stall intended for use by persons using a wheelchair or other mobility aid shall
 - a) be designed as a 2.4 m wide parking stall adjacent to a 2.4 m wide access aisle where the access aisle is demarcated to indicate no parking,
 - b) have a firm, slip-resistant and level surface,
 - c) be clearly marked and identified by
 - i) a vertically mounted sign, located near the centreline of each designated stall, with the centre of the sign between 1 600 to 2 500 mm from the finished surface, and
 - ii) the International Symbol of Access painted on the pavement,
 - d) be located near to or adjoining a barrier-free path of travel leading to the nearest barrier-free entrance, and
 - e) be designed so that parked vehicles shall not obstruct access onto an elevated and level surface.

(See Appendix A).

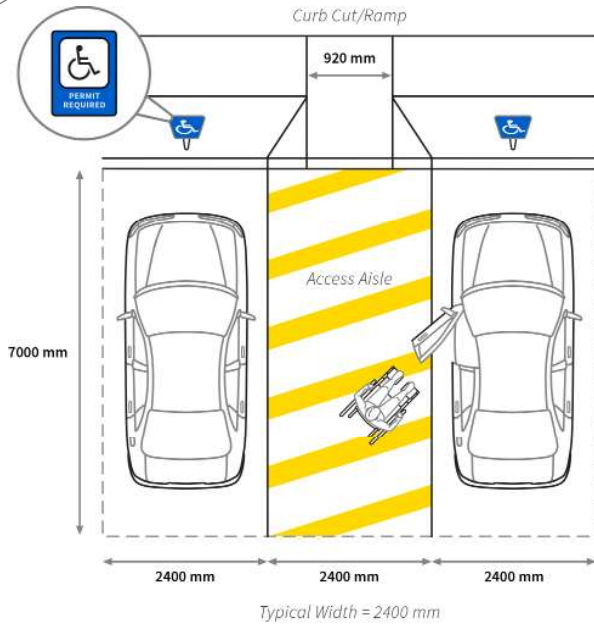

Intent

The accessible parking stall has been reconfigured in the 2014 ABC for two reasons:

- 1) It would be simpler to create designated accessible parking in an existing parking lot. The lines do not need to be repainted in order to create an accessible parking stall because the adjacent stall only needs to be demarcated with diagonal lines to create an access aisle.
- 2) The existing 2 stalls (one of which is demarcated with diagonals) are now effectively 4 800 mm that can now accommodate a larger vehicle such as a full-size van that requires a minimum 4 600 mm in width since access to and from the vehicle is often from the side of the vehicle with a mechanical platform lift that requires more space to load and unload passengers.

The requirement is for 2 adjacent stalls to be designated as barrier-free, including the access aisle.

Note

The 2.4 m wide parking stall is the required minimum width to create a barrier-free or accessible parking stall. However, if municipalities have a greater minimum width for a parking stall as required by their existing bylaws, such as 2.6 m, then that shall be used as the minimum. This will eliminate the need to reconfigure the width of the stall(s).

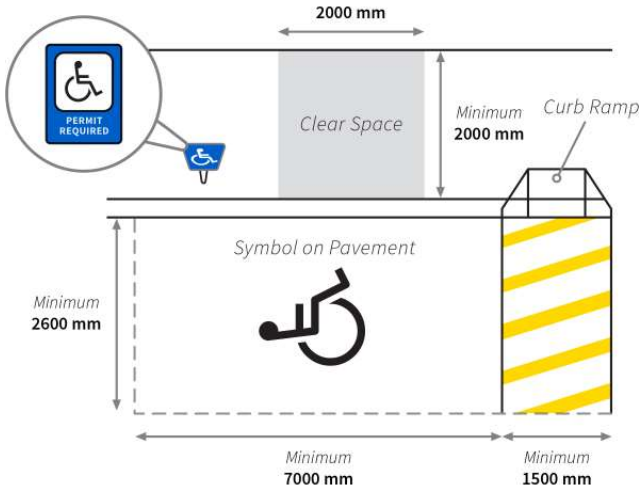

Parking stalls have sometimes been identified with the entire area painted blue, and the accessibility symbol in yellow, to increase visibility. However, this is an unsafe practice because the paint is not slip-resistant under dry or wet conditions. Only the symbol in yellow needs to be located on the pavement of the stall in order to identify it as an accessible parking stall.

An example of a parallel accessible parking stall.

The vertical sign should be located so that it is visible to the driver of a vehicle approaching the space, but does not create a protrusion or a sightline or viewing hazard.

Parking stalls for use by persons with disabilities shall be identified with the International Symbol of Accessibility and should include the words Permit Required.

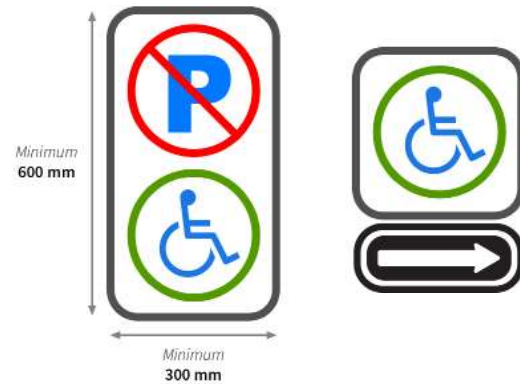

Note

The vertical sign should be officially recognized by the local jurisdiction or be a sign from the Transportation Association of Canada's Manual of uniform traffic control devices for Canada (Ottawa: Transportation Association of Canada, 1998).

Best Practice

Where the location of the designated parking spaces is not obvious or is distant from the approach viewpoint, directional signs should be placed along the route leading to them.

- 5) If adaptable and/or barrier-free dwelling units are provided, one parking stall per unit shall be provided meeting the requirements of Sentence (4).

Every adaptable unit has the potential to become a barrier-free unit, and the occupant(s) of an adaptable dwelling unit or barrier-free unit may require accessible parking. The accessible stalls are calculated and included in the overall design of the parking areas; therefore, all occupants will have a parking stall.

Passenger Loading Zones

3.8.2.2. Access to Parking Areas and Stall Design

- 3) If an exterior passenger loading zone is provided, it shall have
 - a) an access aisle not less than 1 500 mm wide and 6 000 mm long adjacent and parallel to the vehicle pull-up space,
 - b) a curb ramp, where there are curbs between the access aisle and the vehicle pull-up space, and
 - c) a clear height of not less than 2 750 mm at the pull-up space and along the vehicle access and egress routes.

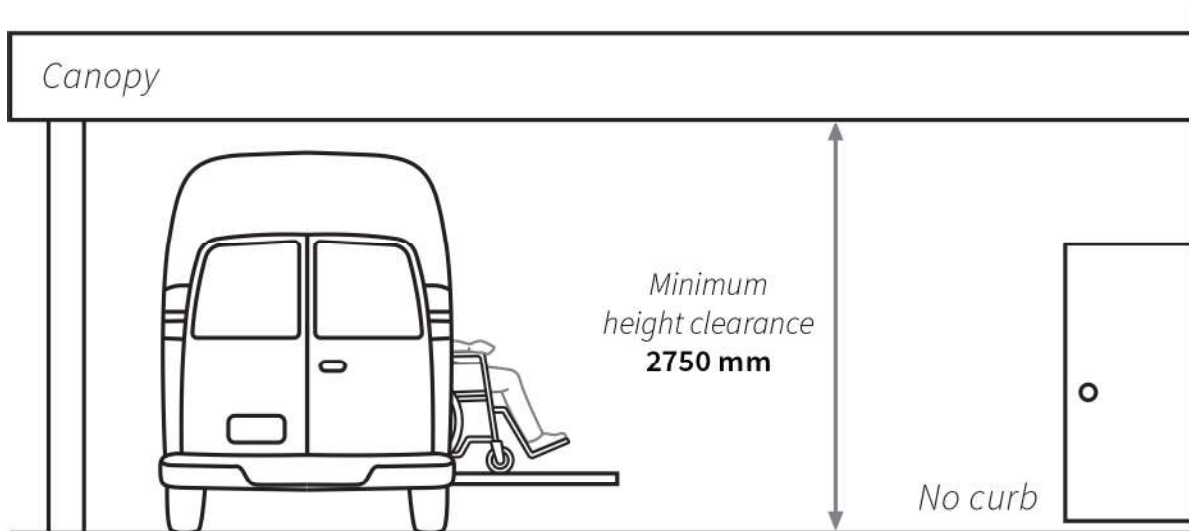

Where a passenger loading zone is provided, accommodations should be made for side or rear loading and unloading operations. The majority of vehicles serving people with disabilities are equipped with side-operating platforms that are 760 mm wide by 1 050 mm long and can discharge patrons at sidewalk level. An area of 2000 x 2000 mm is required beyond the platform to allow a person in a wheelchair to turn around and move in a new direction. A minimum height clearance of 2 750 mm needs to be provided for most van-type transporters.



Note

Municipalities that have specialized transport vehicles may require a minimum of 3.2 m height clearance. In addition, these vehicles need at least 9 m in length to safely pull parallel to a sidewalk and safely load and unload passengers.

Curbs

Sidewalks aligned in front of storefronts and so on are often used as wheel rests for vehicles, causing the vehicle to intrude onto the sidewalk, effectively eliminating the barrier-free path of travel on the pedestrian walkway that is creating a barrier or even a hazard for persons with disabilities, seniors, and others who may use mobility devices, parents with strollers, or others. Therefore, wheel stops should be used to prevent vehicles from intruding onto the walk or path.

Curb Ramps

A curb ramp will allow ease of access on/off a sidewalk, or across a median or traffic island. The curb ramps should be made detectable by persons whose vision is impaired or blind, or even persons with cognitive impairments, with a different surface as an indicator or warning of a change in slope.

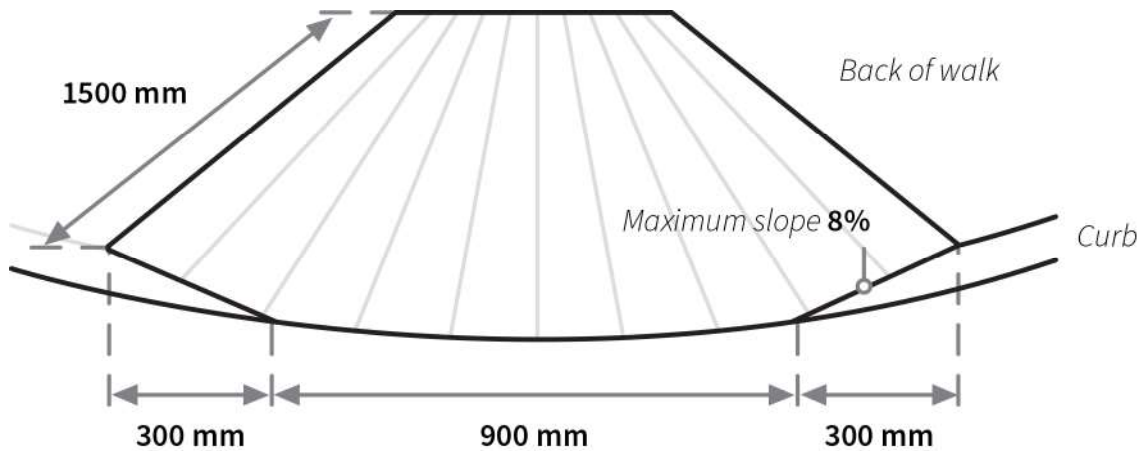

Best Practices

Curb ramps shall NOT be located in front of designated stall because the vehicle will block access to the curb ramp that is a part of the barrier-free path of travel. In a vehicle pull-up space, the curb ramp shall be located between stalls (such as the access aisle) or to the side of or adjacent to the designated stall. If it is a parallel parking space, the curb ramp shall be located behind or in front of the designated stall.

A median that runs the length of a street or parking lot can prevent a person using a wheelchair or other mobility aid from ease of travel, safe travel, or taking a shortcut. The provision of curb ramps for access to a sidewalk or across the median might be necessary. The curb ramp should be at least 760 mm wide and 1 500 mm long.

At street corners, the curb ramp should be pointed in the direction of travel.



Note

The groves on a curb ramp are not an indicator for direction of travel. The groves are meant to assist with moisture run-off.

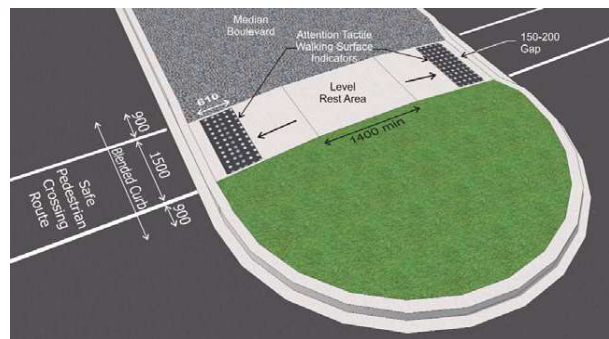
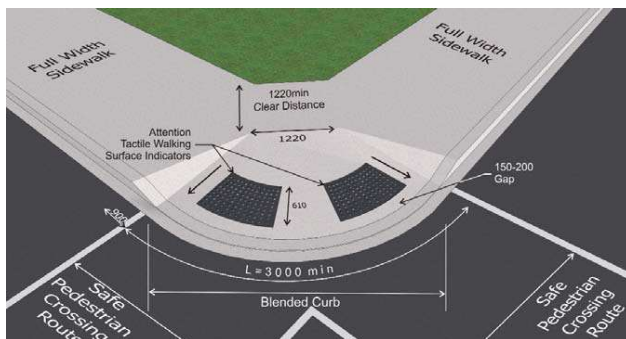

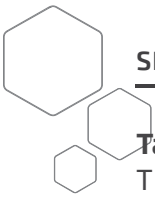

Tactile Walking Surface Indicators

The use of tactile surface indicators (TWSIs) should be used are recommended by the Canadian National Institute of the Blind (CNIB).

Tactile walking surface indicators (TWSIs), sometimes known as detectable warning surfaces, are standardized walking surfaces that convey information to people with vision loss through texture, and, occasionally, through sound.

TWSIs are typically made from inserts (metal, rubber, or plastic) or built directly into concrete. They should have a texture that can be felt underfoot and detected by a long cane. TWSIs should have bevelled edges to decrease the likelihood of tripping.

There are two types of TWSI:

- 1) **Attention TWSIs**, sometimes called **warning** TWSIs, call attention to key hazards, such as the start of a staircase or the edge of a platform in a subway station.
- 2) **Guidance TWSIs**, also known as **wayfinding** TWSIs, provide information about the direction of travel through open spaces. They are designed to guide a person on a designated path of travel.

TWSIs should be colour-contrasted with the surrounding walking surface. Industrial yellow is the preferred colour. However, a light colour on a dark ground surface or a dark colour on a light ground surface also works effectively.

Attention TWSIs

CNIB recommends attention TWSIs consist of circular, flat-topped domes installed on a walking surface.

Attention TWSIs should have the following specifications:

- 1) The height of the flat-topped domes should be 5mm +/- 1mm.
- 2) The diameter of the top of the flat-topped domes should be between 12 mm and 20mm.
- 3) The diameter of the lower base of the flat-topped domes should be 10mm +/- 1mm more than the diameter of the top.
- 4) The distance between the bases of adjacent domes should be a minimum of 15mm.
- 5) The spacing between adjacent flat-topped domes should be adjusted depending on the size of the domes, as shown in the table below. The larger the individual domes, the farther the space between them:

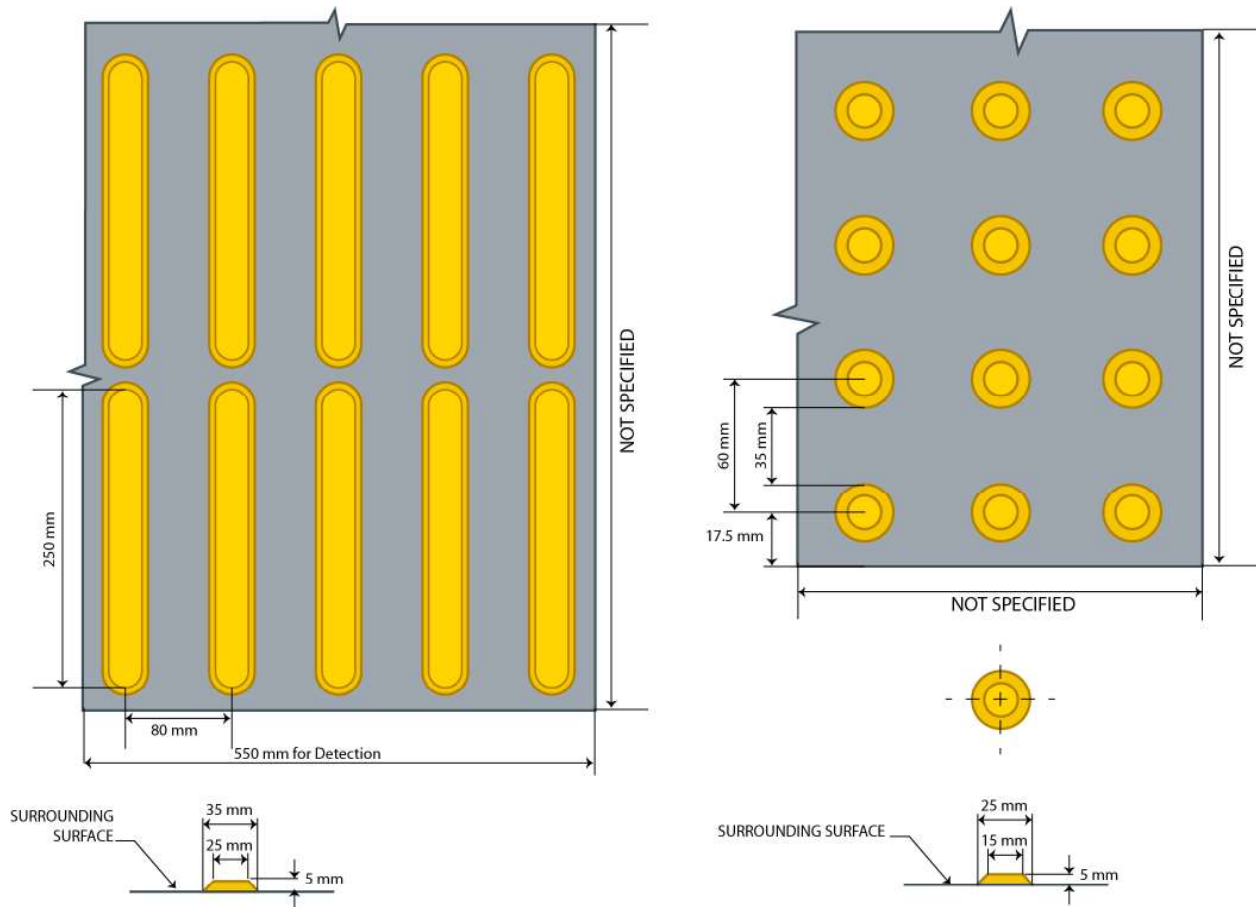

Top diameter of flat-topped domes (mm)	Spacing between the centres of adjacent domes (mm)
12	55 to 61
15	57 to 63
18	60 to 61
20	63 to 68

CNIB recommends attention TWSIs should be used at the following locations:

- Platform edges
- Ferry dock edges
- The edges of reflecting pools and fountains that are unprotected at ground level
- The top of stairs
- Both sides of ground-level railway crossings
- Blended curbs
- At the beginning of ground-level moving walkways (such as those used in airport terminals)

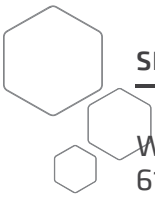

SECTION 3

When attention TWSIs are used on **platforms and ferry docks**, CNIB recommends they begin 610 millimeters before the drop-off, running the full length of all unprotected platform/dock edges that border the drop-off.

At **stairs**, attention TWSIs should commence one tread step before the nosing at the top step, and they should be as wide as the stairs. The attention TWSI alerts a person with vision loss that there is a set of stairs ahead and (s)he should seek the support of a handrail to safely navigate them. The depth of the TWSIs used at the top of stairs should be a minimum of 920 mm.

At **railway crossings**, attention TWSIs should be located so that the edges of TWSIs are 1.8 m minimum and 4.6 m maximum from the centerline of the nearest rail. (Attention TWSIs should be installed in addition to any mechanical barriers that are activated with the arrival of trains.)

Attention TWSIs should be set across the entire width of a **blended curb's** edge (exclusive of flares) and set back 150 mm to 200 mm from the curb's edge, and they should extend a minimum depth of 610 mm in the direction of travel.

For guidelines on TWSIs and moving walkways, please see Section 5-8, Clearing Our Path.

Guidance TWSI

CNIB recommends guidance TWSIs consist of a guiding pattern constructed of parallel flat-topped elongated bars that extend in the direction of travel.

Guidance TWSIs would be appropriate at the following locations:

- Bus shelters
- Train stations
- Subway platforms
- Airports
- Sports arenas/stadiums
- Large open spaces, such as public squares

When guidance TWSIs are installed, the base surface should be less than 3mm above the surrounding ground or floor surface so they do not create a tripping hazard. TWSIs should always be adhered firmly so there is no likelihood of the edges lifting.

CNIB recommends guidance TWSIs have the following specifications:

- They should be a minimum width of 250mm and a maximum of 550mm.
- They should have a minimum clearance of 600mm on either side of them.
- The height of the bars should be 5mm +/- 1mm.
- The width of the top of the flat-topped elongated bars should be between 17 mm and 30 mm.
- The width of the base of the bars should be 10mm +/- 1mm wider than the top.

- The spacing between adjacent flat-topped bars should be adjusted depending on the size of the bars, as shown in the table below. The larger the individual bars, the farther the space between them:

Width of flat-topped bars (mm)	Spacing between the centre of adjacent bars (mm)
17	72 to 78
20	73 to 80
23	75 to 83
25	80 to 85

When used to cross the path of travel, in locations such as bus shelters, guidance TWSIs should be a minimum width of 550mm to ensure detection.

For more information see, Clearing Our Path at www.cnib.ca.

Exterior Walks

3.8.3.2. Exterior Walks

- 1) Exterior walks that form part of a barrier-free path of travel shall
 - a) have a cross slope of not more than 1:50,
 - b) be not less than 1 100 mm wide,
 - c) have a level area conforming to Clause 3.8.3.4.(1)(c) adjacent to an entrance doorway,
 - d) have a curb not less than 75 mm high wherever there is a vertical drop more than 75 mm from the walk surface and there is no wall, railing, or other barrier to provide protection,
 - e) have a surface not less than 1 100 mm wide of a different texture and contrasting in colour to that surrounding it, if the path of travel is level and even with adjacent surfaces,
 - f) be free from obstructions for the full width of the walk to not less than 1 980 mm, except that handrails are permitted to project not more than 100 mm from either or both sides into the clear area, and
 - g) be designed as a ramp where the slope of the walk is more than 1 in 20.

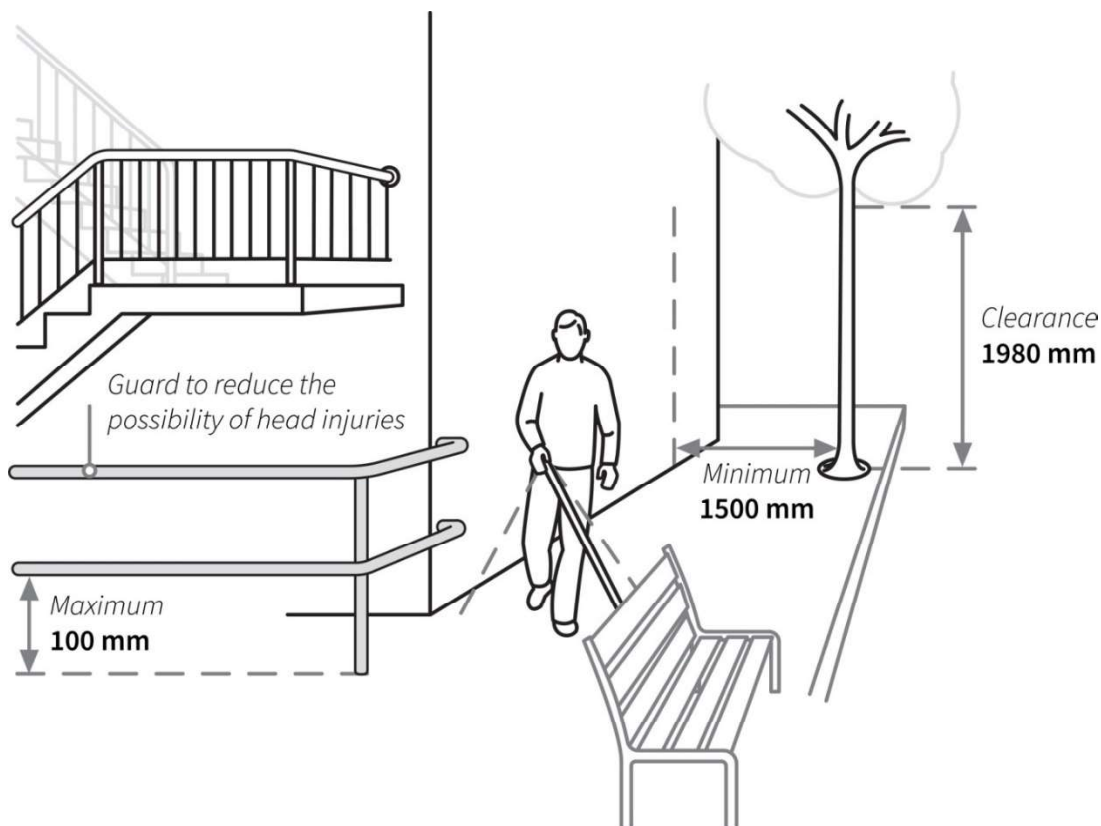

Best Practice

The ABC requires that one exterior walk shall be barrier-free. However, all designated public access routes should be designed to meet the needs of seniors, persons with disabilities and even parents with strollers. The surface of a walkway shall have a hard and even surface that will permit a safe, continuous and uninterrupted barrier-free path of travel.

Uneven surfaces can be hazardous to seniors, people with visual disabilities, people with physical disabilities, and to any ambulant person. Pre-cast units, such as brick pavers, concrete slabs or tiles, should not be used. However, if they are used, care should be taken to ensure that all joints are flush and level. In all cases, the selected material for the surface shall be slip-resistant.

An exterior walk shall be at least 1 100 mm wide. This minimum width requirement allows a person using a wheelchair to pass an ambulatory person with ease. The preferred width that would allow a person using a wheelchair to pass another person in a wheelchair is 1 500 mm.

It is also good practice that every 30 m, the walkway should be widened to 1 500 mm for a length of 2 000 mm to act as a rest area.

Gratings, manhole covers, electrical vaults, and other access covers should be placed adjacent to walkways unless prevented by site constraints. If these covers must be in walkways, the gratings shall have a maximum clear opening of 13 mm (although, due to the ventilation requirements, the gratings on electrical vaults may be larger). The long dimension of the openings shall lie perpendicular to the path of travel.

Joints in sidewalks or between bricks or stones should not exceed 13 mm in width and 6 mm in depth, and shall be flush with the adjoining surfaces.

Any part of a path that has a slope steeper than 1 in 20 in a barrier-free path of travel shall be designed as a ramp. A curb on the ramp helps to prevent the front guide wheels of a wheelchair from accidentally going over the edge where the drop off exceeds 75 mm. A 75 mm curb is also required to help guide a person who has a visual impairment or is blind and may use a cane.

To assist persons with visual disabilities, the surface of the walk should be easily discernible from the surrounding areas. Pathways across parking lots and large plazas can be identified by the use of different textures and contrasting colours. Uneven surfaces are a hazard to people with visual disabilities.

The requirement to have an area free from obstructions is primarily to aid persons with visual impairments and persons who are blind or elderly who may require the use of a mobility aid. Examples of obstructions are directional signs, tree branches, and guy wires. Overhead objects (e.g., signage, tree branches/limbs, free-standing staircases/escalators) should be at a height of 1 980 mm or greater to avoid becoming a hazard.

A level surface shall be maintained behind cross ramps for smooth pedestrian and wheelchair travel.

A level area of at least 1 500 mm by 1 500 mm is to be provided in front of the entrance to allow ease of access into or out of a building.

Ramps

3.8.3.4. Ramps

- 1) A ramp located in a barrier-free path of travel shall
 - a) have a clear width of not less than 870 mm (see A-3.4.3.4. in Appendix A),
 - b) have a slope of not more than 1 in 12, (See Appendix A),
 - c) have a level area not less than 1 500 by 1 500 mm at the top and bottom and at intermediate levels of a ramp leading to a door, so that on the latch side the level area extends not less than
 - i) 600 mm beyond the edge of the door opening where the door opens towards the ramp, or
 - ii) 300 mm beyond the edge of the door opening where the door opens away from the ramp (See Appendix A),
 - d) have a level area not less than 1 200 mm long and at least the same width as the ramp at intervals of not more than 9 m along its length,



SECTION 3

- e) except as permitted by Sentence (2), be equipped with handrails and guards conforming to Articles 3.4.6.5. and 3.4.6.6.,
- f) have a level area not less than 1 200 by 1 200 mm where a ramp makes a 90° turn, and
- g) have a level area not less than 1 500 by 1 500 mm where a ramp makes a 180° turn.

Ramps with a gradient of 1 in 10 or more may be difficult for someone with limited upper-body strength, agility, and/or balance, especially an elderly person who uses a mobility aid like a walker. Even though they pose less of a problem for people using motorized wheelchairs, such ramps can be unsafe to descend for every person, especially if covered by snow and ice. Although Article 3.8.3.4. permits slopes on ramps of 1 in 12 for distances of up to 9 m, gradients of 1 in 20 are safer and less strenuous for the user.

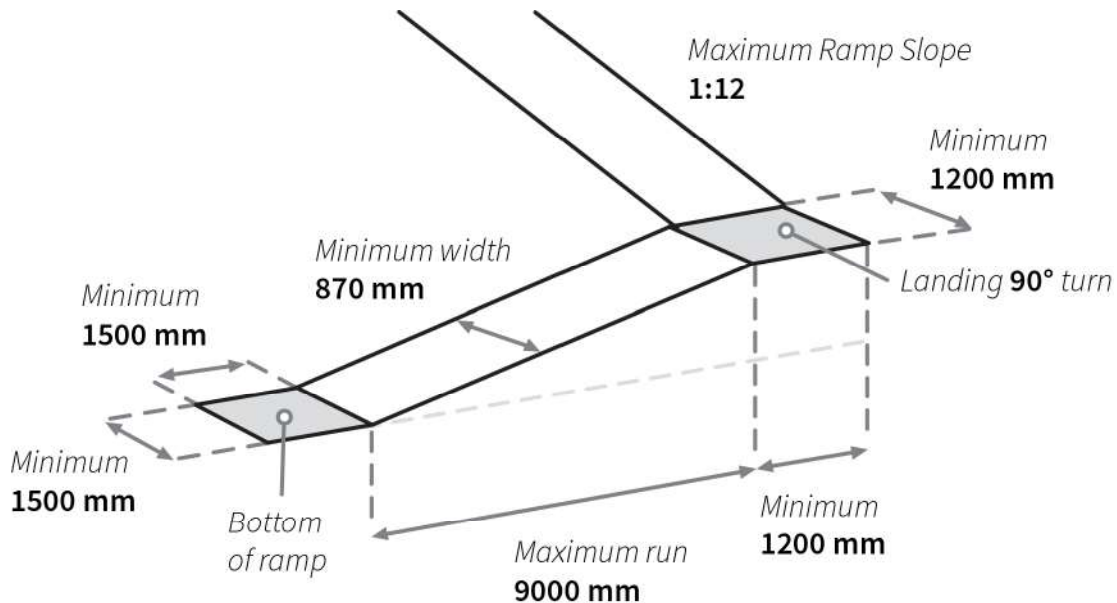
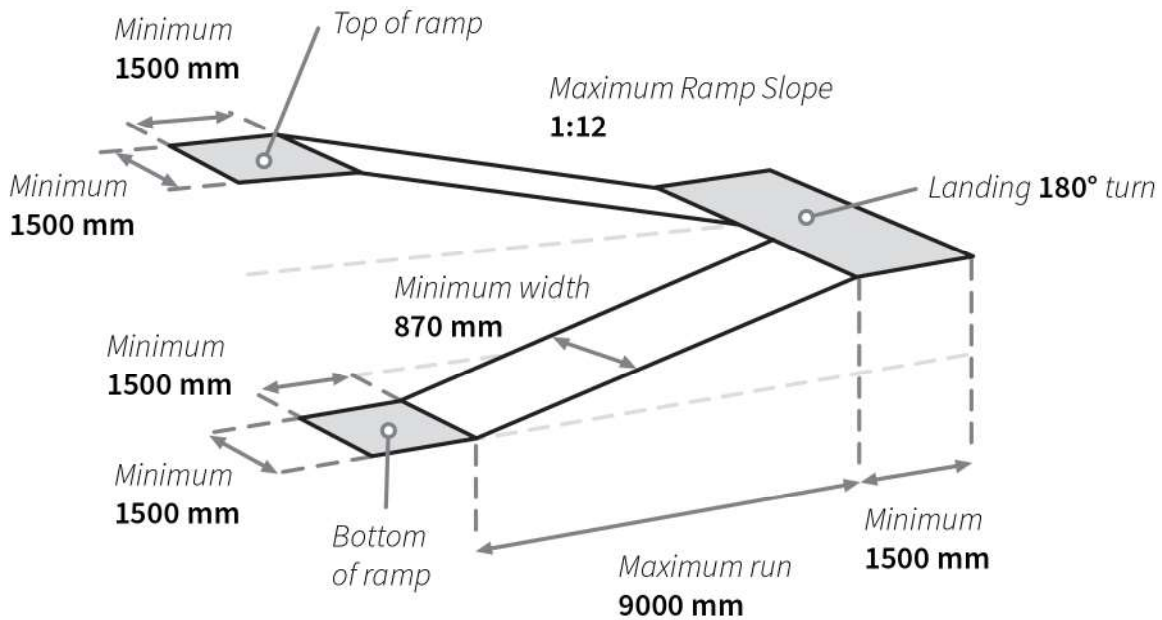

Tactile warning strips should be used for the full width of the stairs and laid up to be 600 mm in depth approaching the stair. A 15 mm-wide strip that is contrasting in colour and texture shall be used at the top of ramps or stairs to warn users of a change in elevation. Ramps in a barrier-free path of travel shall have a minimum unobstructed width of 870 mm and a maximum slope of 1 in 12.

A level landing of at least 1 500 mm by 1 500 mm is required at the top and bottom of the ramp. Intermediate landings shall be provided at intervals of not more than 9 m. This allows an opportunity for a person to stop and rest if necessary. These landings should be at least the width of the ramp and 1 200 mm in length.

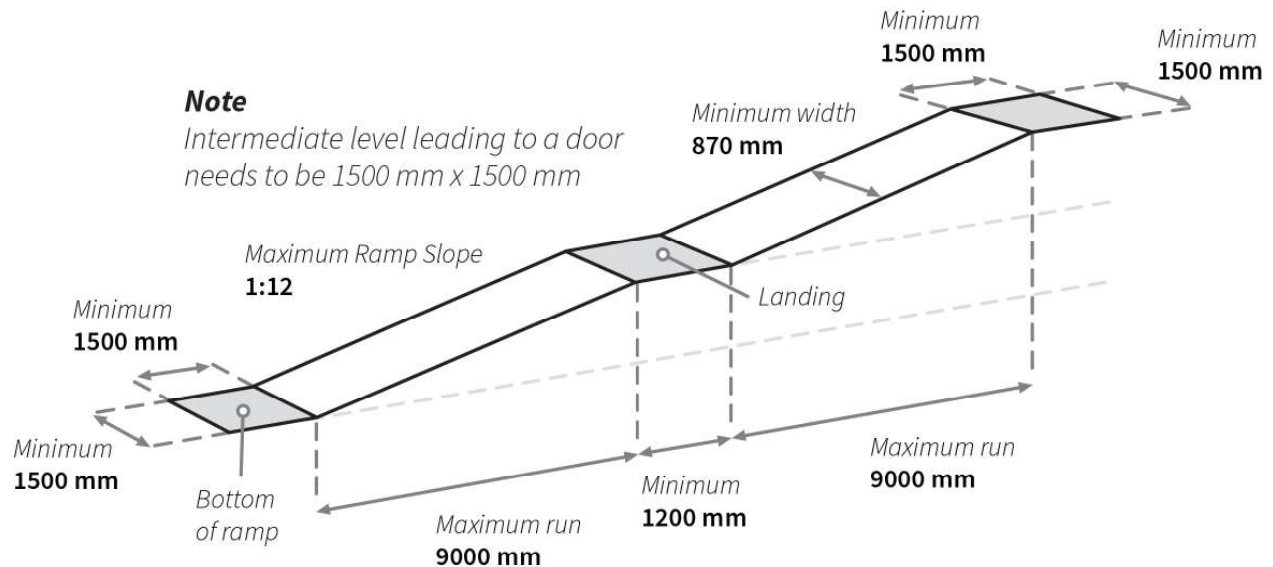

3.8.1.3. Barrier-Free Path of Travel

- 4) The width of a barrier-free path of travel that is more than 30 m long shall be increased to not less than 1 500 mm for a length of 1 500 mm at intervals not exceeding 30 m.

Where ramps are used and are not part of a barrier-free path of travel, the maximum gradient may exceed 1 in 12; however, it is dependent on the type of occupancy involved. (See Article 3.4.6.7.) Where alternate routes are provided for persons with disabilities, signs are required to give directions.

3.4.6.7. Ramp Slope

(See also Article 3.8.3.4.)

- 1) Except as required for aisles in Article 3.3.2.5., the maximum slope of a ramp shall be
 - a) 1 in 10 in any assembly, care, treatment, detention or residential occupancy,
 - b) 1 in 6 in rooms or floor areas classified as a mercantile or industrial occupancy,,
 - c) 1 in 8 in any other floor area, and
 - d) 1 in 10 for an exterior ramp.

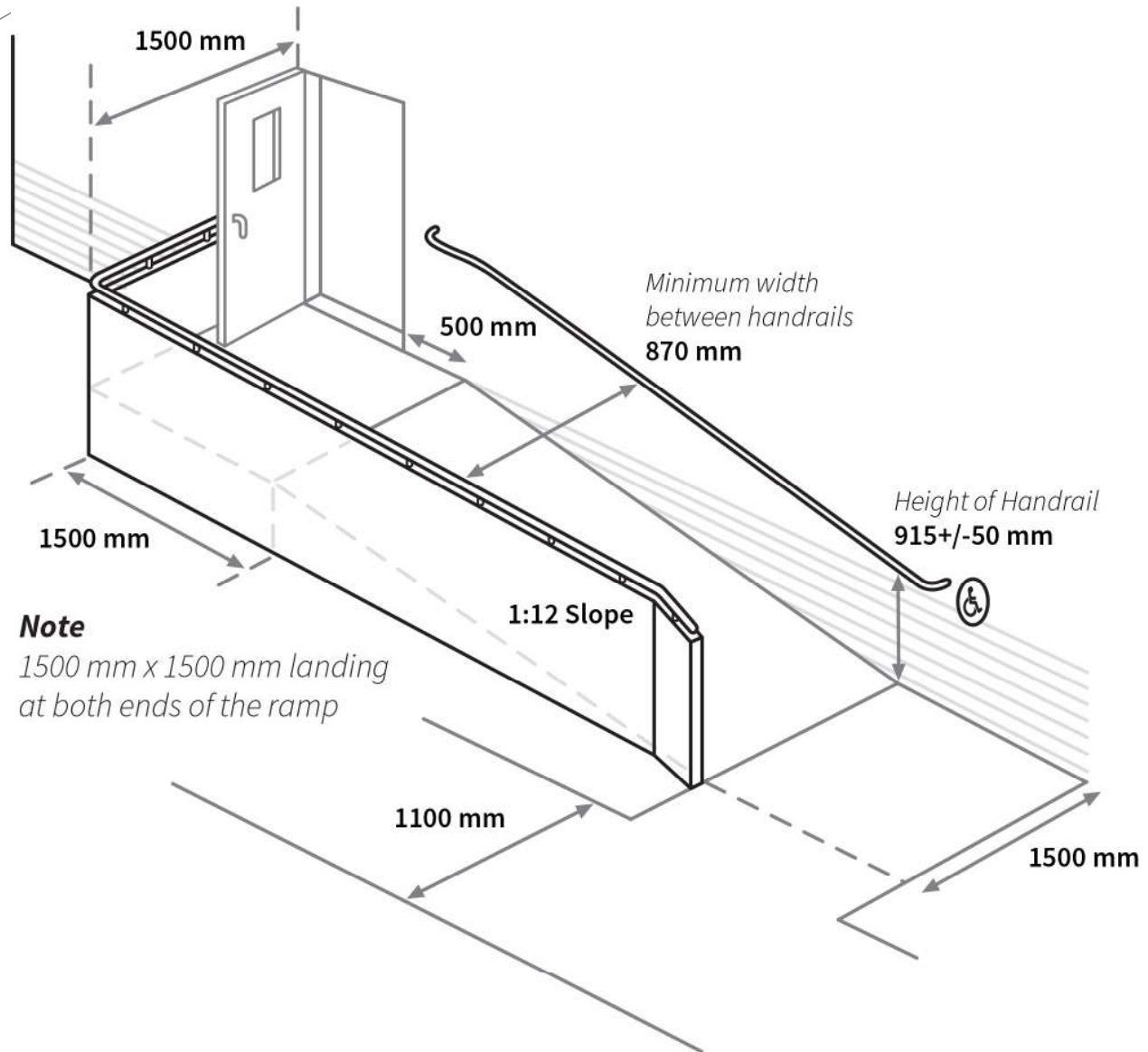

Protection at Sides of Ramps

A variety of provisions can be used to prevent people using wheelchairs or other mobility aids from accidentally going over the edge of a ramp. Curbs are often combined with handrails and guards.

3.8.3.4. Ramps

- 2) The requirement for handrails in Clause (1)(e) need not apply to a ramp serving as an aisle for fixed seating.
- 3) Floors or walks in a barrier-free path of travel having a slope steeper than 1 in 20 shall be designed as ramps.

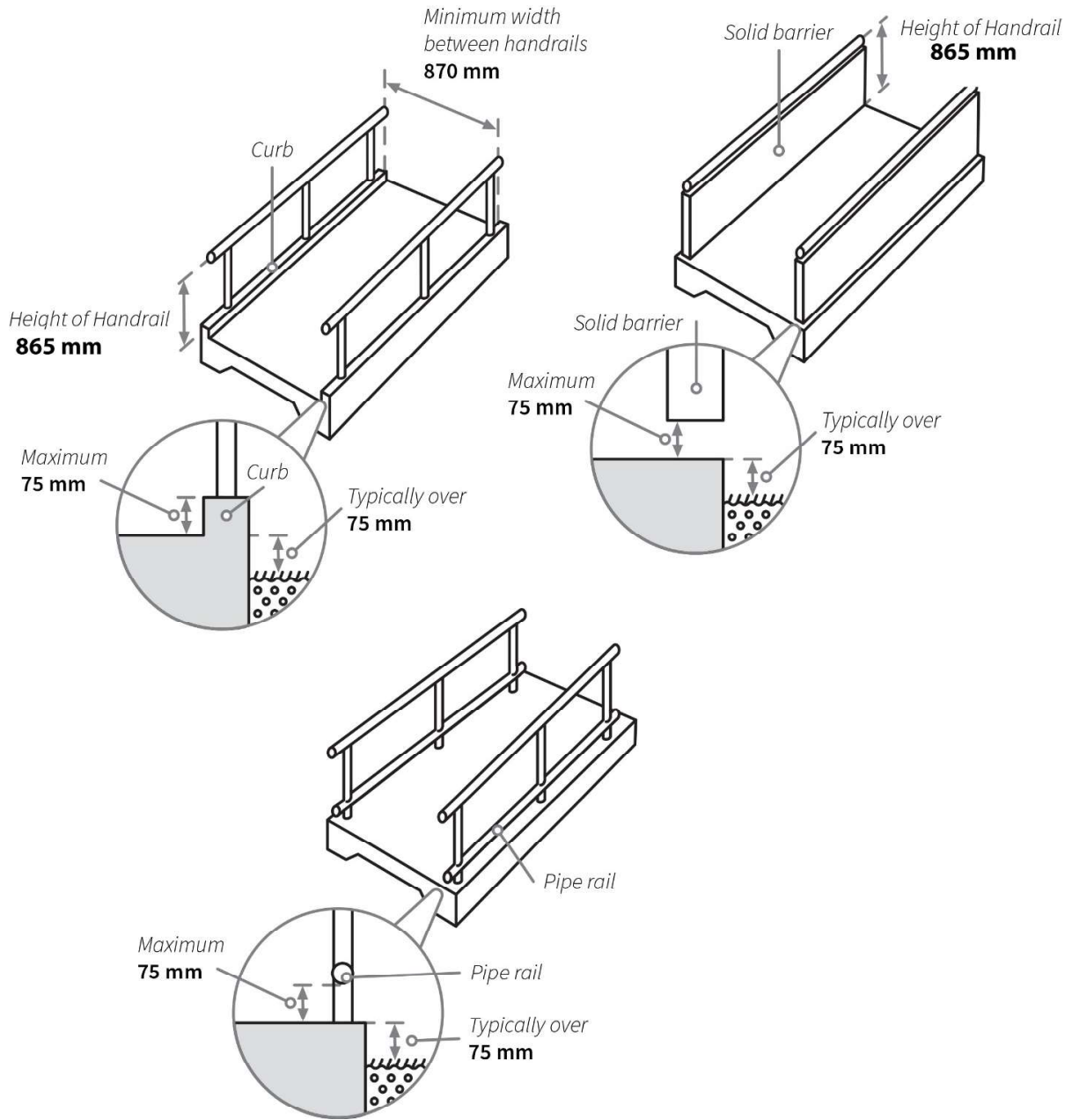

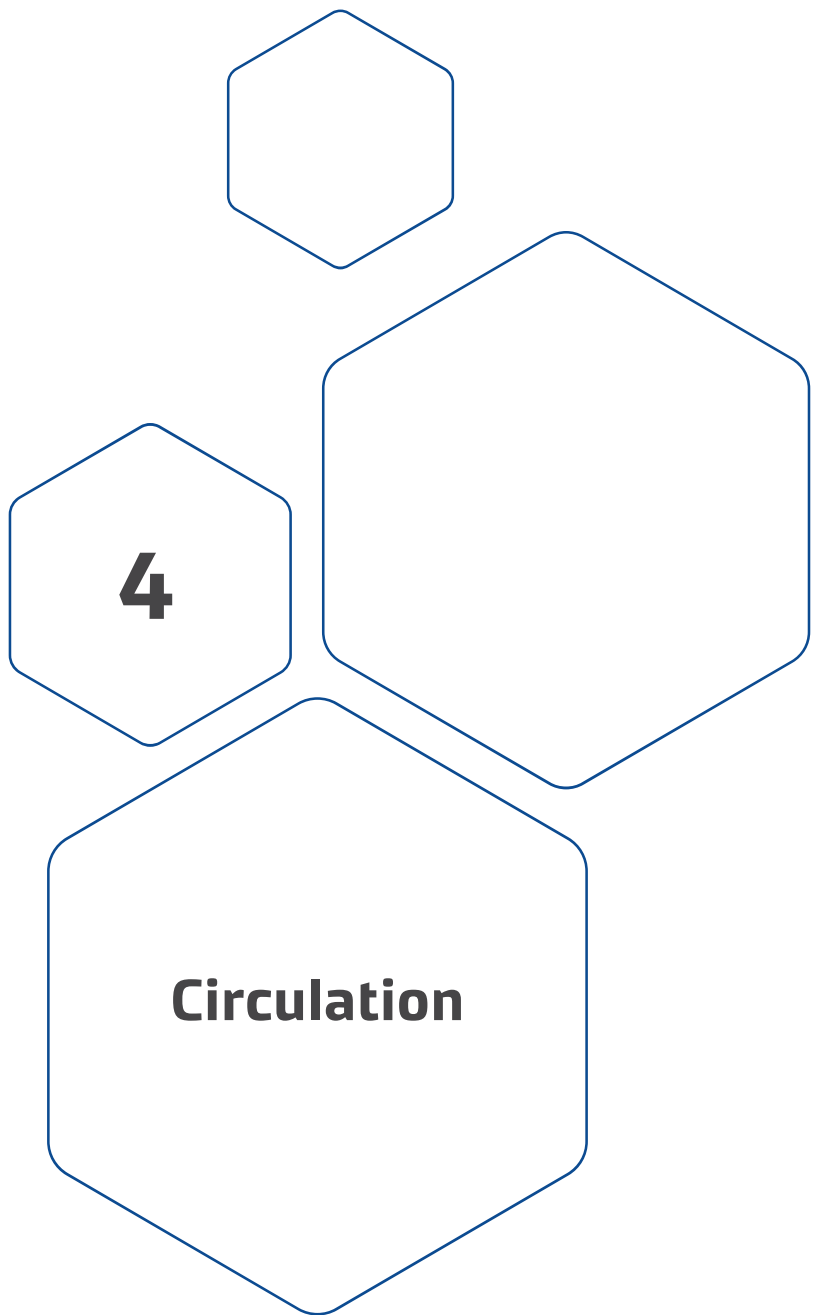

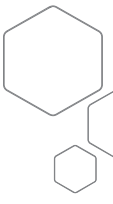

Circulation

Wayfinding

Wayfinding is integral to orientation and often key in the safe and effective mobility of many populations; in particular, people with visual disabilities. Wayfinding design organizes the built environment to provide useful information for navigation by ensuring there is the opportunity to use cognitive and perceptual information to arrive independently at the desired destination.

There are four basic wayfinding information types: orientation, direction, identification, and general information. There are four primary senses that are used in building information: visual, auditory, tactual, and olfactory. People who have visual disabilities may use any combination of these design elements in wayfinding.

- Logical and intuitive space
- Textural contrasts and tactile cues
- Acoustics
- Colour and brightness contrast
- Signage, including tactile, Braille, and audible signs
- Appropriate, well-designed lighting

This becomes even more important in the event evacuation becomes necessary; it is recommended that all buildings have well-planned and well-marked evacuation routes. Wayfinding can have a dramatic effect for any building user.

For more information on wayfinding or designing for vision loss, see www.cnib.ca.

Circulation

There should be wayfinding design and unobstructed movement within a building, its facilities, and other spaces, including its exterior property, such as pedestrian pathways and parking lots.

Accessible Entrances

3.8.1.2. Entrances

- 1) In addition to the barrier-free entrances required by Sentence (2), not less than 50% of the pedestrian entrances, including the primary entrance, of a building referred to in Sentence 3.8.1.1.(1), including walkways leading to the entrances from a public thoroughfare and from on-site parking areas, shall be barrier-free.

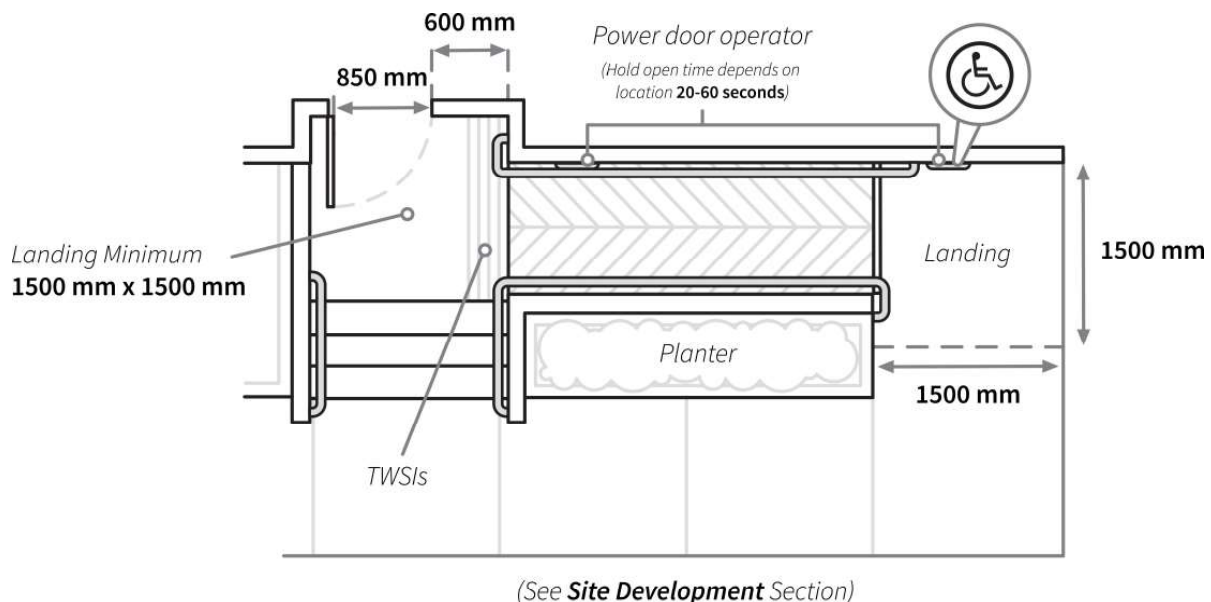
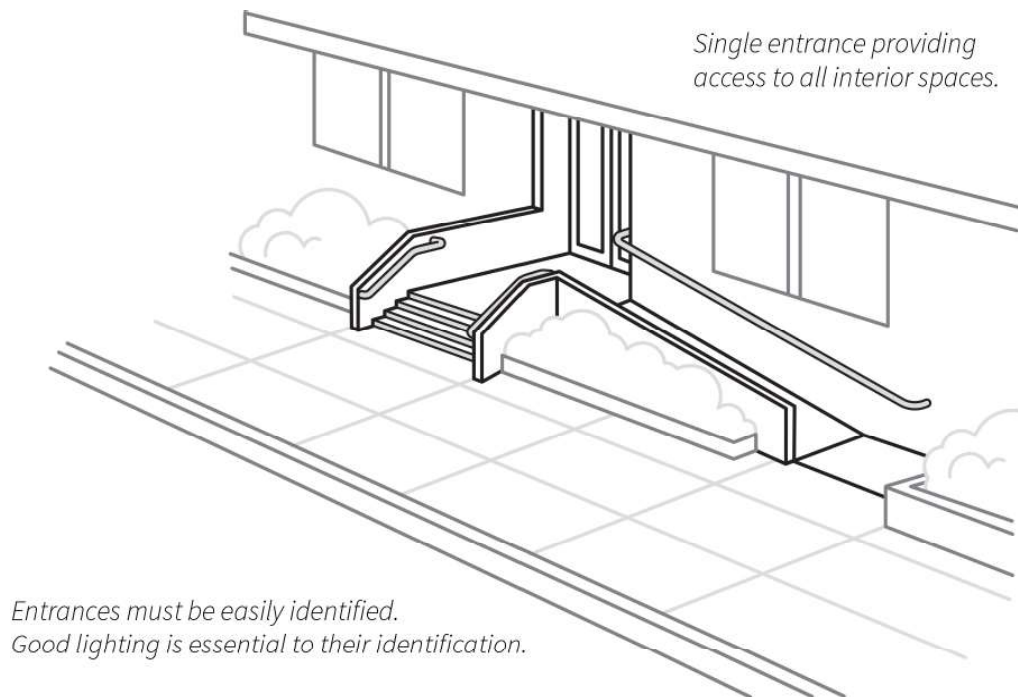

The primary entrance of the building shall be designed to be barrier-free. The remaining 50% (at least) of the total number of entrances in the building shall also be barrier-free. This provides alternate egress routes in case of an emergency. The requirements for an acceptable barrier-free doorway are found in Article 3.8.3.3. Should there be a ramp that leads to the accessible entrance; the requirements are to be found in Article 3.8.3.4.

Clear and sufficient signage is required to indicate the way to and location of all doors designated for use by people with physical disabilities or mobility issues.

**Note**

The entrance is also part of a barrier-free path of travel; thus, power-operated doors may be required.

**Best Practice**

All building entrances should be barrier-free to ensure maximum egress for all occupants in an emergency.

- 2) A suite of assembly occupancy, business and personal-services occupancy or mercantile occupancy that is located in the first storey of a building, or in a storey to which a barrier-free path of travel is provided, and that is completely separated from the remainder of the building so that there is no access to the remainder of the building, shall have at least one barrier-free entrance.

Some buildings are divided into areas that are not interconnected on the inside. Individual barrier-free entrances shall then be provided to these facilities from the outside. For example, a strip shopping centre can have a number of shops, offices, or restaurants that are only accessible from the outside. The entrances to all these facilities shall be barrier-free in order to minimize or eliminate obstacles that would require assistance to accessing necessary services and social or recreational opportunities.

- 3) A barrier-free entrance required by Sentences (1) or (2) shall be designed in accordance with Article 3.8.3.3.
- 4) At a barrier-free entrance that includes more than one doorway, only the primary entrance shall be required to be designed in accordance with the requirements of Article 3.8.3.3.

**Best Practice**

Even though the primary entrance is required to be barrier-free, it is recommended that a second doorway — on (a) different side(s) of the building — be made accessible in case the primary entrance becomes impassable, especially in an emergency; when egress is important. (Adjacent doors in a bank of doors are considered to be a single entrance.)

- 5) If a walkway or pedestrian bridge connects two barrier-free storeys in different buildings, the path of travel from one storey to the other storey by means of the walkway or bridge shall be barrier-free.
- 6) If an entrance is equipped with a security system, both visual and audible signals shall be used to indicate when the door lock is released.

Doorways

It is necessary that every doorway in a barrier-free path of travel shall have a clear opening width of a minimum of 850 mm when the door is in a fully opened position (i.e., 90°) to allow a larger wheelchair or scooter access in and out of the space. The door shall also be easy to open manually with a force of 22N for interior doors and 38N for exterior doors to ensure that all people, including people with limited physical strength, have unrestricted access—entry to AND egress from a space. Additionally, the doorway shall provide a minimum of 600 mm of clear space on the latch side of the door to allow a person in a wheelchair, or those using other mobility aids, ease of movement and safety. Power-assist doors shall be used if either or both the required force and a clear space is not achievable.

3.8.3.3. Doorways and Doors

- 1) Every doorway that is located in a barrier-free path of travel shall have a clear width not less than 850 mm when the door is in the open position. (See Appendix A.)

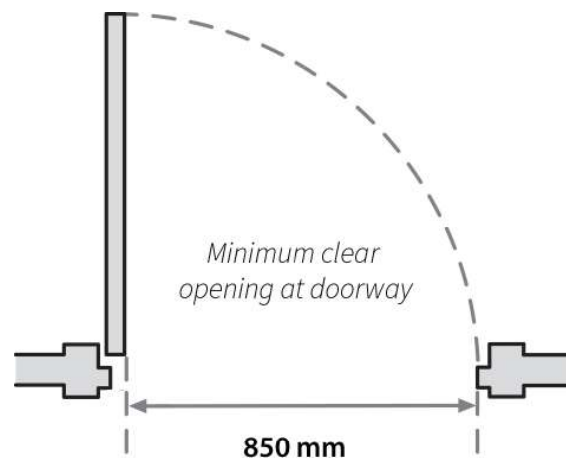

- 2) Every doorway into rooms within a suite of residential occupancy shall have a clear width not less than 850 mm when the door is in the open position. (See Appendix A.)
- 3) Door operating devices shall be of a design which does not require tight grasping and twisting of the wrist as the only means of operation. (See Appendix A.)

Lever handles are preferred by people with limited strength or limited ability to grasp with their hands and/or to turn their wrists/arms. Knob-type handles are difficult to manipulate. Lever handles with the ends turned toward the door are less of a hazard than are other handle designs with sharp or abrupt edges, because people with visual disabilities often trail wall or door surfaces with their hands.



Best Practice

Door hardware should be installed between 900 mm and 1 065 mm above the finished floor.

Note

The doorway width of 850 mm does not factor in the lever handle or push bar hardware because these are located between 900 mm and 1 100 mm above the finished floor and do not interfere with movement through the doorway. If the lever handle or push bar is located below 850 mm, the clear opening width shall be measured from the hardware on the door rather than the door itself.

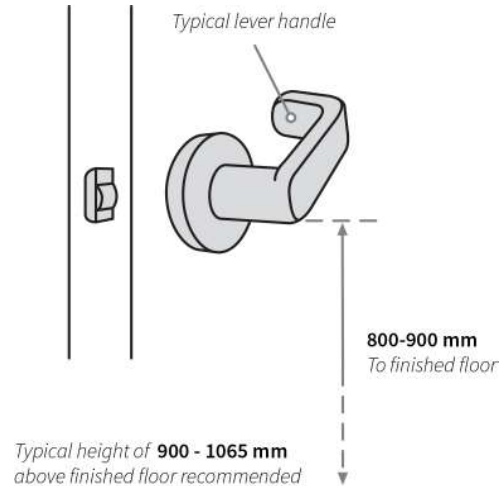

- 4) A threshold for a doorway, as referred to in Sentences (1) or (2), shall be not more than 13 mm higher than the finished floor surface and shall be bevelled to facilitate the passage of wheelchairs.

Best Practice

It is preferred that raised thresholds in doorways be avoided. However, where they are necessary or unavoidable, they shall not exceed 13 mm in height above the finished floor surface. If the threshold is no greater than 13 mm, it shall be bevelled to provide smooth transition from area to area. Also, the threshold should be identified by an alternate colour or brightness to indicate a change in level from area to area. This may prevent people who use mobility aids (such as walkers), people with visual disabilities and seniors from tripping.

- 5) Except as provided in Sentences (6) and (12), every door that provides a barrier-free path of travel through an entrance referred to in Article 3.8.1.2., including the interior doors of a vestibule where provided, shall be equipped with a power door operator that allows persons to activate the opening of the door from either side if the entrance serves
- a hotel,
 - a building of Group B, Division 2 major occupancy, or
 - a building of Group A, Group B, Division 3, Group D or E major occupancy more than 500 m² in building area. (See Appendix A.)
- 6) The requirements of Sentence (5) do not apply to an individual suite having an area less than 500 m² in a building having only suites of assembly, care, business and personal services or mercantile occupancy, if the suite is completely separated from the remainder of the building so that there is no access to the remainder of the building.

- 7) Except as permitted by Sentence (8) and except for a door with a power door operator, a closer for a door in a barrier-free path of travel shall be designed to permit the door to open when the force applied to the handle, push plate or latch-releasing device is not more than
- 38 N in the case of an exterior door, or
 - 22 N in the case of an interior door.

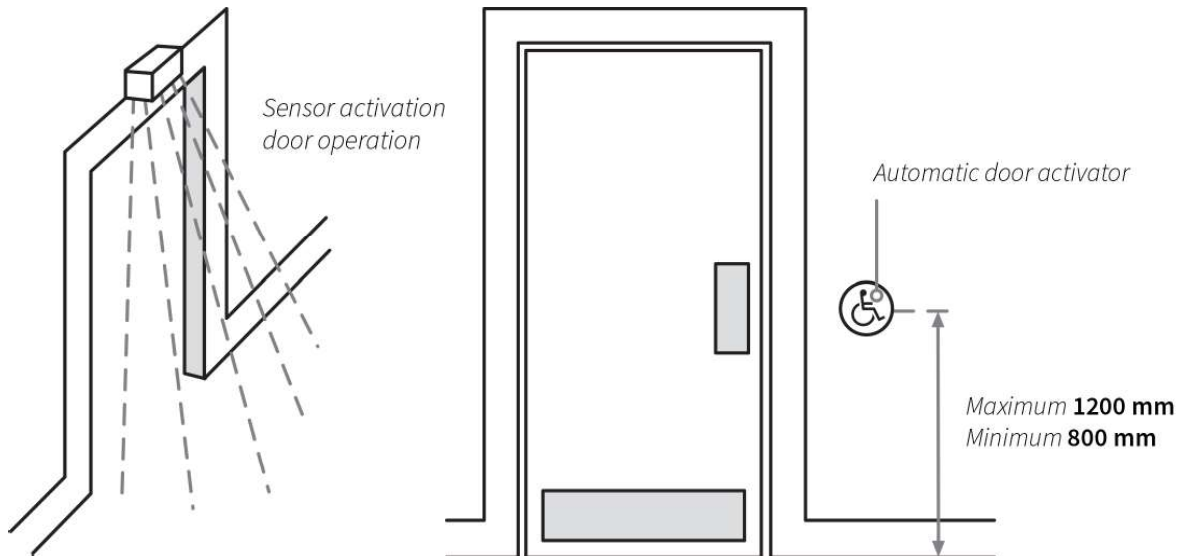

A power-operated door is required to be installed at entrances of buildings where the public is expected to assemble, in a care facility that any number of persons may need assistance, or in any building of major occupancy 500 m² or greater.

Door closers shall permit the opening of an exterior door with a maximum force of 38 N and for an interior door a maximum force of 22 N (2.3 kg/5 lb push/pull) or less. The exception is doors to dwelling units.

- 8) Sentence (7) does not apply to a door at the entrance to a dwelling unit, or where greater forces are required in order to close and latch the door against the prevailing difference in air pressure on opposite sides of the door. (See Appendix A.)
- 9) Except for a door at the entrance to a dwelling unit, a closer for an interior door in a barrier-free path of travel shall have a closing period of not less than 3 s measured from when the door is in an open position of 70° to the doorway, to when the door reaches a point 75 mm from the closed position, measured from the leading edge of the latch side of the door. (See Appendix A.)
- 10) Unless equipped with a power door operator or within a suite, a door in a barrier-free path of travel shall have a clear space on the latch side extending the height of the doorway and not less than
- 600 mm beyond the edge of the door opening if the door swings toward the approach side, and
 - 300 mm beyond the edge of the door opening if the door swings away from the approach side. (See Appendix A.)

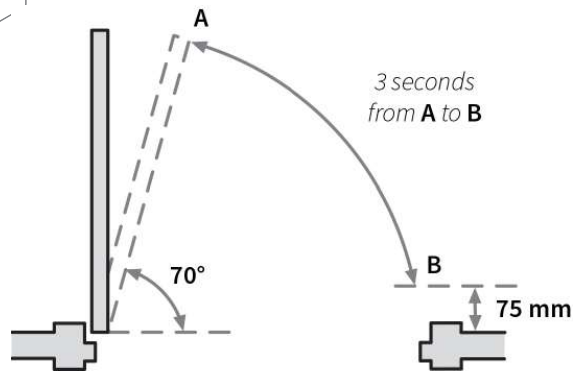

Best Practice

Power-door operators should be located on a wall or post 1.5 m minimum distance back from the door if it swings outward on approach to the entry so it may not impede the mobility or safety of a person using a wheelchair or other mobility device.

If the door swings inward, the opener should be placed a minimum of 900 mm on approach. The minimum distance also applies to surface and motion sensors.

The push button operators for the power-assisted door should be mounted 900 mm – 1 100 mm high for ease of access and use. The doors and operators will be identified by visible signage with the international symbol for accessibility.

Even though the ABC states that 3 seconds is sufficient, the preference is that closers will have a set delay of 8-10 seconds before they begin to close. This is to ensure that persons who use wheelchairs or other mobility devices and seniors may pass through the doorway safely. Where such doors exist related to vestibules, both the exterior and interior doors of a vestibule should be power operated, as a person relying upon one set of doors to be power operated will also rely upon the second set to be power operated.

In cases where security is required, the doors may be activated by a key card or remote. The devices shall be installed on an adjacent wall or a floor-mounted post at a minimum 1 200 mm back from the door in order to allow proper access. In the event of a power failure, power-operated doors shall be manually operable.

- 11) A vestibule located in a barrier-free path of travel shall be arranged to allow the movement of wheelchairs between doors, and shall provide a distance between 2 doors in series of not less than 1 200 mm plus the width of any door that swings into the space in the path of travel from one door to another.
- 12) Only the active leaf in a multiple leaf door in a barrier-free path of travel need conform to the requirements of this Article.

Best Practice

Even though 3.8.3.3.(11) requires the distance between 2 doors in a vestibule or series to be no less than 1 200 mm. It is preferable that each set of doors in a series have at least a 1 600 mm clearance to prevent a person in a wheelchair or scooter from becoming trapped within the vestibule.

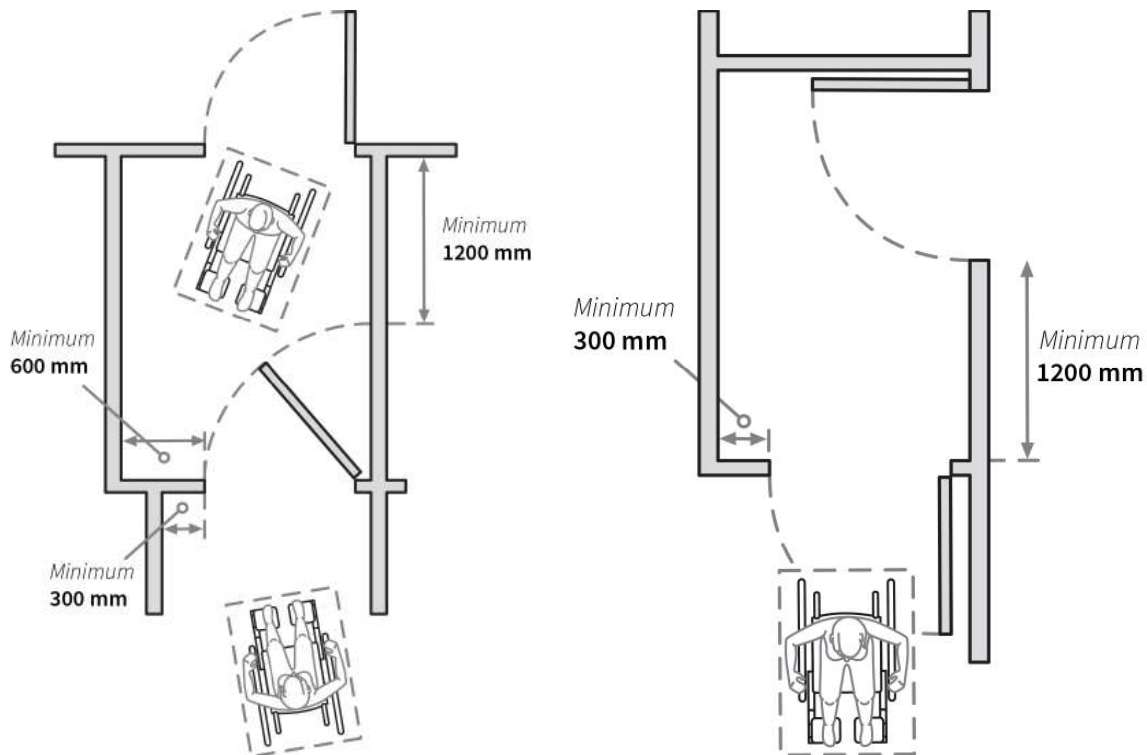

Entrances shall be identified by the use of contrasting colours for door frames, handles, awnings, etc. Entrances and vestibules should be well lit. Additionally, entrances from the exterior of the building and related vestibules should be illuminated with evenly distributed and high levels of lighting.

- 13) Except as provided in Clause 3.8.3.4.(1)(c), the floor surface on each side of a door in a barrier-free path of travel shall be level within a rectangular area
 - a) as wide as the door plus the clearance required on the latch side by Sentence 3.8.3.3.(10), and
 - b) whose dimension perpendicular to the closed door is not less than the width of the barrier-free path of travel but need not exceed 1 500 mm.

Corridors

3.3.1.9. Corridors

- 1) The minimum width of a public corridor shall be 1 100 mm.
- 2) Except as required by Sentence 3.3.3.3.(3), the minimum unobstructed width of a corridor used by the public or a corridor serving classrooms or patients' sleeping rooms shall be 1 100 mm.
- 3) Except as permitted by Sentence (4), obstructions located within 1 980 mm of the floor shall not project more than 100 mm horizontally into an exit passageway, a public corridor, a corridor used by the public or a corridor serving classrooms or patients' sleeping rooms, in a manner that would create a hazard for a person with a visual disability travelling adjacent to the walls.

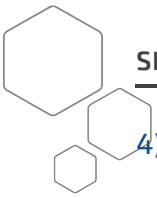

SECTION 4

- 4) The horizontal projection of an obstruction referred to in Sentence (3) is permitted to be more than 100 mm provided the clearance between the obstruction and the floor is less than 680 mm. (See Appendix A.)
- 5) If a corridor contains an occupancy, the occupancy shall not reduce the unobstructed width of the corridor to less than its required width.
- 6) If a public corridor conforming to Clause 3.4.2.5.(1)(d) contains an occupancy,
 - a) the occupancy shall be located so that for pedestrian travel there is an unobstructed width not less than 3 m at all times adjacent and parallel to all rooms and suites that front onto the public corridor, and
 - b) the combined area of all occupancies in the public corridor shall be not more than 15% of the area of the public corridor.
- 7) Except for a dead end corridor that is entirely within a suite or as permitted by Sentences 3.3.3.3.(1) and 3.3.4.4.(6), a dead-end corridor is permitted provided it is not more than 3 m long.

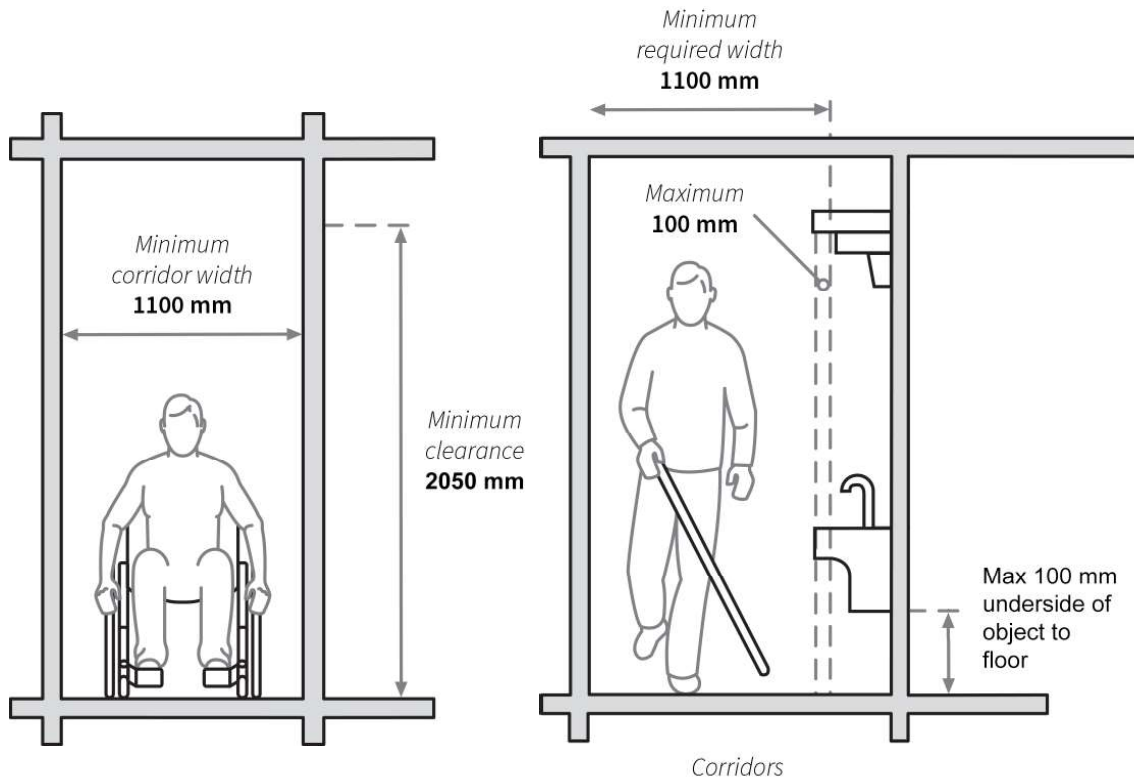

The sweep of a cane used by people with visual disabilities normally detects obstructions that are within 680 mm of the floor. Any obstruction above this height would not be detected with a cane and could create a hazard when the object (e.g., a water fountain, a fire extinguisher, a wall-mounted telephone, a bench, a wall-mounted waste receptacle) projects more than 100 mm into the path of travel.

Overhead Hazard

3.3.1.8. Headroom Clearance

- 1) Except within the floor area of a storage garage, the minimum headroom clearance in every access to exit shall conform to the requirements of Article 3.4.3.4. for exits. (See also Sentence 3.3.5.4.(5).)



Best Practice

If the overhead clearance is reduced, or open areas under hanging stair landings and escalators exist, then a cane-detectable barrier (e.g., planters, fencing, benches, railings) extending within the entire associated floor area should be used for safety reasons. It is preferred that the open areas beneath hanging stair landings and escalators be enclosed.

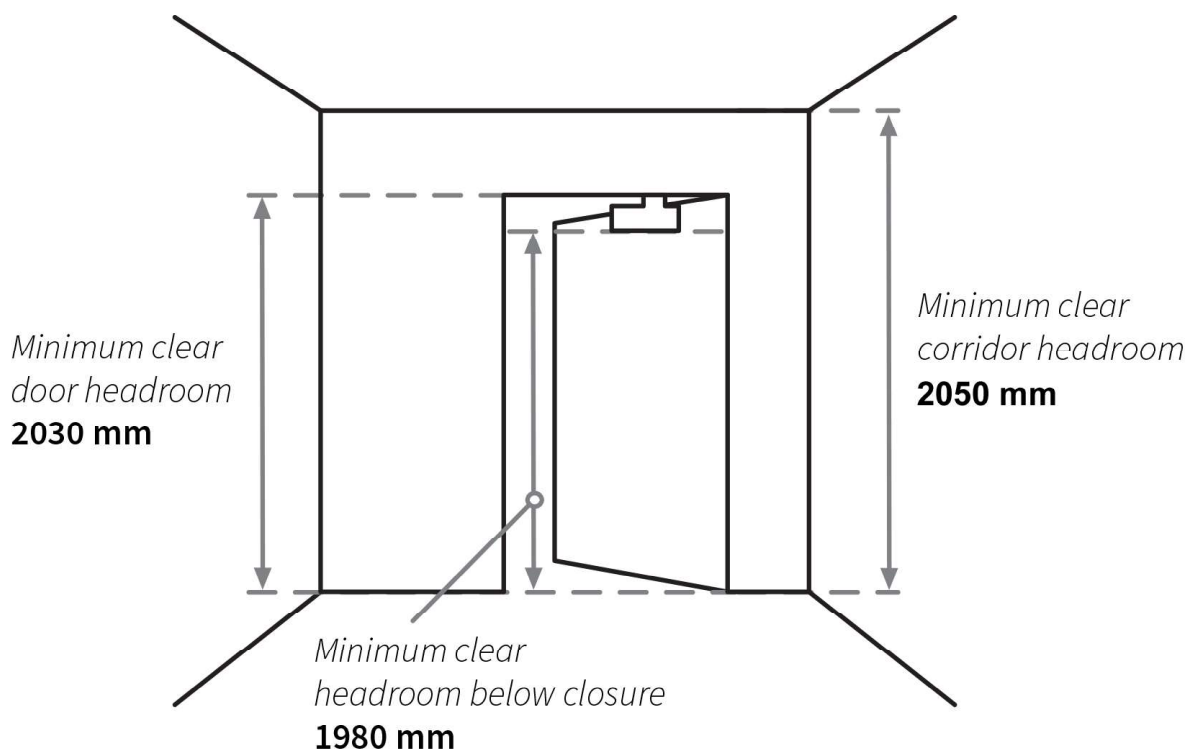

3.4.3.4. Headroom Clearance

(See Appendix A.)

- 1) Except as permitted by Sentences (4) and (5), every exit shall have a clear height over the clear width of the exit of not less than 2 050 mm.
- 2) The clear height of stairways shall be measured vertically over the clear width of the stairway, from the straight line tangent to the tread and landing nosings to the lowest element above. (See A-9.8.7.4. in Appendix A.)

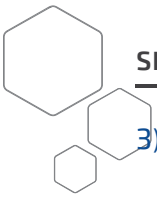

SECTION 4

- 3) The clear height of landings shall be measured within the clear width of the landing vertically to the lowest element above.
- 4) Except as permitted by Sentence (5), the headroom clearance for doorways shall be not less than 2 030 mm.
- 5) No door closer or other device shall be installed so as to reduce the headroom clearance of a doorway to less than 1 980 mm.

Stairs, Handrails, and Guards

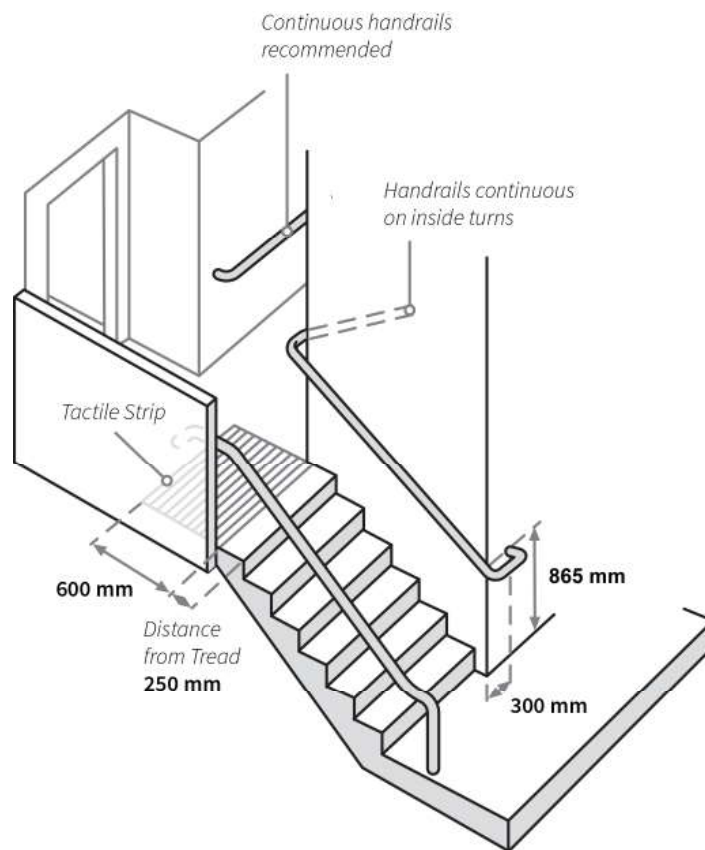

Stairs

3.4.6.1. Slip Resistance of Ramps and Stairs

- 1) The surfaces of ramps, and landings and treads
 - a) shall have a finish that is slip resistant, and
 - b) if accessible to the public, shall have either a colour contrast or a distinctive pattern to demarcate the leading edge of the tread and the leading edge of the landing, as well as the beginning and the end of a ramp.
- 2) Treads and landings of exterior exit stairs more than 10 m high shall be designed to be free of ice and snow accumulations.

Avoid treads that are not raked or have open treads

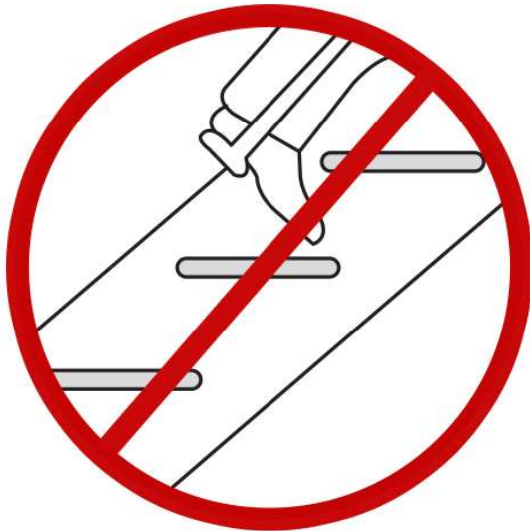

No raked treads

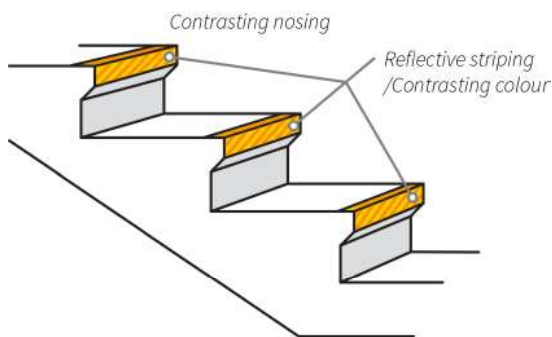

Slipping usually occurs when a person travels from a higher slip-resistant surface to a lower slip-resistant surface (e.g., from cement to marble). Travelling from a rainy outdoor environment to indoor flooring can also cause slipping. Tripping hazards can also occur when a person goes from marble to carpet.



Best Practice

Even though the Code says that colour contrasting or textured pattern can be used to demarcate the treads, it is recommended that colour contrasting or both colour contrasting and a textured nosing be applied for effective demarcation of the risers.

3.4.6.2. Minimum Number of Risers

- 1) Except as permitted by Sentence 3.3.2.14.(1), every flight of interior stairs shall have not less than 3 risers.

In a path of travel from one area to another, designs that include stairs with fewer than three risers shall be avoided. With only one or two risers, the perception of a change in elevation is difficult. Three risers make a more definite statement.

Restaurants that use elevated areas to define spaces shall provide properly designed barrier-free ramps to these areas or provide equally interesting spaces on the entrance level for those using wheelchairs.

3.4.6.8. Treads and Risers

(See A-9.8.4. in Appendix A.)

- 1) Except as permitted for dwelling units and by Sentence 3.4.7.5.(1) for fire escapes, steps for stairs shall have a run of not less than 280 mm between successive steps.
- 2) Steps for stairs referred to in Sentence (1) shall have a rise between successive treads not less than 125 mm and not more than 180 mm.
- 3) Except in fire escape stairs and where an exterior stair adjoins a walkway as permitted in Sentence 3.4.6.3.(3), risers, measured as the vertical nosing-to-nosing distance, shall be of uniform height in any one flight, with a maximum tolerance of
 - a) 5 mm between adjacent treads or landings, and
 - b) 10 mm between the tallest and shortest risers in a flight.

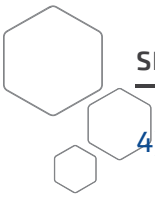

SECTION 4

- 4) Except in fire escape stairs, treads, measured as the horizontal nosing-to-nosing distance, shall have a uniform run with a maximum tolerance of
 - a) 5 mm between adjacent treads, and
 - b) 10 mm between the deepest and shallowest treads in a flight.
- 5) Treads and risers shall not differ significantly in run and rise in successive flights in any stair system.
- 6) Where angled treads are incorporated into a stair, the treads in all sets of angled treads within a flight shall turn in the same direction.
- 7) The slope of treads or landings shall not exceed 1 in 50.
- 8) Except as permitted by Sentence (10), the top of the nosing of stair treads shall have a rounded or bevelled edge extending not less than 6 mm and not more than 13 mm measured horizontally from the front of the nosing.
- 9) The front edge of stair treads in exits and public access to exits shall be at right angles to the direction of exit travel.
- 10) If resilient material is used to cover the nosing of a stair tread, the minimum rounded or bevelled edge required by Sentence (8) is permitted to be reduced to 3 mm.

Nosings on stairs should be of a contrasting colour or colour tone from the respective risers and treads, and should be distinguishable whether approaching the stairs from the top or bottom.

Handrails

3.4.6.5. Handrails

- 1) A stairway shall have a handrail on at least one side, but if it is 1 100 mm or more wide, it shall have handrails on both sides.
- 2) If the required width of a ramp or flight of stairs is more than 2 200mm, one or more intermediate handrails continuous between landings shall be provided, and located so that there will be not more than 1 650 mm between handrails.
- 3) Handrails shall be continuously graspable along their entire length and shall have
 - a) a circular cross-section with an outside diameter not less than 30 mm and not more than 43 mm, or
 - b) a non-circular cross-section with a graspable portion that has a perimeter not less than 100 mm and not more than 125 mm and whose largest cross-sectional dimension is not more than 45 mm.
- 4) The height of handrails on stairs and ramps shall be measured vertically from the top of the handrail to
 - a) a straight line drawn tangent to the tread nosings of the stair served by the handrail (see A-9.8.7.4. in Appendix A), or
 - b) the surface of the ramp, floor or landing served by the handrail.

- 5) Except as provided in Sentences (6) and (7), the height of handrails on stairs and ramps shall be
 - a) not less than 865 mm, and
 - b) not more than 965 mm.
- 6) Handrails installed in addition to required handrails need not comply with Sentence (5).
- 7) Where guards are required, handrails on landings shall be not more than 1 070 mm in height.
- 8) Except where interrupted by doorways or newels at changes in direction, at least one handrail shall be continuous throughout the length of a stairway or ramp, including landings. (See Appendix A.)
- 9) Handrails shall be terminated in a manner which will not obstruct pedestrian travel or create a hazard. (See A-3.4.6.5.(8) in Appendix A.)
- 10) At least one handrail at the side of a stairway or ramp shall extend horizontally not less than 300 mm beyond the top and bottom of the stairway or ramp. (See A-3.4.6.5.(8) in Appendix A.)
- 11) The clearance between a handrail and any surface behind it shall be not less than
 - a) 50 mm, or
 - b) 60 mm if the surface behind the handrail is rough or abrasive.

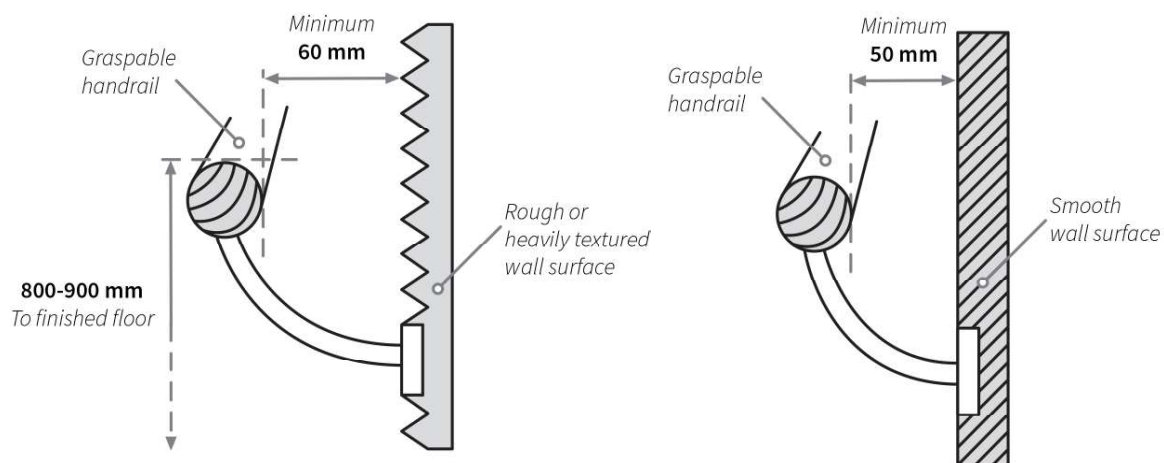

- 12) Handrails and their supports shall be designed and constructed to withstand the loading values obtained from the non-concurrent application of
 - a) a concentrated load not less than 0.9 kN applied at any point and in any direction for all handrails, and
 - b) a uniform load not less than 0.7 kN/m applied in any direction to handrails not located within dwelling units.
- 13) A ramp shall have handrails on both sides.

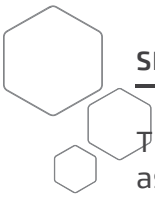

The concept of a graspable handrail is very important because its purpose is to provide assistance, stability, and safety, or act as a guide to the elderly, people with visual disabilities, people with physical disabilities or people who are a little unsteady, tired, or injured. The handrail should be circular and the diameter of the cross-section shall be 30 mm-43 mm to ensure that most hands can wrap around the railing snugly.

9.8.7.4. Height of Handrails

(See Appendix A.)

- 1) The height of handrails on stairs and ramps shall be measured vertically from the top of the handrail to
 - a) a straight line drawn tangent to the tread nosings of the stair served by the handrail, or
 - b) the surface of the ramp, floor or landing served by the handrail.
- 2) Except as provided in Sentences (3) and (4), the height of handrails on stairs and ramps shall be
 - a) not less than 865 mm, and
 - b) not more than 965 mm.
- 3) Where guards are required, handrails required on landings shall be not more than 1 070 mm in height.
- 4) Handrails installed in addition to required handrails need not comply with Sentence (2).

9.8.7.5. Ergonomic Design

- a) A clearance of not less than 50 mm shall be provided between a handrail and any surface behind it.
- b) All handrails shall be constructed so as to be continually graspable along their entire length with no obstruction on or above them to break a handhold, except where the handrail is interrupted by newels at changes in direction. (See Appendix A.)

9.8.7.2. Continuity of Handrails

(See Appendix A.)

- 1) Except as provided in Sentence (2), at least one required handrail shall be continuous throughout the length of the stair or ramp, including landings, except where interrupted by
 - a) doorways, or
 - b) newel posts at changes in direction.
- 2) For stairs or ramps serving a single dwelling unit, or a house with a secondary suite including their common spaces, at least one required handrail shall be continuous throughout the length of the stair or ramp, except where interrupted by
 - a) doorways,
 - b) landings, or
 - c) newel posts at changes in direction.

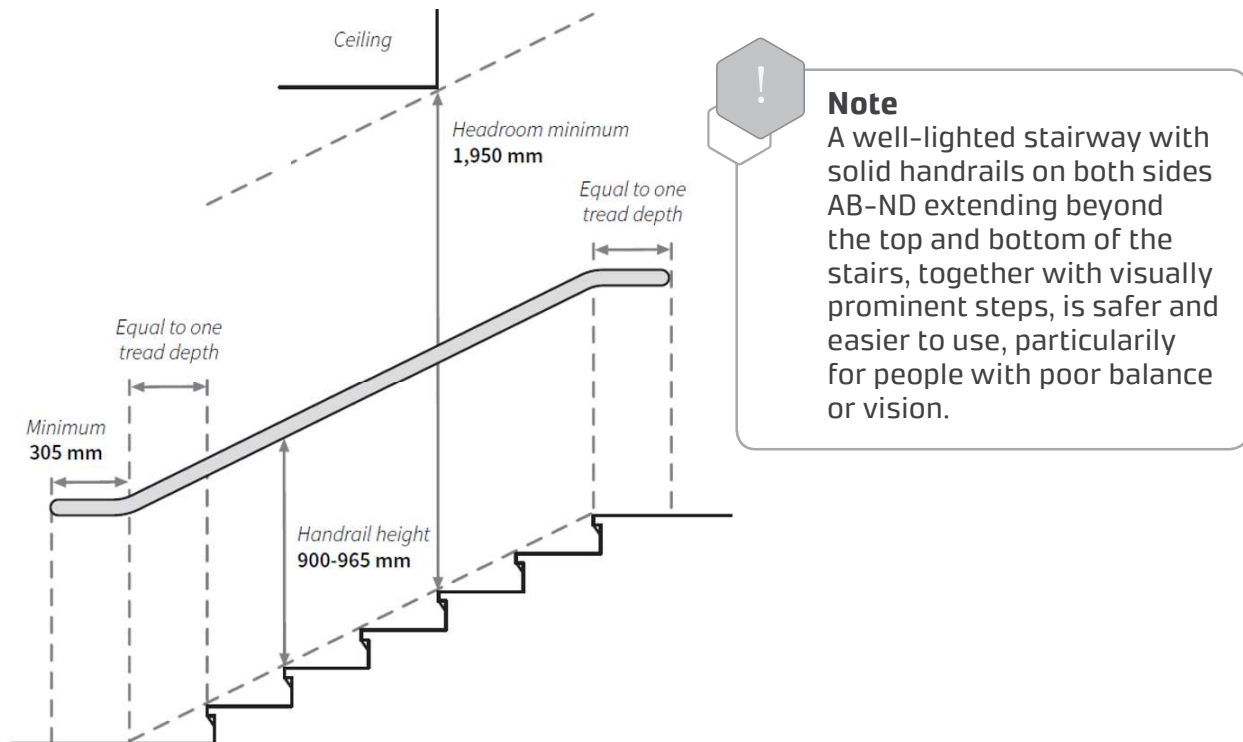

People with visual disabilities rely on handrails to guide them on stairways. A continuous handrail also provides assistance when climbing steps/stairs. It provides stability and a feeling of security for the elderly, particularly when they walk down the stairs.

9.8.7.3. Termination of Handrails

- 1) Handrails shall be terminated in a manner that will not obstruct pedestrian travel or create a hazard. (See Appendix A.)
- 2) Except for stairs and ramps serving only one dwelling unit or a house with a secondary suite including their common spaces, at least one handrail at the sides of a stair or ramp shall extend horizontally not less than 300 mm beyond the top and bottom of each flight or ramp. (See Appendix A.)

It is strongly recommended that a continuous handrail terminate by returning the ends into the wall. Where there is no wall, the rail should terminate in the ground to provide an effective surface for cane detectability. This greatly reduces the potential hazard for people with visual disabilities.

9.8.7.4. Height of Handrails

(See Appendix A.)

- 1) The height of handrails on stairs and ramps shall be measured vertically from the top of the handrail to
 - a) a straight line drawn tangent to the tread nosings of the stair served by the handrail, or
 - b) the surface of the ramp, floor or landing served by the handrail.



- 2) Except as provided in Sentences (3) and (4), the height of handrails on stairs and ramps shall be
 - a) not less than 865 mm, and
 - b) not more than 965 mm.
- 3) Where guards are required, handrails required on landings shall be not more than 1 070 mm in height.
- 4) Handrails installed in addition to required handrails need not comply with Sentence (2).

Elevators and Other Passenger-elevating Devices

Elevators and passenger-elevating devices are mechanical devices for moving people safely and efficiently from one level to another. This section deals with the safe movement of those using wheelchairs, scooters, or other mobility aids from one elevation to another.

3.8.3.5. Passenger-Elevating Devices

- 1) Where passenger elevators are used in a barrier-free path of travel, features described in Appendix E of ASME A17.1/CSA B44, “Safety Code for Elevators and Escalators,” shall be included in their design and construction.

Elevators

The following standards were developed by the Canadian Standards Association (CSA) to evaluate elevating devices. Reference the latest version of the Elevating Devices Codes Regulation prior to design and/or installation of the passenger-elevating device. In particular, review the harmonized codes in ASME A17.1-2013/CSA-B44-13, “Safety Code for Elevators and Escalators.”

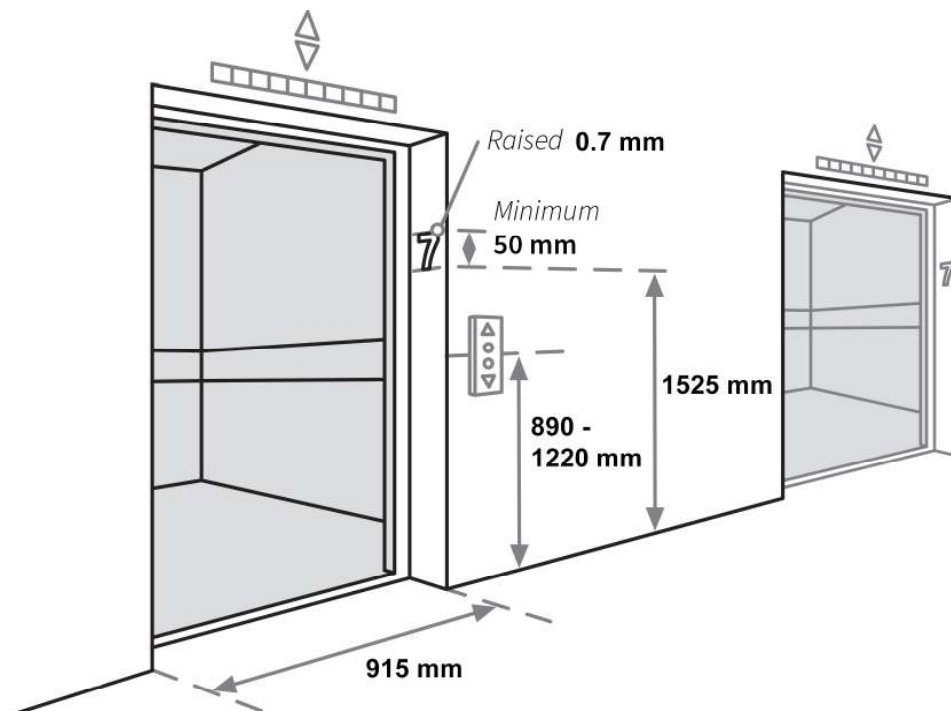

**Note**

Elevators shall be designed, installed, and maintained according to the ASME A17.1/CSA B44. See Appendix 1.

- 2) A platform-equipped passenger-elevating device used in a barrier-free path of travel shall conform to the elevating devices regulations made pursuant to the Safety Codes Act.

Lifts

CAN/CSA-B355-“Lifts for Persons with Physical Disabilities.”

4.2.1 Travel

The travel of a vertical platform lift shall not exceed the following

- (a) 2500 mm for unenclosed type; or
- (b) 7000 mm for enclosed type

**Note**

Lifts shall be designed, installed, and maintained according to CSA-B355.

**Note**

The Exemption Regulation 351/2003 exempts elevating devices that serve privately owned single-family dwellings from applying CAN/CSA-B613-00.

3.5.4.1. Elevator Car Dimensions

- 1) If one or more elevators are provided in a building, all storeys shall be served by at least one elevator which has inside dimensions that will accommodate and provide adequate access for a patient stretcher 2 010 mm long and 610 mm wide in the prone position. (See Appendix A.)
- 2) An elevator satisfying the requirements of Sentence (1) shall be clearly identified on the main entrance level of the building.

SECTION 4

The ABC requires that the elevator be sized to accommodate a stretcher 2 010 mm long and 610 mm wide.



Best Practice

In some circumstances, it is necessary to maintain a patient on a stretcher in the prone position during transit to a hospital or to treatment facilities. Inclining the stretcher to load it into an elevator could be fatal or detrimental to the patient's health. Many ambulance services use a mobile patient stretcher that measures 2 010 mm long and 610 mm wide. As well as space for the stretcher in the elevator, there should be sufficient additional space for at least two attendants who may be providing treatment during transit.

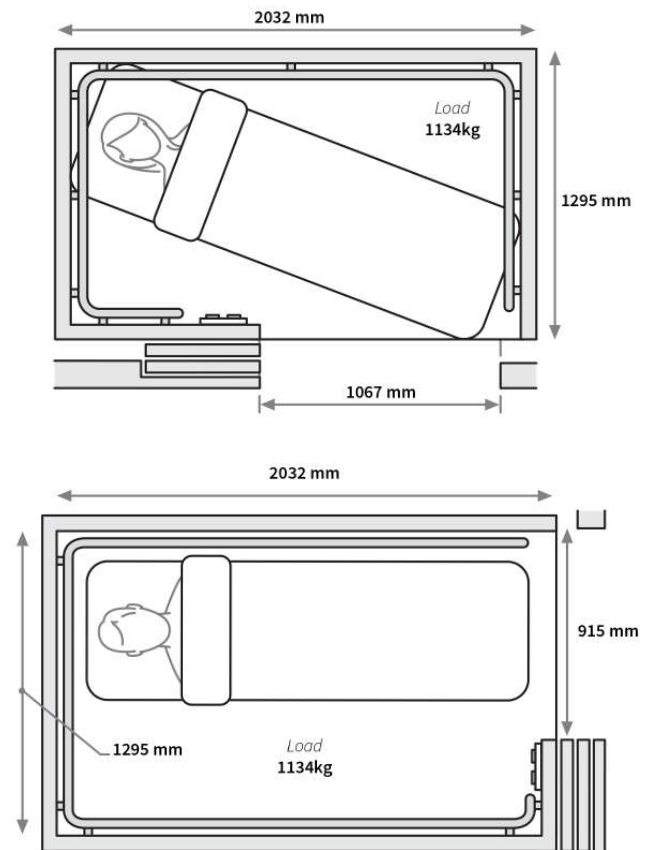

Building Code Variance

3.5.4.1(1) Elevator Car Dimensions

When a lift is required in a barrier-free path of travel but an elevator is used instead of a lift conforming to CSA-B355-“Lifts for Persons with Physical Disabilities,” the dimensions of the elevator car is not required to provide adequate access for a patient stretcher. However, the car cannot be less than the minimum as set out in Table 1 of CSA-B355, and the elevator is restricted to a maximum rise of 7000 mm.

For additional information, see STANDATA for elevating devices.

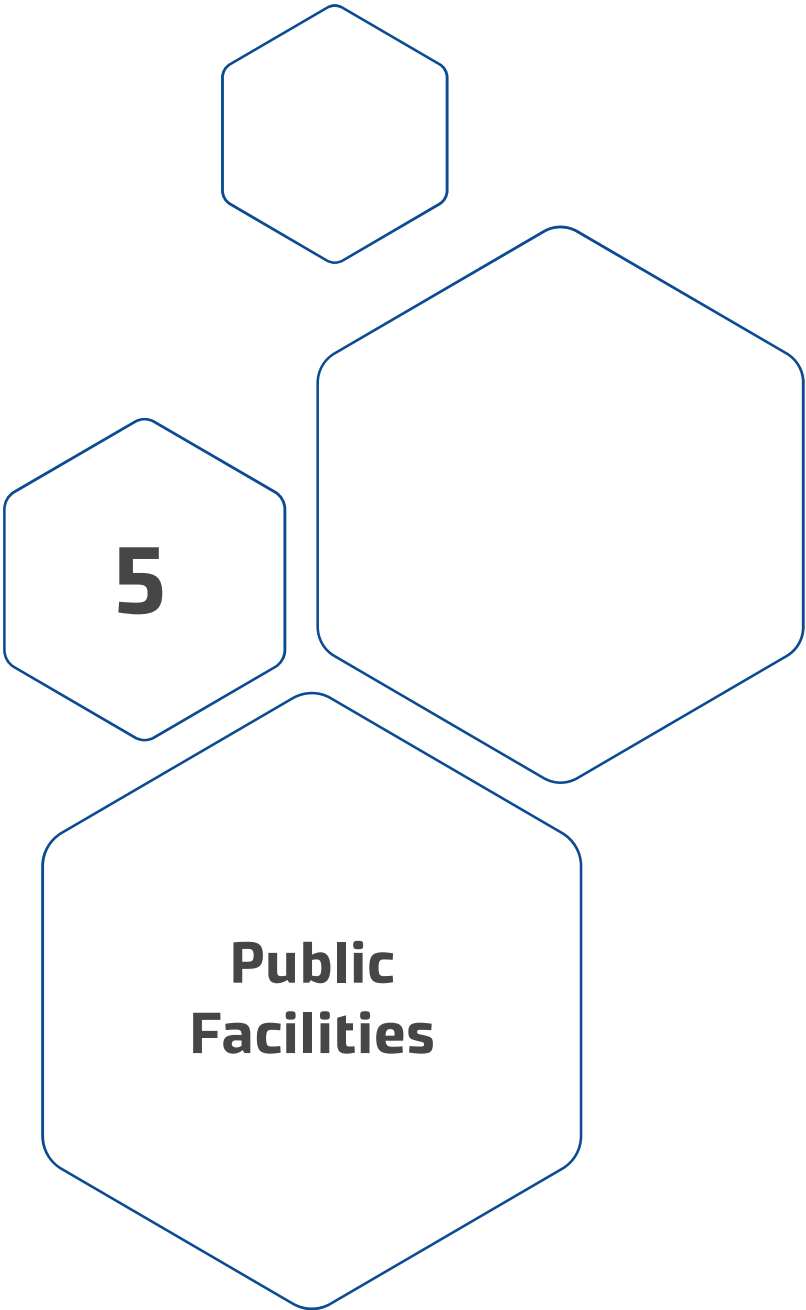



Public Facilities

It is important and necessary to ensure that all environments where the public is expected to visit will be accessible so that everyone is provided with the opportunity to participate freely and safely in their chosen community.

Public attendance or participation at a sporting event, concert, graduation, or play is important to everyone, including seniors and people with disabilities. Barrier-free access to a choice of seating in stadiums, theatres (stage and movie), outdoor bleachers, and arenas, plus the washrooms, eating areas, concession stands, banking amenities, ticket wickets, pay telephones, etc., must be available to allow full attendance or participation by all patrons.

Stadium and Theatre Seating

3.8.2.1. Areas Requiring a Barrier-Free Path of Travel

- 3) Unless a barrier-free path of travel is not required in an assembly occupancy by Clause (2)(i), the number of spaces designated for use by persons using wheelchairs within rooms or areas with fixed seats shall conform to Table 3.8.2.1. and be dispersed
 - a) in each floor level of seating,
 - b) in each price range of seating, and
 - c) in each viewing section of seating.

(See Article 3.8.3.6. for the design requirements.)

The number of seating spaces designated for people using wheelchairs in Article 3.8.2.1. shall be in accordance with Table 3.8.2.1.

Table 3.8.2.1. Designated Wheelchair Spaces Forming Part of Sentence 3.8.2.1.(3)	
Number of Fixed Seats in Seating Area	Number of Spaces Required for Wheelchairs
2 - 100	2
101 - 200	3
201 - 300	4
301 - 400	5
401 - 500	6
501 - 900	7
901 - 1300	8
1301 - 1700	9
each increment of up to 400 seats in excess of 1700	one additional space

Spaces that are designated for wheelchair users shall be scattered throughout the seating areas to allow a choice of locations on different levels and offer different price ranges.

3.8.3.6. Spaces in Seating Area

- 1) Spaces designated for use by persons using wheelchairs referred to in Sentence 3.8.2.1.(3) shall be
 - a) clear and level, or level with easily removable seating,
 - b) not less than 900 mm wide and 1 525 mm long to allow a person using a wheelchair to enter from a side approach and 1 220 mm long where the person using a wheelchair enters from the front or rear of the space,
 - c) arranged so that at least 2 designated spaces are side by side,
 - d) located adjoining a barrier-free path of travel without infringing on egress from any row of seating or any aisle requirements, and
 - e) situated, as part of the designated seating plan, to provide a choice of viewing locations and a clear view of the event taking place.

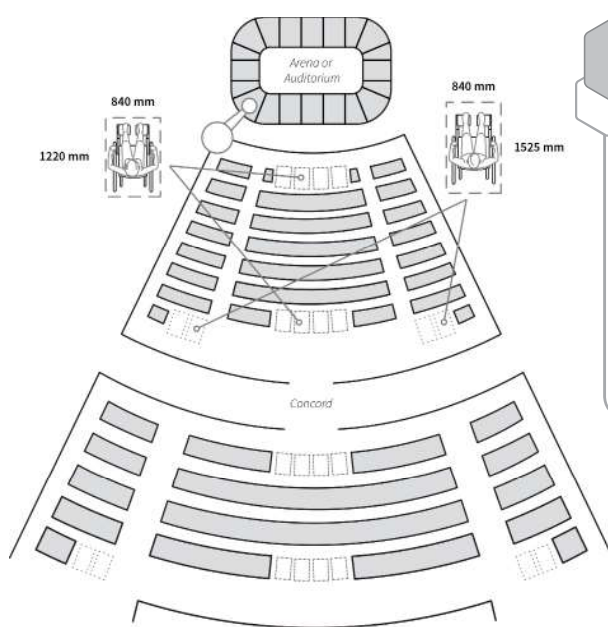

Note

Thoughtful design should consider the incorporation of both manual and power wheelchair seating and space for other mobility devices (such as scooters) in viewing areas; they will take up more space than normal seating. They will need approximately 1½ regular-sized seats in width and 2-3 in length.

Best Practice

The demand for accessible seating has increased in recent years, especially at venues that are used for sporting events and other entertainments such as concerts and monster truck events. It is recommended that the accessible seating to be allocated from 0.005-0.0075% of the total number of seats in the arena. This percentage also includes the companion seat because most people enjoy sharing the experience of a sports event or other entertainment with at least 1 friend or family member.

To address the concerns that these spaces may be unused, at the last moment portable chairs can be used to increase sales. For example, 20 000 x 0.0075=150.

Note

Sightlines for the viewing pleasure and comfort of seated persons need to be considered when designing wheelchair spaces. Viewing can be blocked when patrons or fans stand up in front of the designated wheelchair spaces to cheer or applaud.

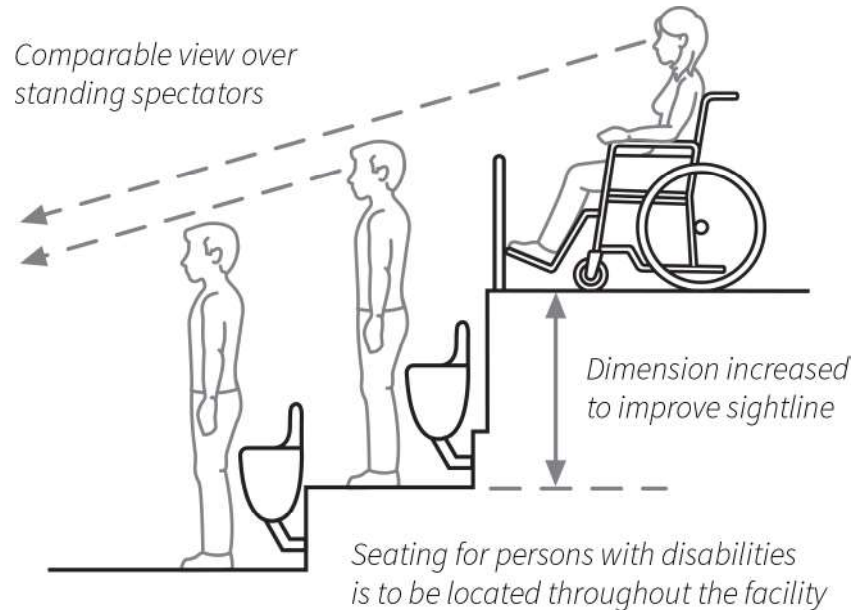
**Amenities**

Spending time with family and friends is always more enjoyable when the facilities and amenities have barrier-free access, allowing for independence and safety.

3.8.3.14. Counters

- 1) Every counter more than 2 m long, at which the public is served, shall have at least one barrier-free section not less than 760 mm long centred over a knee space conforming to Sentence (3). (See Appendix A., especially A-3.8.2.1.)

Sentence (1) requires that every counter more than 2 m in length that serves the public shall have a barrier-free section. The only accepted exceptions to Sentence (1) are bar counters in drinking establishments, and ONLY if a reasonable alternative for seating is provided for patrons who use wheelchairs or scooters. For example, reasonable alternatives may be dining or bistro tables or wall-mounted units that comply with Sentence (3).

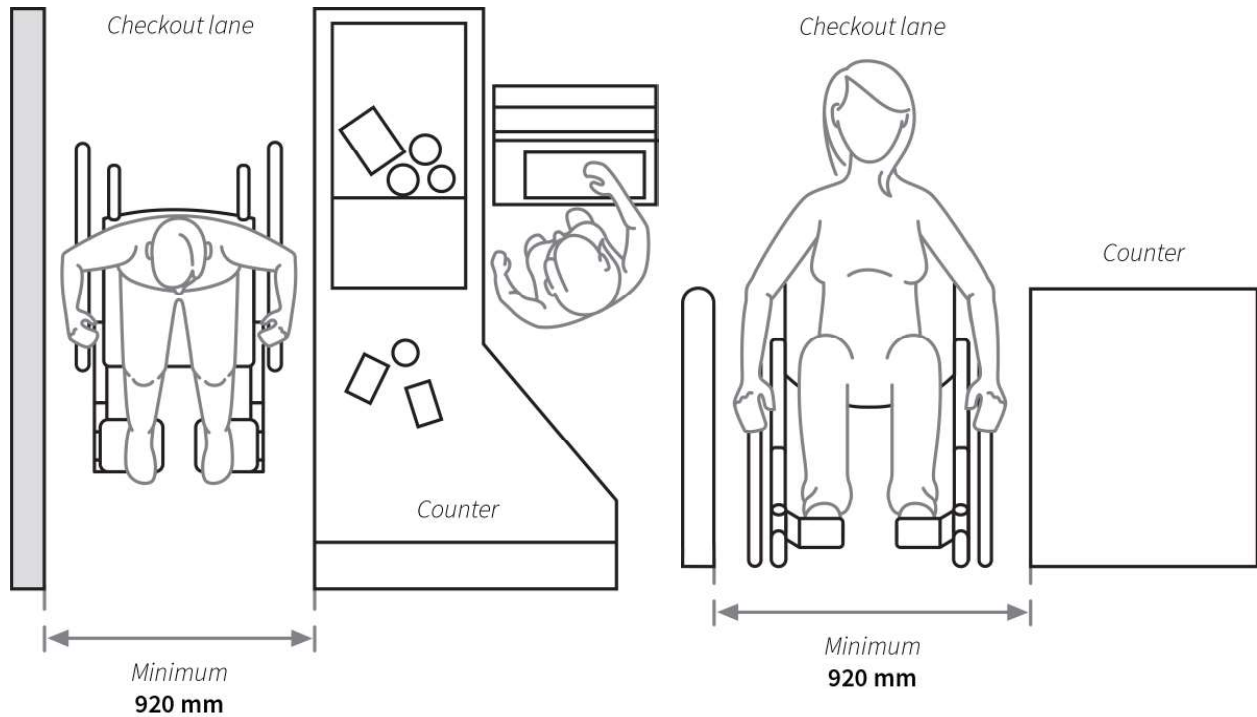

- 2) A barrier-free counter surface shall not be more than 865 mm above the floor.
- 3) Except as permitted in Sentence (4), the knee space beneath a barrier-free counter intended to be used as a work surface shall not be less than
 - a) 760 mm wide,
 - b) 685 mm high, and
 - c) 485 mm deep.

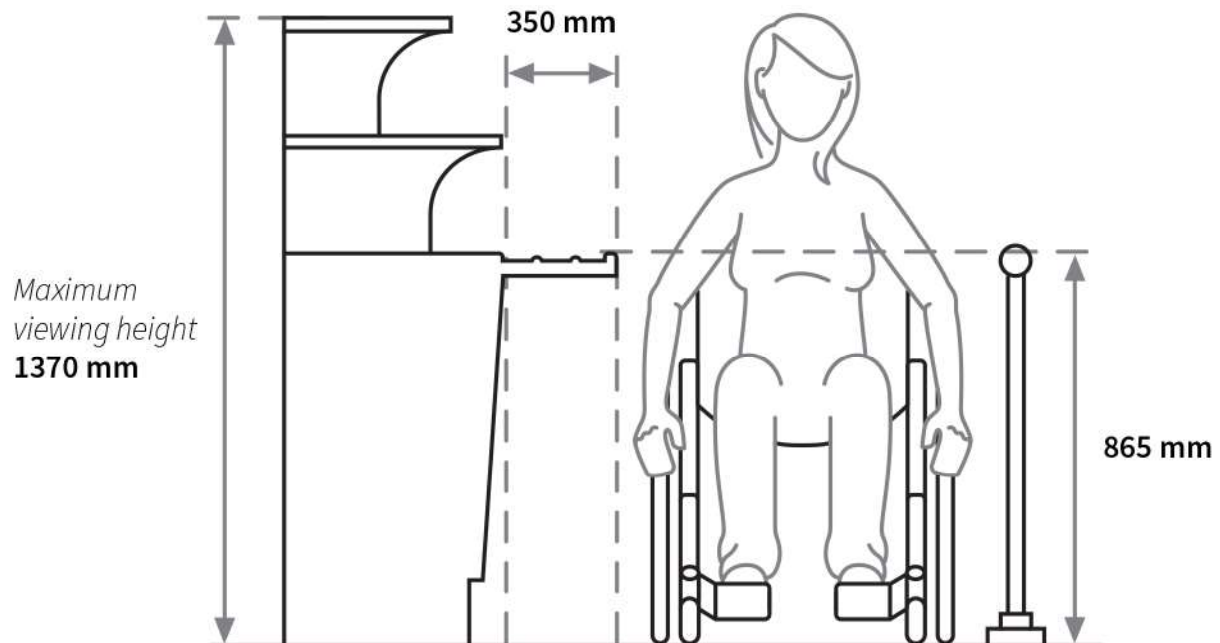

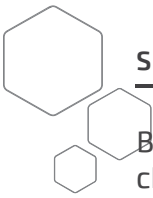

SECTION 5

Banks shall also conform to Sentences (2) and (3) when designing service counters for clients who may use a wheelchair or other mobility device, and for seniors who prefer to sit while conducting their banking. The same standards should be applied when installing accessible ATMs for users of wheelchairs and other mobility devices.

- 4) A counter that is used in a cafeteria, or one that performs a similar function whereat movement takes place parallel to the counter, need not provide a knee space underneath it.

3.8.3.16. Drinking Fountains

- 1) If drinking fountains are provided, at least one shall be barrier-free and shall
 - a) have a spout located near the front of the unit not more than 915 mm above the floor, and
 - b) be equipped with controls that are easily operable from a wheelchair using one hand with a force of not more than 22 N, or be automatically operable.

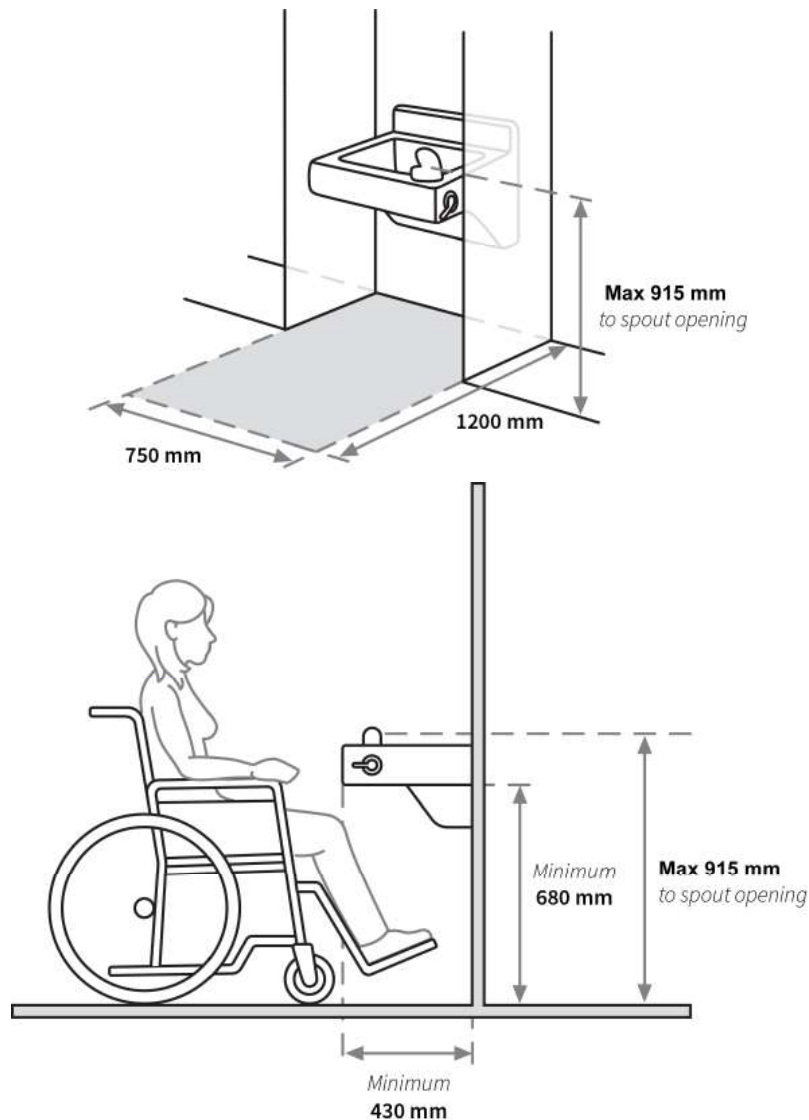

Commercially available drinking fountains having two spouts at varying heights are ideally suited to both people using wheelchairs and people who find it difficult and awkward to bend down. One spout shall not be more than 915 mm high. The recommended height for the higher spout is 1 050 mm, measured from the floor to the mouth of the spout.

The location and design of drinking fountains may be hazardous for building users with visual disabilities. While there shall be adequate space under or adjacent to the drinking fountain for people using wheelchairs or scooters, there should also be cane detectability for a person using a white cane. This means that, when the fountain is located in a barrier-free path of travel, a partition or cane-detectable barrier on each side of the wall-mounted drinking fountain should be provided. Enough space should still be provided between the partitions for persons who use wheelchairs or scooters.

Other Obstacles

Telephone kiosks, fire extinguishers, and vending machines should be recessed on a barrier-free path of travel to prevent them from being obstacles to persons with visual disabilities. Their design and location may make them impossible to detect with only the sweep of a white cane.

Planters and ashtrays should be recessed or located alongside the designated barrier-free path of travel. The bottom edges of signs and the bases of wall lighting fixtures should be located no lower than 2 m, measured from the finished floor surface, to prevent them from being hazards to persons with visual disabilities.

Building Controls

3.8.1.5. Controls

- 1) Except as required by Sentence 3.5.2.1.(3) and Article 3.8.3.5. for elevators and platform-equipped passenger-elevating devices, controls for the operation of building services or safety devices, including electrical switches, thermostats and intercom switches, that are intended to be operated by the occupant and are located in or adjacent to a barrier-free path of travel shall be accessible to a person in a wheelchair, operable with one hand and mounted between 400 mm and 1 200 mm above the floor.



Best Practice

Pull stations (emergency/fire), thermostats, (in-home) security/alarm panels, and other controls for the operation of building services shall be accessible to a person using a wheelchair. These controls are best located no higher than 1 200 mm and no lower than 850 mm above the floor.

Raised lettering and/or Braille should be added to help persons with visual disabilities to access building service controls. Building controls should be easy to find by using colour contrast to the background for ease of identification; in particular, by persons with visual disabilities.

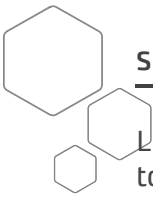

SECTION 5

Light switches should be located between 1 100 mm and 1 200 mm above the finished floor to improve access for people in wheelchairs who may have a limited range of motion.

Electrical outlets should be located at a minimum of 650 mm when measured from the centre of the plate to the finished floor to minimize the reaching or bending for all users (including people in wheelchairs).

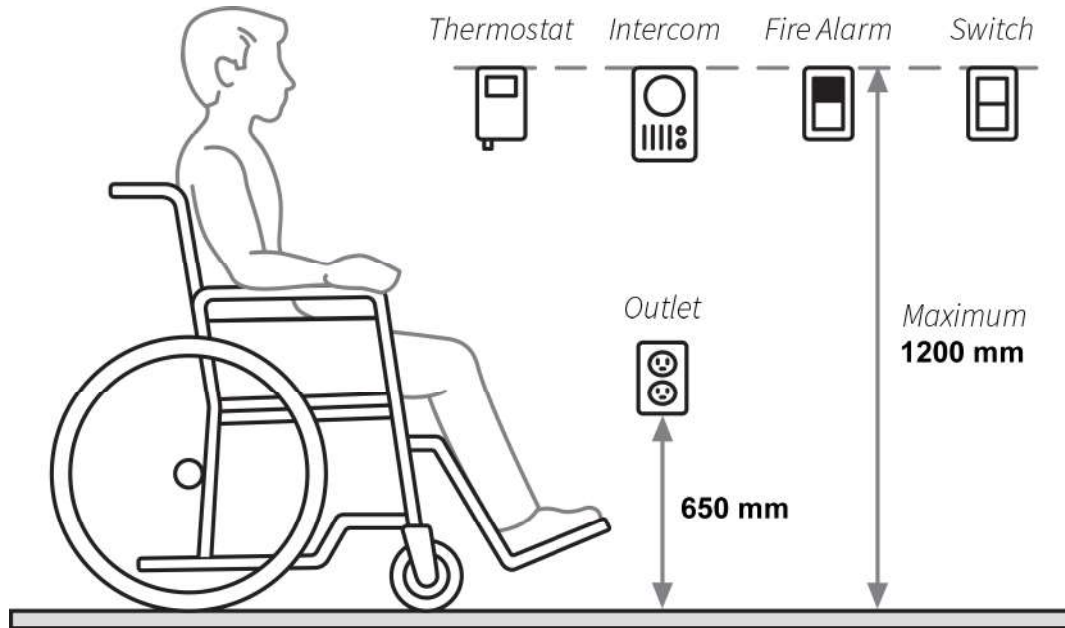

Public Washrooms

3.8.2.3. Washrooms Required to be Barrier-Free

(See Appendix A.)

- 1) Except as permitted by Sentence (2), all washrooms in a barrier-free path of travel shall be barrier-free in accordance with the appropriate requirements in Articles 3.8.3.8. to 3.8.3.12.
- 2) A washroom need not conform to the requirements of Sentence (1) provided it is located
 - a) within a suite of residential occupancy or a suite of care occupancy that has not been designated by Sentence 3.8.4.1.(1) to be accessible, or
 - b) in an individual suite having an area less than 500 m² and there are barrier-free washrooms on the same floor area within 45 m.
- 3) In a building in which water closets are required in accordance with Subsection 7.2.3., at least one barrier-free water closet shall be provided in the entrance storey, unless
 - a) a barrier-free path of travel is provided to barrier-free water closets elsewhere in the building, or
 - b) the water closets required by Subsection 7.2.3. are for dwelling units only.

- 4) If alterations are made to an existing building, universal toilet rooms conforming to Article 3.8.3.12. are permitted to be provided, in lieu of facilities for persons with physical disabilities in washrooms used by the general public.
- 5) In addition to the requirements of Sentence (1), at least one universal toilet room conforming to Article 3.8.3.12. shall be provided in a regional transportation terminal.
- 6) If more than one water closet is provided in a washroom, a barrier-free stall shall be provided for every 10 stalls or part thereof.
- 7) For temporary uses, such as outdoor fairs and festivals, a barrier-free stall shall be provided for every 10 stalls or part thereof.

All washrooms for use by the public shall be made barrier-free using the design standards described previously; however, Clause (2)(b) shall be the exception. With respect to strip malls or other suites and buildings with an exterior sidewalk or other barrier-free path of travel, it is unreasonable to expect the consumer to leave the premises in search of a barrier-free washroom. Therefore, it is preferred that all suites, including those 500 m² or less, where the public is expected to have access to washrooms that are barrier-free, have a universal toilet room as an acceptable solution.

Units in a single-family dwelling that are used for social programs also require barrier-free washrooms, with no exceptions.

Existing buildings that are being renovated must comply with the requirements of current codes. In circumstances where this may not be possible, an alternate solution is acceptable. A separate washroom described as a universal toilet room (see the following section) is the preferred alternative when space is limited or it becomes cost prohibitive to make each set of washrooms accessible.



Note

If this alternative is still not possible, the owner or designer should seek assistance from local disability organizations or advisory committees that deal with disability issues and concerns.



Note

Owners and designers should consider it for all new building construction (and renovations, wherever possible). A washroom designed with a maze entrance is a truer barrier-free washroom. Where a maze entrance exists for a public washroom, the floor finish shall be slip-resistant and be high in colour contrast to the wall finish. This is to provide safe and appropriate wayfinding for people who have visual disabilities, but some residual vision.

Note

If an alternative or exemption is desired, an application for barrier-free relaxation is required to be submitted to Alberta Municipal Affairs. Only the Chief Building Administrator has the authority to grant a relaxation.

3.8.3.11. Lavatories

- 1) A barrier-free washroom shall be provided with a lavatory that
 - a) is located so that the distance between the centreline of the lavatory and the side wall is not less than 460 mm,
 - b) has a rim height not more than 865 mm above the floor,
 - c) has a clearance beneath the lavatory not less than
 - i) 760 mm wide,
 - ii) 735 mm high at the front edge,
 - iii) 685 mm high at a point 205 mm back from the front edge, and
 - iv) 230 mm high over the distance from a point 280 mm to a point 430 mm back from the front edge (see Appendix A),
 - d) has insulated pipes where they would otherwise present a burn hazard (See Appendix A),
 - e) has a soap dispenser located close to the lavatory, not more than 1 200 mm above the floor and accessible to persons in wheelchairs, and
 - f) has a towel dispenser or other hand-drying equipment located close to the lavatory, not more than 1 200 mm above the floor in an area that is accessible to persons in wheelchairs.

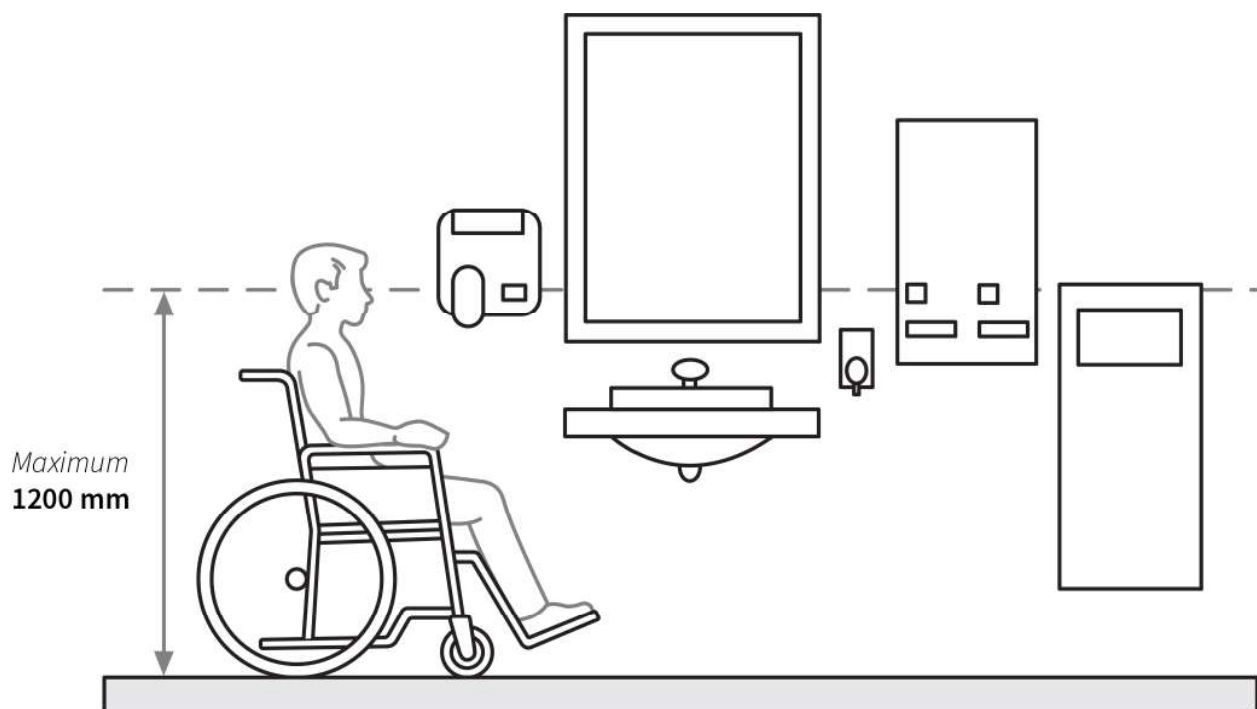

Protection from Burns

Hot-water and drain pipes under lavatories shall be insulated to prevent the pipes from becoming a burn hazard to persons who use wheelchairs. Not all individuals have the ability to sense heat or prevent prolonged contact with the pipes.

Article 7.1.2.2. Burn Prevention

- 1) If the authority having jurisdiction deems it necessary to protect children, the elderly, or persons with disabilities or infirmities from burns,
 - a) piping used to distribute service hot water and other hot water in assembly occupancies, care occupancies, treatment occupancies, detention occupancies and residential occupancies shall be concealed or insulated, and
 - b) the temperature of the water from faucets shall be limited to a maximum of 49°C.

It is strongly recommended that care facilities heat water to a temperature above 70°C and then lower it, or use a temperature regulator, to prevent accidental scalding.

Mirrors

3.8.3.11. Lavatories

- 2) If mirrors are provided in a barrier-free washroom, at least one mirror shall be
 - a) mounted with its bottom edge not more than 1 000 mm above the floor, or
 - b) be inclined to the vertical to be usable by a person in a wheelchair.

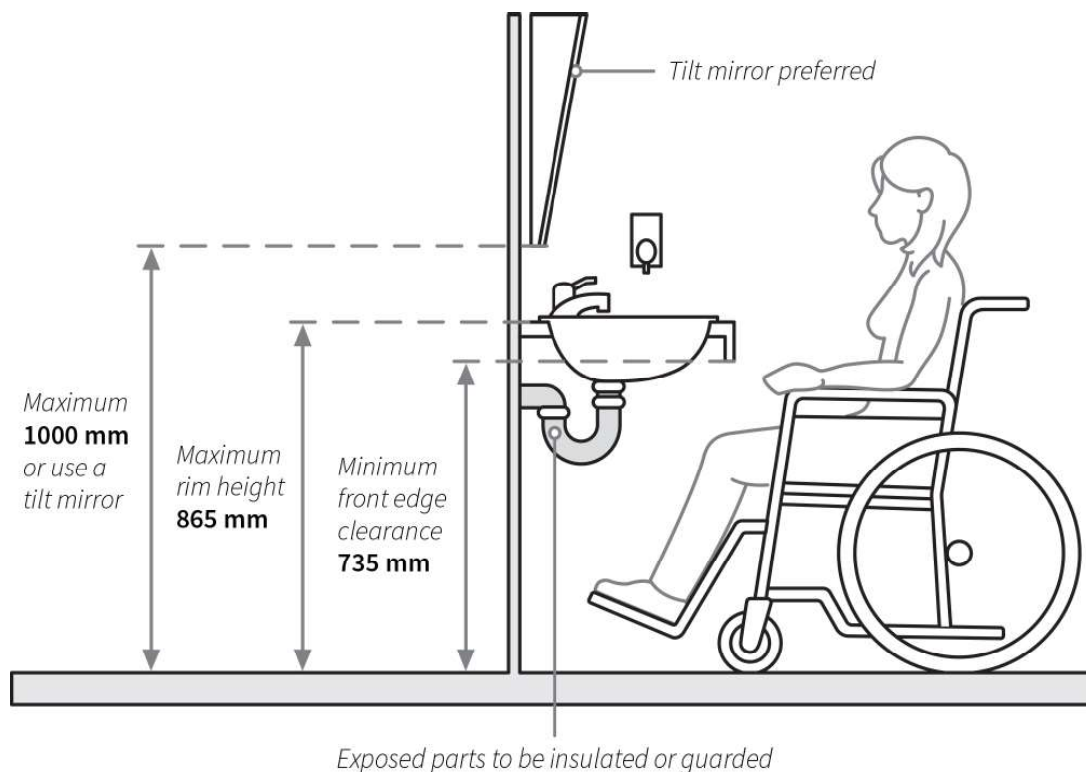

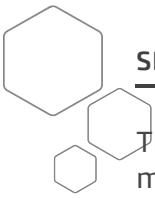

SECTION 5

Tilt mirrors are preferred to lowered mirrors that are mounted above the lavatory. The mirror should be mounted no more than 200 mm above the lavatory when measured from the surface of the sink or counter. This will allow a person who uses a wheelchair to visually scan their reflection from head to floor. Where a tilt mirror is provided, designers are advised to consider that taller individuals with visual disabilities may find the mirror a potential hazard. Inset the tilt mirror or increasing the depth of the vanity would solve this potential problem. If no tilt mirror is provided, then, in addition to having the mirror mounted above the lavatory, a wall-mounted full length mirror is an acceptable alternative.

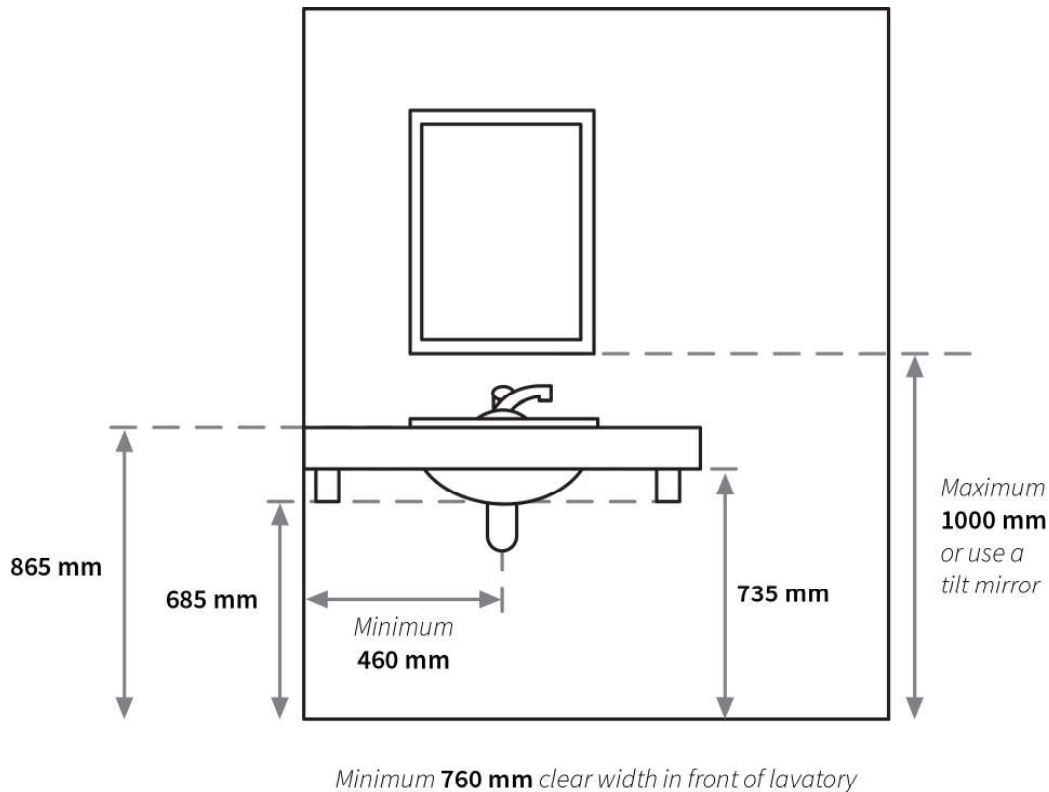

Faucets

Automatic water controls are a preferred alternative to levered handle faucets. However, single-lever faucet controls are preferred to separate hot and cold lever handles. Valves used in large complexes are different from those used in single-family homes. In single-family homes, mechanical stops are sometimes used to prevent scalding; however, these must be reset when the temperature is adjusted at the hot-water heater. A better alternative is a water temperature regulator for use in public spaces.

3.7.2.3. Lavatories

- 3) Any shelf or projection above a lavatory shall be located so that it will not be a hazard.
- 4) Lavatories required by Sentence (1) shall be equipped with faucets that
 - a) operate automatically, or
 - b) have lever-type handles that do not close under spring action.

Faucets and shelves should be of contrasting colour to the surfaces to which they are attached. This will help those with visual disabilities to identify them.

Universal Toilet Rooms

A universal toilet room is required to accommodate a user and a family member or an attendant of the opposite gender so that hygiene may be carried out with dignity and in private. A regional transportation terminal is required to provide universal toilet rooms as the preferred alternative to washroom facilities on buses, trains, and planes, which are small and difficult to use. Universal toilet rooms are recommended in shopping centres. Universal toilet rooms are also useful to parents who have young children who cannot be left alone or require extra attention.

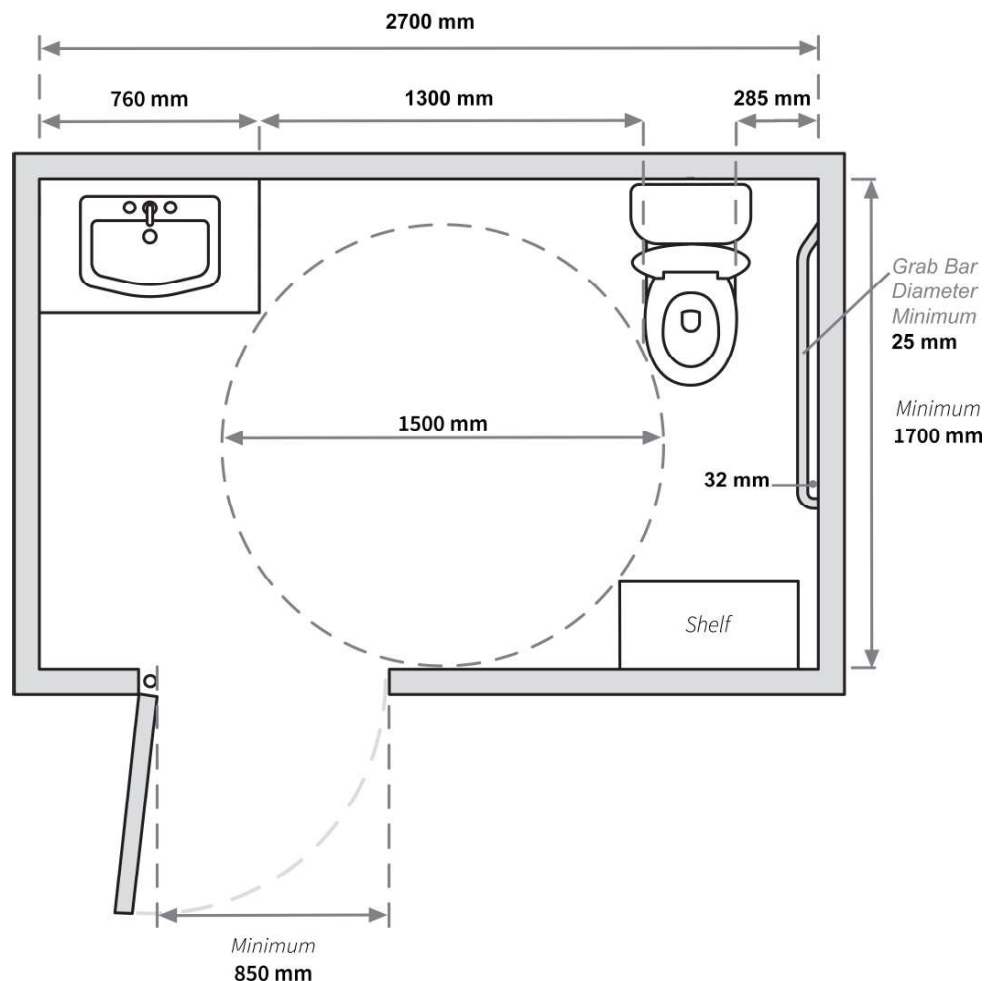



3.8.3.12. Universal Toilet Rooms

(See Appendix A.)

- 1) A universal toilet room shall
 - a) be served by a barrier-free path of travel,
 - b) have a door capable of being locked from the inside and released from the outside in case of emergency and having
 - i) a latch-operating mechanism that is operable with a closed fist, located not less than 900 mm and not more than 1 000 mm above the floor,
 - ii) if it is an outward-swinging door, a door pull not less than 140 mm long located on the inside so that its midpoint is not less than 200 mm and not more than 300 mm from the hinged side of the door and not less than 900 mm and not more than 1 000 mm above the floor (See A-3.8.3.8.(1)(b)(iv) in Appendix A), and
 - iii) if it is an outward-swinging door, a door closer, spring hinges or gravity hinges, so that the door closes automatically,
 - c) have one lavatory conforming to Article 3.8.3.11.,
 - d) have one water closet conforming to the requirements of Article 3.8.3.9., that has a clearance to the walls of
 - i) not less than 285 mm and not more than 305 mm on one side, and
 - ii) not less than 875 mm on the other side,
 - e) have grab bars conforming to Clause 3.8.3.8.(1)(d),
 - f) have no internal dimension between the walls that is less than 1 700 mm,
 - g) have a coat hook conforming to Clause 3.8.3.8.(1)(e), and a shelf located not more than 1 200 mm above the floor,
 - h) be designed to permit a wheelchair to back in alongside the water closet in the space referred to in Subclause (d) (ii), and
 - i) be designed to permit a wheelchair to turn in an open space not less than 1 500 mm in diameter.

A universal toilet room is a self-contained facility that can be used by either sex. Universal toilet rooms allow a person who may require assistance to use the facility in comfort and in private. Self-contained washrooms are of significant benefit under these circumstances.



Note

The measurements in the ABC are based upon a person using a manual wheelchair. Some measurements that follow are greater than the ABC. The increased measurements are based on persons using power wheelchairs, which are generally taller and wider.

The features that are important in a universal toilet room are as follows:

- The doorway will have a clear opening of 850 mm (900 mm is preferred) and must be easy to open and close.
- A locking mechanism must be easy to access and operate by a person using a wheelchair or a senior with limited strength and/or agility in hands and/or wrists. A sliding latch with a larger grasping surface, or a push-button mechanism, located 950 ± 50 mm from the floor would suffice.
- If the door swings outward, at least a 300-mm D-shaped handle is needed to pull the door shut, if it is not self-closing. The handle should be located horizontally on the inside of the door and installed at 150 mm from the hinge side and 950 mm from the floor, ± 50 mm in either direction. It is recommended that automatic door openers on both the interior and exterior of the washroom be installed for ease of entry and egress.
- It is preferred that the lavatory should have a clearance of 870 mm measured from the lowest part of the apron to the floor to allow a person in a wheelchair to manoeuvre beneath the sink. The rim height of the sink or top of the counter may not be greater than 875 mm when measured from the surface to the finished floor.
- The drain pipes beneath the lavatory should be offset and insulated to permit the person in a wheelchair to manoeuvre as far in as possible without burning limbs on exposed plumbing. It is recommended that exposed pipes—whether offset or not—be insulated to prevent burns.
- The toilet shall be no lower than $430 \text{ mm} \pm 30 \text{ mm}$ when measured from the floor to the surface of the toilet seat.
- The horizontal grab bar located adjacent to the water closet shall be installed 500 mm from the wall to the midpoint of the grab bar. It is preferred that the grab bar be L-shaped (i.e., 1 200 mm horizontal and 600 mm diagonal lengths). In addition, a 900 mm-length grab bar should be located at the back of the toilet if there is no toilet tank (the lid should be secured to the tank for stability).
- A coat hook of a button (or similar) design should be located not less than 1 100 mm from the floor, and measured to the centre line of the hook, in order to not be a hazard to people with visual disabilities.



Note

The L-shaped grab bar should have the diagonal installed forward of the toilet and above the horizontal grab bar. This accessory is available for either the left or right side of the toilet.

- 1) The water closet stall or universal toilet room should have a dimension of not less than 2 100 mm \times 1 700 mm to permit a person using a wheelchair or other mobility device to manoeuvre more easily within the space, i.e., to back in alongside the toilet or in front of the toilet.

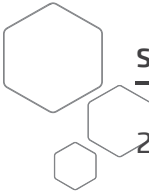
- 
- 2) Dispensers (measured from finished floor surface to centerline of dispenser)
 - a) Toilet paper dispenser: 750 mm-850 mm
 - b) Paper towel dispenser or hand dryer: 1 100 mm-1 200 mm
 - c) Soap: 900 mm-1 000 mm
 - d) Other dispensers: 1 100 mm-1 200 mm

**Note**

The soap dispenser should be located at the front and side of the sink for ease of access.

The following requirements are only those relating to the implementation of universal toilet rooms.

3.7.2.2. Water Closets

- 1) Except as permitted by Sentence (4), water closets shall be provided for each sex assuming that the occupant load is equally divided between males and females, unless the proportion of each sex expected in the building can be determined with reasonable accuracy. (See Appendix A.)
- 2) If a single universal toilet room is provided in accordance with the requirements of Section 3.8., the total number of persons in the building used to determine the number of water closets to be provided, is permitted to be reduced by 10 before applying Sentences (6), (7), (8), (12), (13) or (14).
- 3) Except as permitted by Sentence (2), if only one universal toilet room is provided in accordance with Section 3.8., the water closet in this room shall not be taken into consideration in determining the number of water closets required by this Article, unless a single water closet is permitted in accordance with Sentence (4).
- 4) Both sexes are permitted to be served by a single water closet if the occupant load in an occupancy referred to in Sentence (6), (10), (12), (13), (14) or (16) is not more than 10.
- 6) Except as permitted by Sentences (4), (7) and (8), the number of water closets required for assembly occupancies shall conform to Table 3.7.2.2.A.
- 7) The number of water closets required for primary schools and daycare centres shall be at least one for each 30 males and one for each 25 females.
- 8) The number of water closets required for places of worship and undertaking premises shall be at least one for each 150 persons of each sex.
- 9) The number of water closets required for a treatment or detention occupancy shall be determined on the basis of the special needs of the occupancy.

- 12) Except as permitted by Sentence (4), the number of water closets required for a business and personal services occupancy shall conform to Table 3.7.2.2.B.
- 13) Except as permitted by Sentences (4) and (16), the number of water closets required for a mercantile occupancy shall be at least one for each 300 males and one for each 150 females.
- 14) Except as permitted by Sentence (4), the number of water closets required for an industrial occupancy shall conform to Table 3.7.2.2.C.
- 16) The number of water closets required in a suite of mercantile occupancy whose area is not more than 500 m² is permitted to be determined in accordance with Table 3.7.2.2.B. based solely on the total number of staff.

The 2014 ABC requires separate male and female barrier-free universal toilet rooms. However, a relaxation may be granted to allow for a single barrier-free universal toilet room or a single barrier-free universal plus 1 or more non-barrier-free universal washroom(s) if the area is 500 m² and if the occupancy is:

- mercantile occupancy, i.e., boutique retail, sporting goods
- industrial occupancy
- places of worship and undertaking premises
- daycare centres
- business and personal services
- fast food and coffee bar occupancy
- convenience and liquor stores



Note

Applications for a relaxation are assessed on a case-by-case basis. It is the applicant's responsibility to provide all the supporting documentation after the Municipality or its approved agency has reviewed the request for a building permit.



Note

The submission of an Application for the Relaxation of Requirements for the Disabled does not guarantee a relaxation of barrier-free requirements will be granted by the Chief Building Administrator and Barrier-Free Administrator.

See Section II Barrier-Free Relaxations in this Guide for additional information.

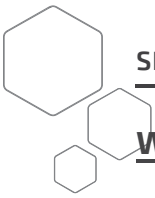

Water Closet Stalls

The following requirements are only those relating to the design of water closet stalls.

3.8.3.8. Water Closet Stalls

- 1) A water closet stall or enclosure in a washroom required by Article 3.8.2.3. to be barrier-free shall
 - a) be designed to allow a person using a wheelchair to turn in an open space that has a diameter of not less than 1 500 mm,
 - b) be equipped with a door that
 - i. can be latched from the inside with a closed fist,
 - ii. provides a clear opening of not less than 800 mm wide with the door in the open position,
 - iii. swings outward, unless sufficient room is provided within the stall or enclosure to allow the door to be closed without interfering with the person using a wheelchair (see Appendix A),
 - iv. is provided with a door pull on the inside not less than 140 mm long located so that its midpoint is not less than 200 mm and not more than 300 mm from the hinged side of the door and not less than 900 mm and not more than 1 000 mm from the floor (see Appendix A), and
 - v. is provided with a door pull on the outside, near the latch side of the door,
 - c) have a water closet located so that its centre line is not less than 460 mm and not more than 480 mm from an adjacent side wall on one side,
 - d) be equipped with knurled finished grab bars as described in Sentence (2),
 - e) be equipped with a coat hook mounted not more than 1 200 mm above the floor on a side wall and projecting not more than 50 mm from the wall, and
 - f) have a clearance of not less than 1 700 mm between the outside of the stall face and the face of an in-swinging washroom door and 1 400 mm between the outside of the stall face and any wall-mounted fixture.
- 2) A grab bar required by Sentence (1) shall
 - a) be mounted
 - i. horizontally on the wall beside the water closet, and be not less than 1200 mm in length, located with its centreline between 300 mm and 330 mm above the height of the water closet seat and with its midpoint located in line with the front edge of the water closet or
 - ii. on the wall beside the water closet and have a horizontal portion 600 mm in length with a 600 mm extension extending upwards to the front and away from the horizontal portion at an angle of 60° to the horizontal, with the centre line of the horizontal portion between 300 mm and 330 mm above the height of the water closet seat and the intersection of the horizontal and sloping portions located in line with the front edge of the water closet,
 - b) be mounted horizontally on the wall behind the water closet, if the water closet does not have an attached water tank, centred on the toilet bowl and be not less than 600 mm in length,

- c) be installed to resist a load not less than 1.3 kN applied vertically or horizontally,
- d) be not less than 30 mm and not more than 40 mm in diameter, and
- e) have a clearance of not less than 35 mm and not more than 45 mm from the wall.
(See Appendix A.)

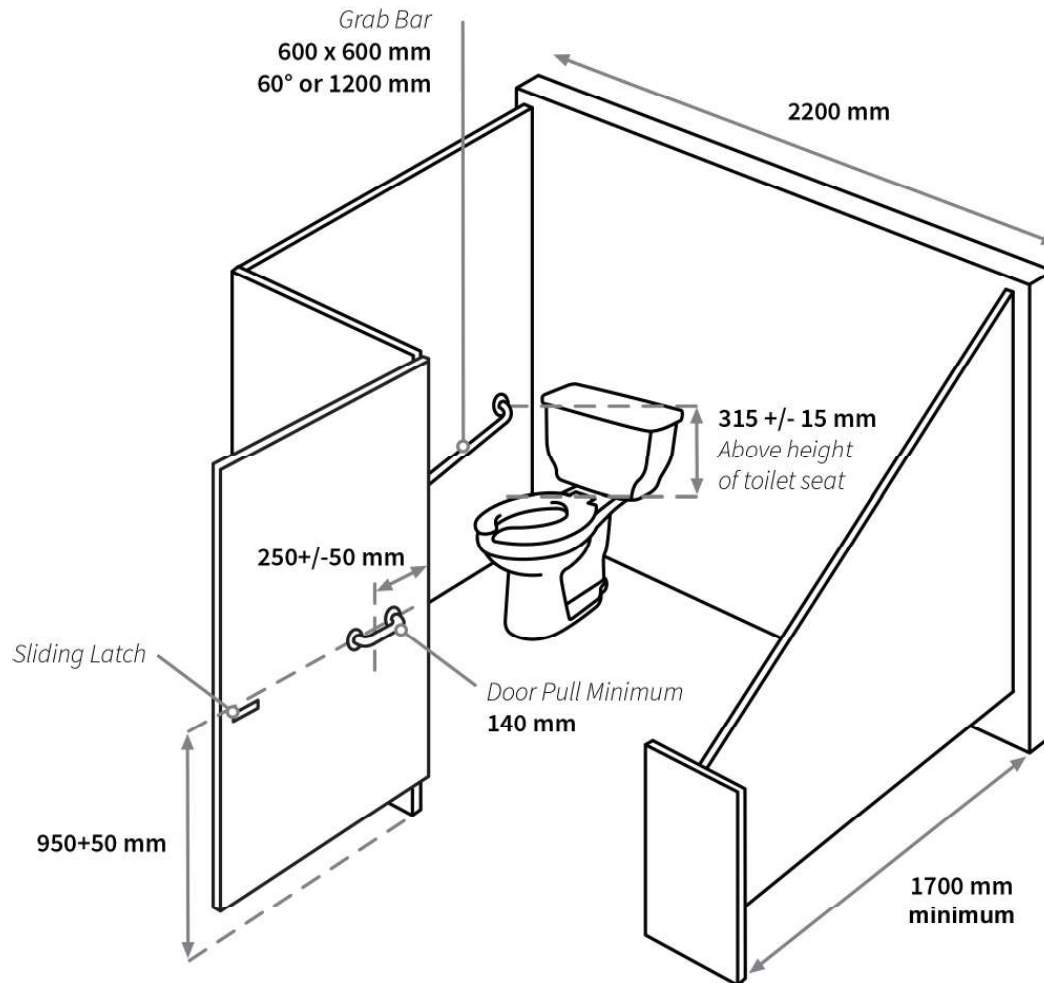

Stall Doors:

Where doors to water closet stalls swing outward, it is preferred that they swing against a side wall so as not to impede the flow of traffic or cause injury to a person passing by on the other side of the stall door. If the door of the stall swings inward, there should be an additional 900 mm of space to allow an occupant in a wheelchair to close the door from within the stall.

Door Pulls:

The door pull should be a D-shaped handle at least 140 mm in length and mounted in a horizontal position to allow for optimal leverage. The midpoint of the handle shall be located not less than 200 mm from the edge of the door on the hinged side. As well, measured from the midpoint to the floor, the handle shall not be less than 900 mm and not more than 1 000 mm.

Backing for Grab Bar Installation:

Sufficient backing (at least a 19 mm sheet of plywood or reasonable alternative behind cement board, floor to ceiling, is preferred for optimum strength and placement) is required for the installation of grab bars—in both vertical and horizontal positions—and towel bars, etc. Grab bars shall resist a load of 1.3 kN (132 kg) applied vertically or horizontally in water closet stalls, universal toilet rooms, change rooms, showers and bathing areas.

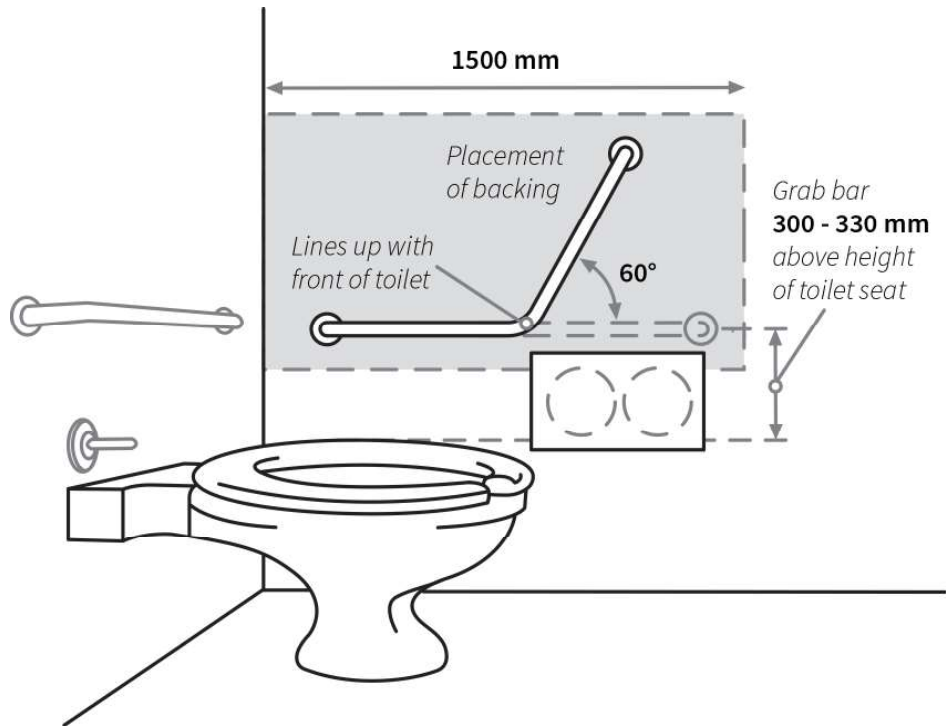
**Water Closets and Urinals****3.8.3.9. Water Closets**

- 1) A water closet for a person with physical disabilities shall
 - a) be equipped with a seat located at not less than 400 mm and not more than 460 mm above the floor,
 - b) be equipped with hand-operated flushing controls that are easily accessible to a wheelchair user or be automatically operable,
 - c) be equipped with a seat lid or other back support, and
 - d) not have a spring-actuated seat.

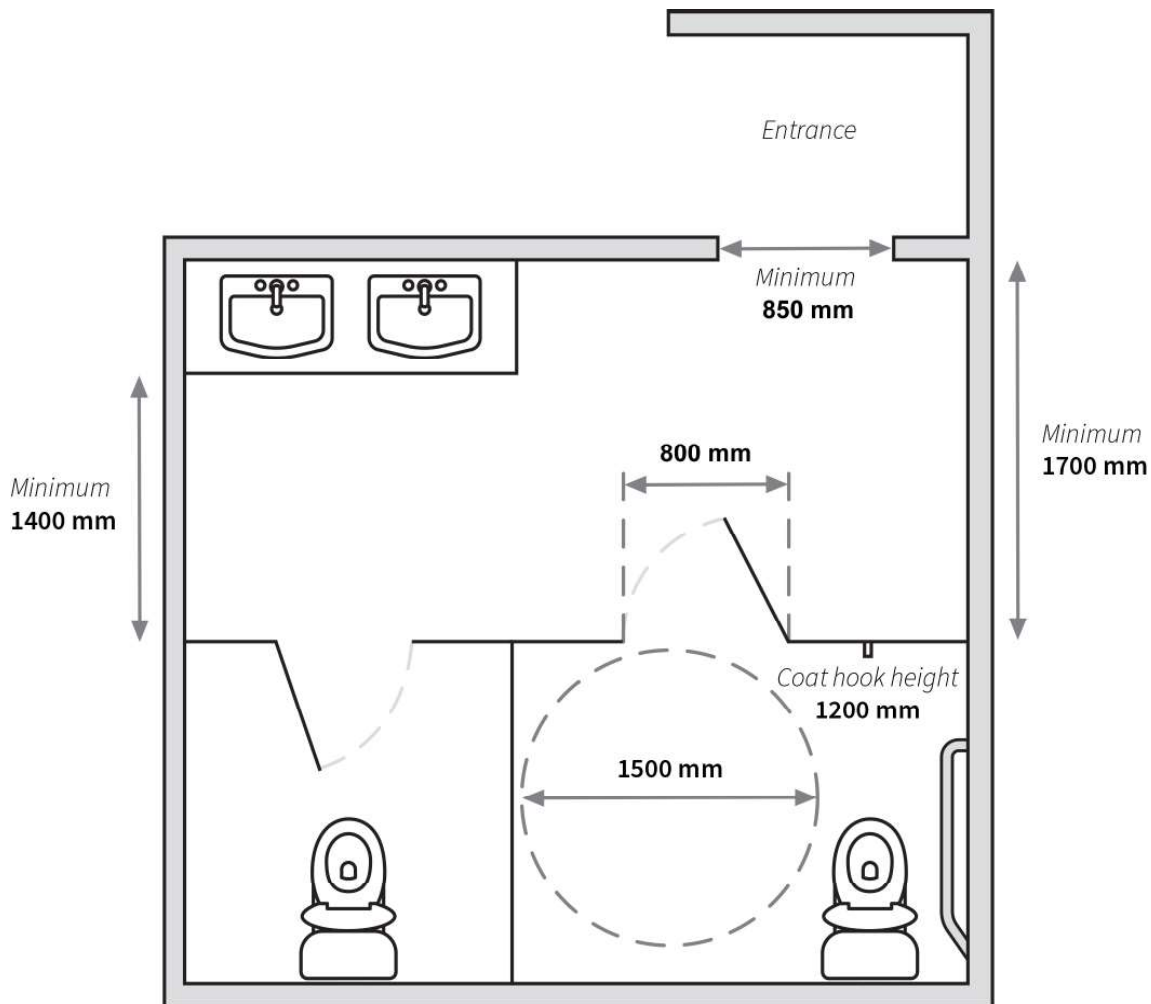

Wall-mounted water closets or floor models with recessed bases are preferable because they provide the least amount of obstruction to a wheelchair user while s/he manoeuvres in front of or beside the toilet. To facilitate transfer from a wheelchair, the toilet seat should be the same height as the wheelchair seat, i.e., between 400 mm and 460 mm from the floor. A properly installed grab bar will aid in a transfer. The grab bar will also benefit those who are elderly and may have difficulty rising from a seated position. These specifications will greatly increase a person's ability to rise, sit, or stand because a grab bar provides stability and safety.

Automatic Flushers for Water Closets and Urinals

In accessible stalls, automatic flushers are preferable to hand-operated flushing mechanisms for both water closets and urinals. Automatic water closet flushers can eliminate the need to lean across the toilet (often the flusher is located on the inaccessible side of the toilet). Hand-operated flushing mechanisms may be difficult for people with limited strength and/or grasp to operate.

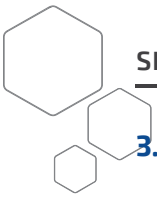

3.8.3.10. Urinals

- 1) If urinals are provided in a barrier-free washroom, at least one urinal shall be
 - a) wall mounted, with the rim located between 488 mm and 512 mm above the floor, or
 - b) floor mounted, with the rim level with the finished floor.
- 2) The urinal described in Sentence (1) shall have
 - a) a clear width of approach of 800 mm centred on the urinal,
 - b) no step in front, and
 - c) installed on each side a vertically mounted grab bar that is not less than 300 mm long, with its centreline 1 000 mm above the floor, and located not more than 380 mm from the centreline of the urinal. (See Appendix A.)

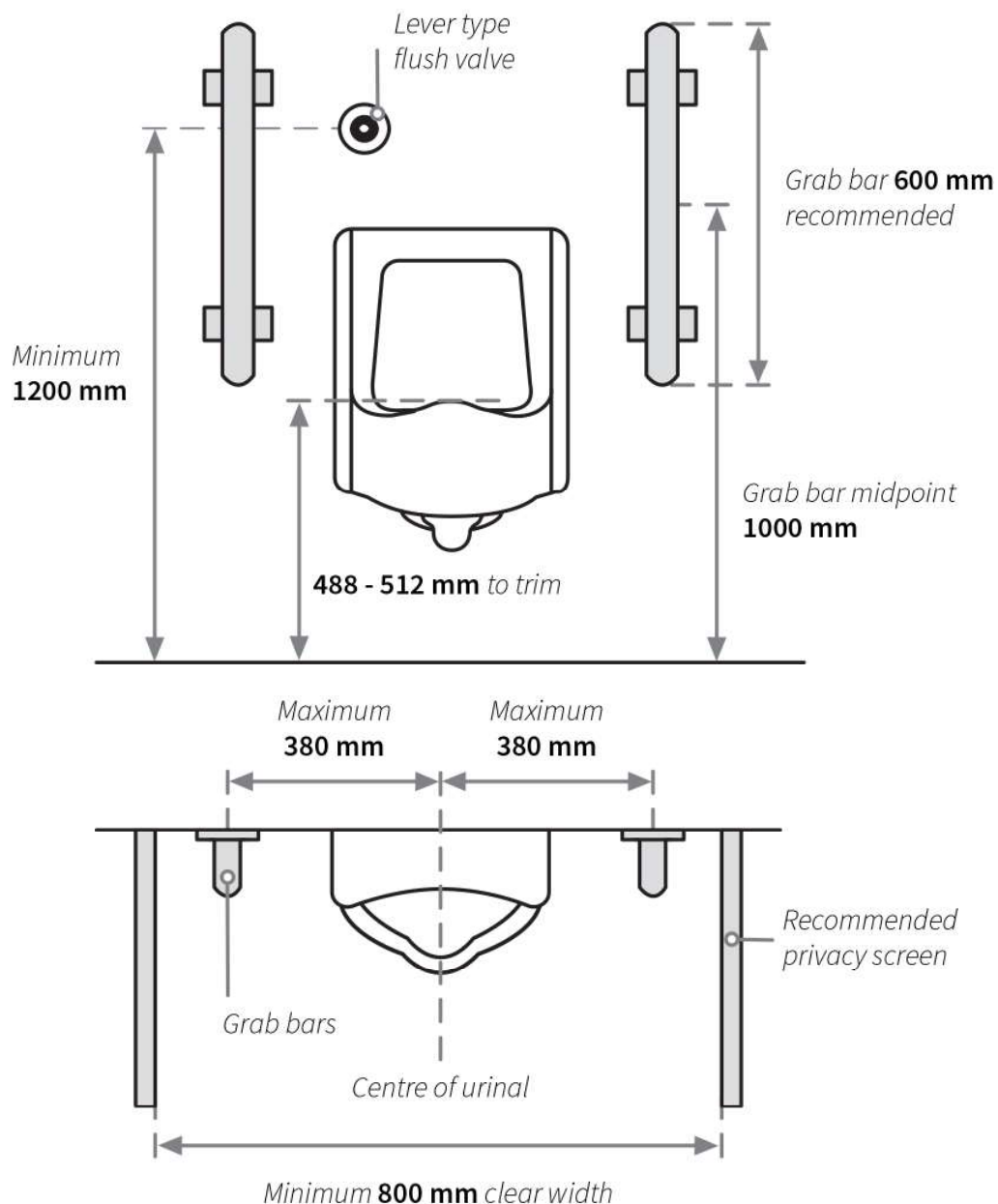

A clear floor space shall be provided in front of a urinal so that the user of a wheelchair can approach the urinal without obstruction. Vertically mounted grab bars on each side of the urinal will allow a person in a wheelchair to pull up to a standing position and/or for stability. A floor-mounted urinal will make it easier to drain appliances, such as catheters. Flush controls should be lever operated or automatic.

Public Shower Facilities

In assembly buildings, such as schools, colleges, and community halls, where individual showers are provided, at least one accessible shower stall and one accessible change cubicle are required for each gender. This will ensure that persons with disabilities and others who use wheelchairs or other mobility aids are accommodated.

3.8.3.13. Showers

- 1) Except as provided in Sentence (2), if showers are provided in a barrier-free path of travel, at least one shower stall shall be barrier-free and shall
 - a) be not less than 1 500 mm wide and 900 mm deep,
 - b) have a clear floor space at the entrance to the shower, not less than 900 mm deep and the same width as the shower, except that fixtures are permitted to project into that space provided they do not restrict access to the shower (see Appendix A),
 - c) have a slip-resistant floor surface,
 - d) have a bevelled threshold not more than 13 mm higher than the finished floor,
 - e) have a hinged seat that is not spring-loaded or a fixed seat that is
 - i) not less than 450 mm wide and 400 mm deep,
 - ii) mounted approximately 450 mm above the floor, and
 - iii) designed to carry a minimum load of 1.3 kN,
 - f) have a horizontal or L-shaped grab bar with a knurled finish grab bar conforming to Clauses 3.8.3.8.(2)(c), (d) and (e) that is
 - i) not less than 900 mm long located on the wall 100 mm from the back of the seat,
 - ii) mounted between 750 mm and 850 mm above the floor, and
 - iii) located on the wall opposite the entrance to the shower so that not less than 300 mm of its length is at one side of the seat, (see Appendix A),
 - g) have a pressure-equalizing or thermostatic-mixing valve controlled by a lever or other device operable with a closed fist from the seated position, located on the side wall between 200 mm and 300 mm in front of the seat,
 - h) have a hand-held shower head with not less than 1 800 mm of flexible hose, located so that it can be reached from the seated position and equipped with a support so that it can operate as a fixed shower head, and
 - i) have fully recessed soap holders which can be reached from the seated position and located on the side wall between 100 mm and 200 mm in front of the seat.

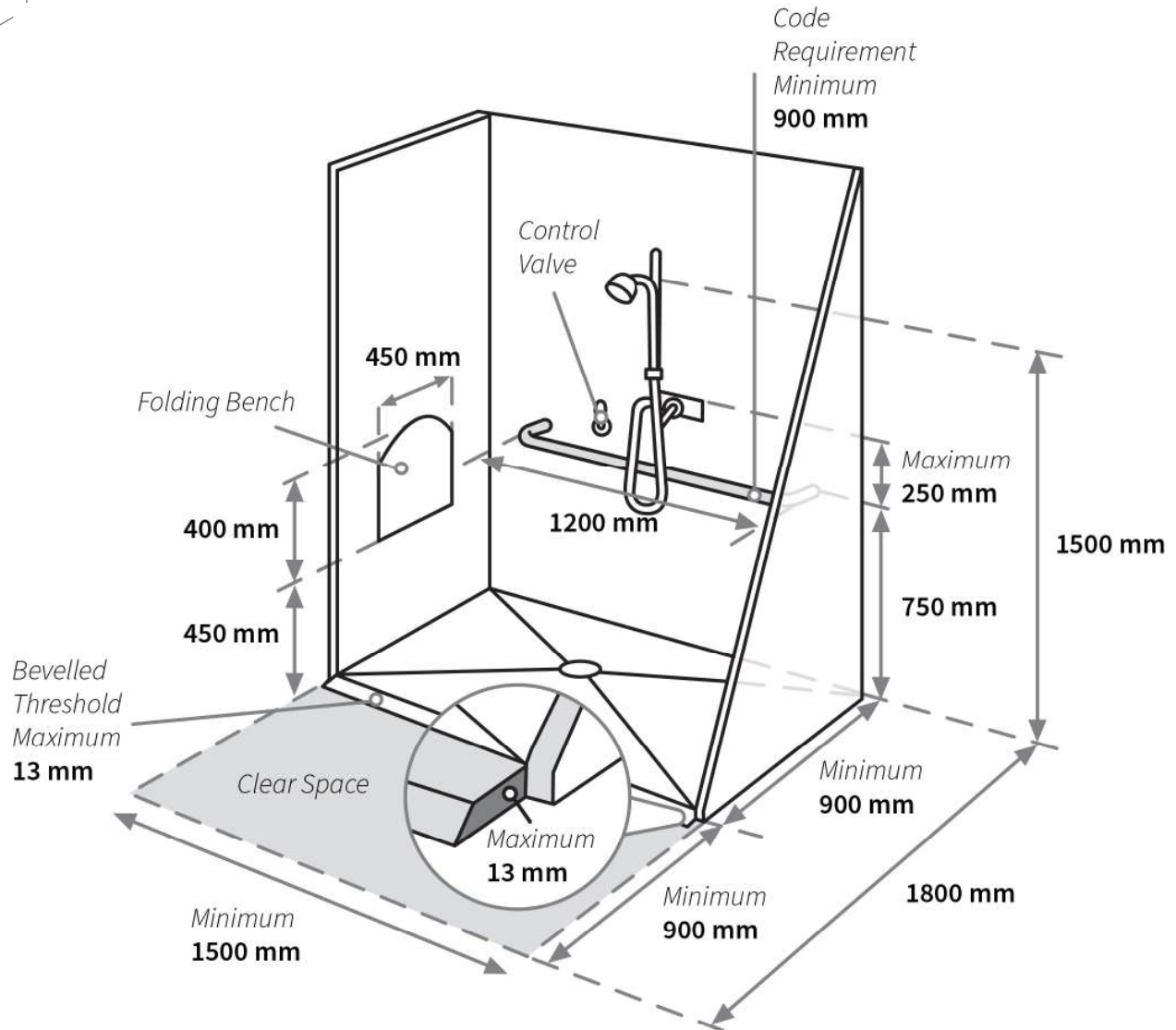

- 2) Sentence (1) does not apply to showers located within
- a suite of care occupancy,
 - a suite of residential occupancy,
 - an industrial occupancy,
 - a business and personal services occupancy where the showers are not required for provision of hygienic services related to the business, or
 - a mercantile occupancy.

The inside measurements of a wheelchair-accessible shower stall shall be a minimum of 1500 mm in length and a minimum of 900 mm in depth with a slip-resistant floor finish, and shall have a bevelled threshold of not more than 13 mm. The handheld shower head should be located in the centre of the long wall (i.e., 1500 mm) adjacent to the fixed seating. This allows a person in a seated position to reach the handheld shower head and controls, or to use the same shower head as a fixed shower from a seated position.

The inside measurement of a change cubicle should be at least 2 000 mm × 2 000 mm with slip-resistant flooring and equipped with a wall-mounted bench seat (as legs or brackets may interfere with a person's ability to turn easily). Button-style clothing hooks (which are not a hazard to eyes or ears) shall be mounted adjacent to the bench seating.

Clear Space at Entrances to Showers

The clear space at the entrance to a shower should not be encroached upon by fixtures such as wall-hung sinks, fixed benches, island counters, trash receptacles, etc., since the obstruction may restrict movement and access to and from the shower and shower area.

Shower Stalls and Grab Bars

Only one grab bar is required and must be installed on the wall adjacent to the seat in the shower stall. If the grab bar is located on the wall opposite the seat, it cannot be reached safely from a seated position. A grab bar behind the seat will interfere with being seated. It is preferred that a single horizontal continuous grab bar be installed in the shower to provide stability and safety for those who prefer to stand or need assistance to walk to the other end of the shower area. (The seat itself may be used in conjunction with the bar to assist with transfers.)

The shower stall shall be equipped with a hinged seat (an acceptable alternative is a portable shower chair/seat), a grab bar, a pressure-balancing single-lever water control, and a handheld shower head (If vandalism is a problem, the use of a fixed shower head is acceptable, as long as it is located near the seat.)

The shower stall control and the handheld shower head should be situated so that ease of access is provided to the person seated on the shower seat (and preferably on the wall adjacent to the seat).

3.7.2.8. Grab Bar Installation

- 1) Grab bars that are installed shall resist a load not less than 1.3 kN applied vertically or horizontally.

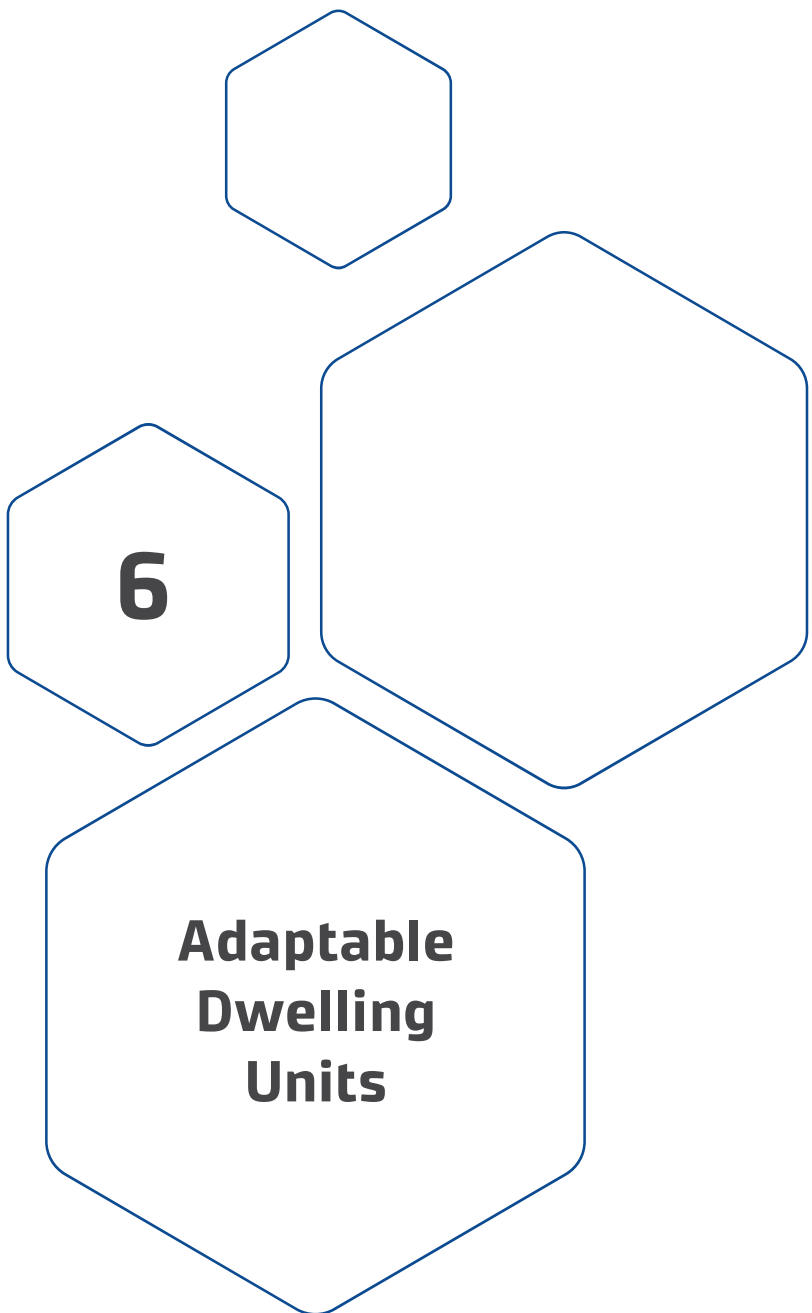



Adaptable Dwelling Units

Adaptable means a dwelling unit that has been designed to allow it to be altered to make the dwelling unit consistent with the principles of barrier-free design. These design features will then allow the space that is to be altered to become fully barrier-free with minimal renovations and cost at a later date.

There must be a certain amount of flexibility incorporated into the dwelling units at the time of construction. As an example, if a dwelling unit is inhabited by an able-bodied person as well as a person who uses a wheelchair, the heights at which the kitchen counters are to be installed become an issue. Flexibility must allow the height of different work stations to be raised or lowered so that the dwelling unit may be converted one way or the other in order to cater to the needs of its current tenants.

3.8.4. Adaptable Dwelling Units

3.8.4.1. Application

- 1) Residential projects of 10 or more units funded in whole or in part by the Government of Alberta are required to provide adaptable dwelling units which could be made to meet barrier-free design principles and shall be provided as follows:
 - a) 1 per 10 dwelling units, based on the total number of units in a project, and
 - b) adaptable dwelling units shall conform to the requirements of this Subsection.

The number of required adaptable dwelling units are based on the total number of units in a project, and not on the number of units designated as affordable for which government funding is provided.

Note: See also 3.8.1.1. Application for more information.

- 1) The requirements of this Section apply to all buildings except
 - a) detached houses, semi-detached houses, houses with a secondary suite, duplexes, triplexes, townhouses, row houses and boarding houses, which are not used in social programs such as group homes, halfway houses and shelters. (See A-1.4.1.2.(1), Secondary Suite, in Appendix A of Division A.)

Government-funded projects apply to all types of dwelling units, including apartment or condominium complexes.

Note: See also 3.8.2.1. Areas Requiring a Barrier-Free Path of Travel for more information.

- 4) Except as provided in Sentence (5), Sentence (1) does not apply to any storey, not more than 600 m² in area, above or below the first storey of a building that does not exceed two storeys in building height.

This Sentence only applies to dwelling units that have a common corridor to multiple private dwelling units such as an apartment or condominium complex that is government funded in part or whole to create affordable housing.

**Note**

This Sentence still applies to all buildings where the public is expected to visit or be employed whether there is Government funding or not.

3.8.4.2. General Accessibility

- 1) At least one entrance serving an adaptable dwelling unit, including walkways leading to the entrance from a public thoroughfare and from on-site parking areas, shall be barrier-free. (See also Article 3.8.3.12. for common entrances to buildings and Article 3.8.2.2. for parking stalls.)
- 2) A barrier-free path of travel shall be provided between the interior living space of the dwelling unit and any ancillary space serving it, including the garage, balcony or deck.
- 3) Entryways, kitchens, washrooms, laundry rooms and other areas of a dwelling unit shall be designed with an unobstructed turning diameter of not less than 1 500 mm.
- 4) Window shall
 - a) be equipped with opening devices located not more than 60 mm above the window sill and of a design that does not require tight grasping, pinching or twisting of the wrist as the only means of operation, and
 - b) be located so that the sill is not more than 865 mm above the floor level
- 5) Controls for the operation of building services or safety devices, including electrical switches, electrical panels, thermostats and intercom switches, shall be mounted between 400 mm and 1 200 mm above the finished floor.
- 6) Electrical outlets shall be mounted between 400 mm and 1 200 mm above the finished floor level.
- 7) Every doorway into rooms within the dwelling unit shall have a clear width not less than 850 mm when the door is in the open position.
- 8) A doorway referred to in Sentence (7) or present in the barrier-free path of travel referred to in Sentences (1) and (2) shall conform to Sentences 3.8.3.3.(4) and (10).
- 9) Structural support shall be provided in at least one bedroom and one washroom to accommodate a ceiling track lift.
- 10) Door and window frames and baseboards shall be contrasting in colour to doors, walls and floors.

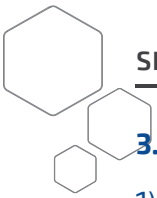

3.8.4.3. Bathrooms

- 1) An adaptable dwelling unit shall be provided with a bathroom containing either a barrier-free shower or bathtub, in accordance with the following:
 - a) where there is an even number of adaptable dwelling units required, 50% of the dwelling units shall have a bathroom containing a barrier-free shower, and the remaining 50% shall have a bathroom containing a barrier-free bathtub, and
 - b) where there is an odd number of adaptable dwelling units required, the number of dwelling units with a bathroom containing a barrier-free shower shall exceed the number of dwelling units with a bathroom containing a barrier-free bathtub by 1.
- 2) The barrier-free bathroom referred to in Sentence (1) shall have the
 - a) shower conform to Clauses 3.8.3.13.(1)(a), (b), (c), (d) and (g) where a shower is provided, and
 - b) bathtub conform to Clauses 3.7.2.9.(1)(a) and (d) and Clause 3.8.3.17.(1)(a) where a bathtub is provided.
- 3) The bathroom referred to in Sentence (1) shall be provided with a lavatory conforming to Clauses 3.8.3.11.(1)(a) to (d).
- 4) The bathroom referred to in Sentence (1) shall be provided with a water closet conforming to Sentence 3.8.3.9.(1) and Clause 3.8.3.12.(1)(d).
- 5) The bathroom referred to in Sentence (1) shall be designed to allow for the installation of grab bars conforming to
 - a) Sentence 3.8.3.8.(2) to serve the water closet,
 - b) Clause 3.8.3.13.(1)(f) to serve the shower where one is provided, and
 - c) Clause 3.7.2.9.(1)(c) to serve the bathtub where one is provided.

3.8.4.4. Kitchens

- 1) Every kitchen counter shall have at least one barrier-free section not less than 760 mm long centred over a knee space conforming to Sentence (3).
- 2) The top surface of the barrier-free section referred to in Sentence (1) shall be not more than 865 mm above the finished floor.
- 3) The knee space beneath the barrier-free section referred to in Sentence (1) shall be not less than
 - a) 760 mm wide,
 - b) 685 mm high, and
 - c) 485 mm deep.
- 4) Counters intended for the installation of a kitchen sink or a cooktop shall be provided with a means of adjusting their height so that the counter surface is
 - a) not less than 710 mm above the finished floor level, and
 - b) not more than the height of the adjacent counter surface.

- 5) The kitchen sink or cooktop referred to in Sentence (4) shall be provided with a clearance beneath the sink or cooktop of not less than
 - a) 760 mm wide,
 - b) 685 mm high at a point 205 mm back from the front edge, and
 - c) 230 mm high over the distance from a point 280 mm to a point 430 mm back from the front edge.
- 6) Overhead kitchen cabinets shall be provided with a means of adjusting their height by not less than 500 mm, provided the minimum clearances for cooktops specified in Subsection 9.10.22. are not reduced at the lowered height.

Care Facilities, Assisted Living and Seniors Housing

Environments that are specifically designed for adults requiring or may require assistance in the activities of daily living should be designed with barrier-free and/or adaptive requirements as prescribed in the Alberta Building Code or this Guide. This would ensure a satisfactory quality of life. However, a few requirements may not fully meet with the needs of the residents or staff.

Other things to consider:

- Raised dishwasher
- Wall oven with a side swing door plus a pull-out shelf below to rest contents
- Vertical grab bar(s) outside the shower
- Horizontal grab bar below the controls in the shower
- Shelf in the shower for shampoo, etc.
- Varying heights for bar fridge
- More than 1 elevator, if applicable
- Power-assist door openers in individual units

Acceptable alternatives for the bathroom within individual units:

- Barrier-free showers for the majority or all of the dwelling units, as long as there are separate bathing rooms with bathtubs
- Portable shower chairs in lieu of hinged seating (permanent)

For further information, contact the Barrier-Free Administrator at Alberta Municipal Affairs.

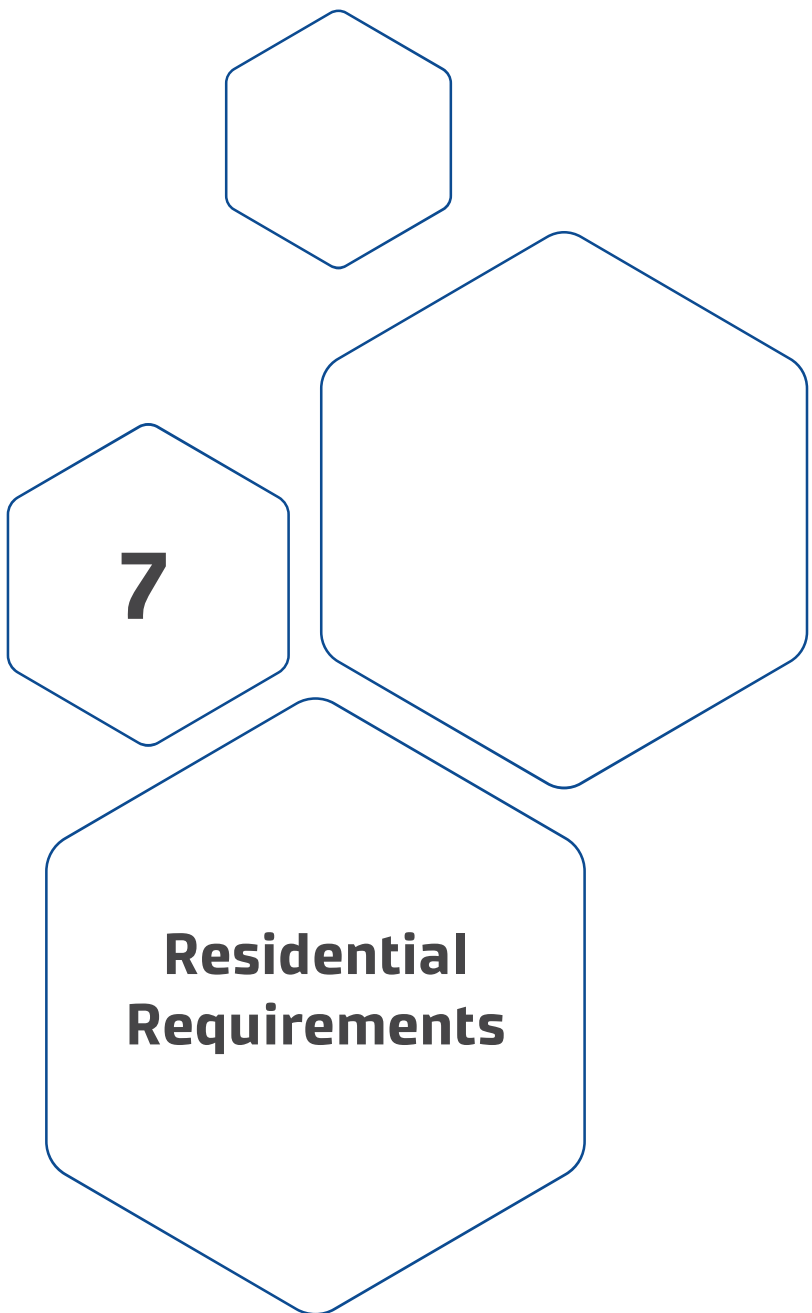



Residential Requirements

Residential Requirements

Universal design is an approach to the design of environments (and products) so that they may be usable by as many people as possible and to the greatest extent possible without the need for adaptation by the user or the need for specialized design. As life expectancy rises and modern medicine has increased the survival rates of those with significant injuries, illnesses and birth defects, there is an increasing need for homes that will house more than one type of user.

The inclusive approach of universal design recognizes the need for function and aesthetics that have appeal to the wide range of consumers.

In order to achieve this, universal design is based on the following seven principles (see Appendix 1):

- equitable use
- flexibility in use
- simple and intuitive in use
- perceptible information
- tolerance for error
- low physical effort
- size and space for approach and use

Inclusion is a sense of belonging, where people can feel respected and valued for who they are. When a community can make this commitment to its members, the community will have greater success because it will benefit from the participation and resources of all its citizens.

Residential Design

The accessibility requirements of the ABC deal primarily with public buildings, and set standards for a wide range of abilities. Barrier-free design for residential application is most often personalized in accordance with one's limitations and lifestyle. Over time, special features are often designed and modified on-site as determined by what an individual can do and has learned to do. To design for accessibility in existing homes usually involves costly renovations and time to complete the project, and may involve some minor inconveniences to the occupant.

The following general design standards are provided as guidelines that will accommodate most disabilities.

Overall Design Elements

There are some design elements that should be incorporated throughout the entire dwelling unit to ensure that accessibility is in place before adaptability can occur:

- Zero or ground level threshold.
- 1.5 m turning diameter in all areas of the unit, including entry and laundry areas.
- Electrical outlets should be no lower than 600 mm when measured from the centre line of the plate to the finished floor.
- Light switches should be mounted between 1 200 mm - 1 400 mm when measured from the centre line of the plate to the finished floor.
- Controls, like thermostats should be mounted at 1 400 mm when measured from the centre line of the plate to the finished floor.
- Colour contrast between the door trim, door and wall.
- Effective tactile-differentiation between living areas for wayfinding and safety.
- Lever-handled hardware on all doors that latch.

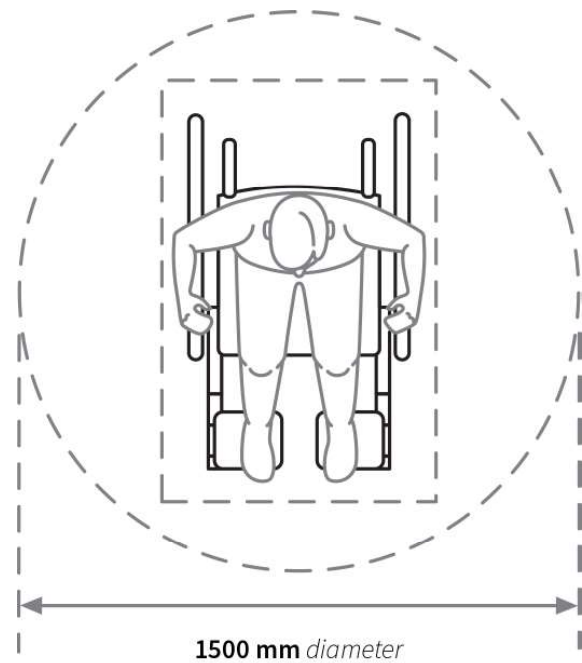

Entrances

In new construction, entrances should be at grade to provide a seamless path of travel into the dwelling unit. This means that exterior doorways should be wide enough (at least 850 mm clear opening) to allow a person in a wheelchair or using another mobility device to enter with ease.

In older properties, stairs present the single greatest barrier. The first design solution is to alter the landscape by raising the land to provide a gradual and seamless path of travel to the entrance. However, the majority of entrances in homes are too high to accomplish this, so an alternative is to install a ramp or lift to create a barrier-free path of travel.

The length of a ramp, without a landing, should not exceed 9 m. A ramp of 9 m in length will elevate the user 750 mm. It would be reasonable to consider a rise of 750 mm for ramping, and the use of a lift for a rise over 750 mm. This general guideline would help to ensure safety of users as well as conserve real estate (if that is desired).

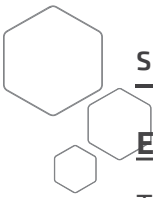

Exterior Doors

The ability to view the exterior entrance from the inside is necessary from a safety (crime prevention) perspective. Windows with lowered sills allow a person in a wheelchair (or a child) to view the exterior before opening the door to callers. If this is not possible, it is recommended that the door be changed to include a glass insert or a door security viewer, which should be located 1 150 mm from the floor.

Interior Doorways and Hallways

The relationship of a hallway to a doorway is critical. Narrow hallways impede the ability of a person who uses a wheelchair or other mobility device, especially when s/he needs to turn a 90° corner. A minimum width of 1 200 mm is needed for movement of a person who uses a wheelchair.

Interior doorways are required to have a minimum doorway width of 850 mm to accommodate wheelchairs, including larger power wheelchairs and scooters.



Note

When designing accommodations intended for the bariatric population, doorways (both exterior and interior) should have a clear width opening of 1100 mm - 1200 mm, and hallways should be 1200 mm - 1500 mm in width to allow for ease of movement.

The use of lever handles is preferred on doors that latch. Pocket doors can be difficult to pull or push. Making the doorway wider and adding a D-handle to a pocket door will allow for easier access.

Residential bathrooms are normally too small to allow a door to swing inward and therefore doors to such rooms should swing out, usually into a corridor. However, with new construction, it is possible to design the bathroom so that the door will swing inward.

Windows

Windows throughout a residence are at or above the eye level of a person in a wheelchair or of a child. The designer/contractor should make the window sill in living and dining rooms no higher than 600 mm. This enables a person using a wheelchair to see the exterior comfortably for both enjoyment and safety. For bedroom, bathroom and other windows (the kitchen may be an exception), the window sills should be no higher than 750 mm when measured from the finished floor. Windows should be easy to open and close, and their controls should be placed in an area 750 mm to 1 000 mm when measured from the floor.

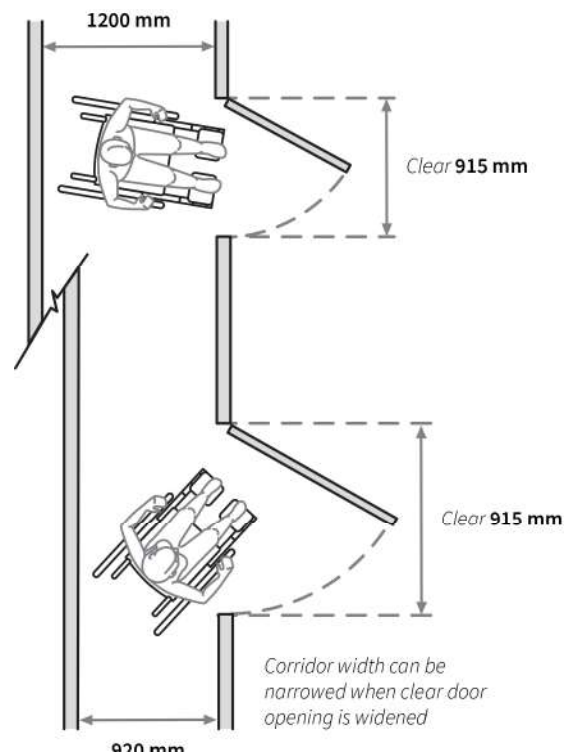

Lowered window sills and easy-to-operate mechanisms will also provide an alternate evacuation route in an emergency.

Kitchens

Kitchens are complex to design because of the various workstations that need to be considered and made accessible for all users. The following is a list of key design elements that need to be in the kitchen.

Recommended:

- Turning diameter of 1 500 mm or greater.
- Height-adjustable cook top with controls located in front, and a height-adjustable sink with a single lever faucet.
- Counter tops with at least two counter heights (915 mm and 760 mm) and with knee space beneath.
- Additional counter space for appliances, such as a microwave.
- A pull-out work surface.
- Upper cabinets mounted on a track system that will allow for adjustability, and lower cabinets with drawers on full-extension glides and D-handles.
- A wall oven with a side-swing door, and a pull-out shelf below the oven on full-extension glides.
- At least two electrical outlets mounted on the lower cabinetry.

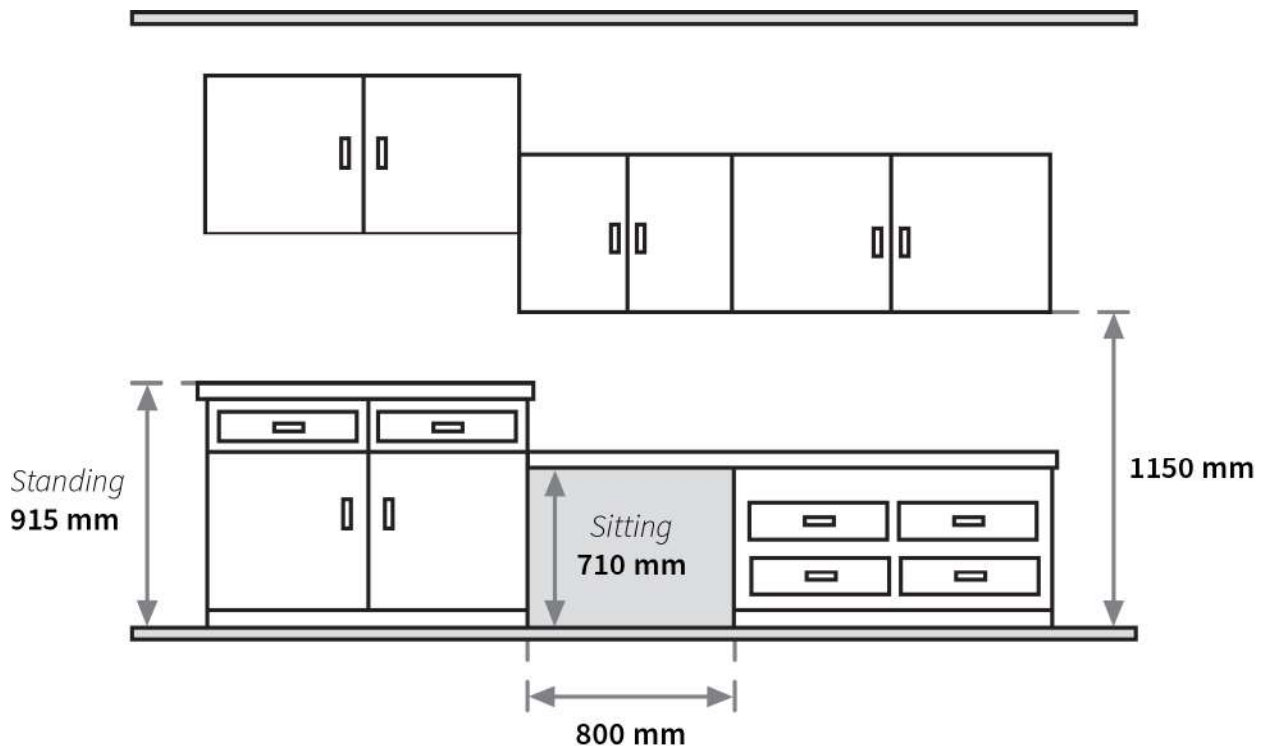

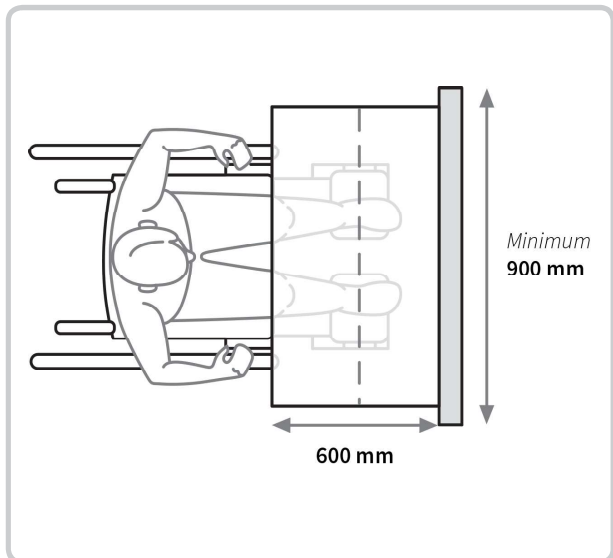
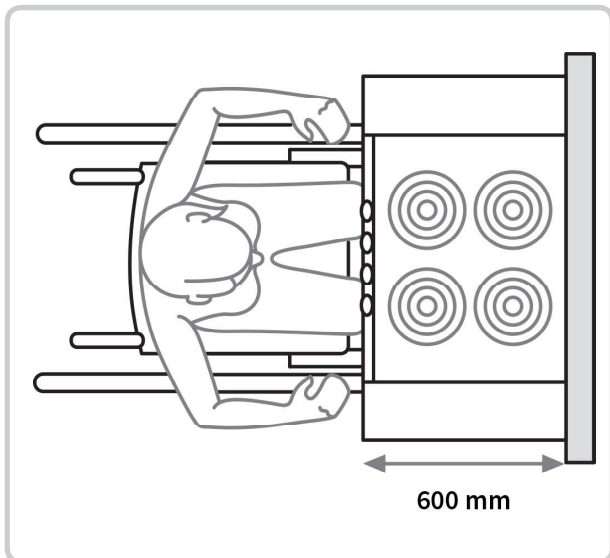
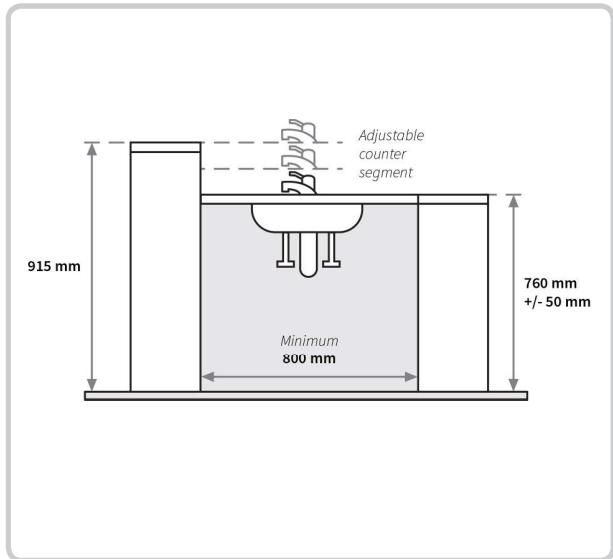
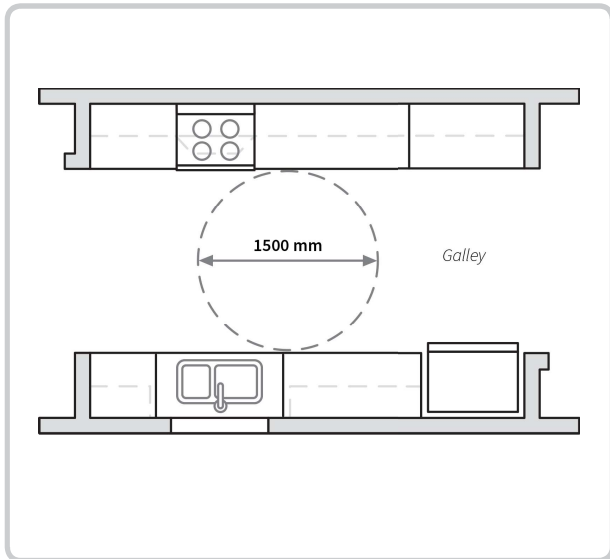
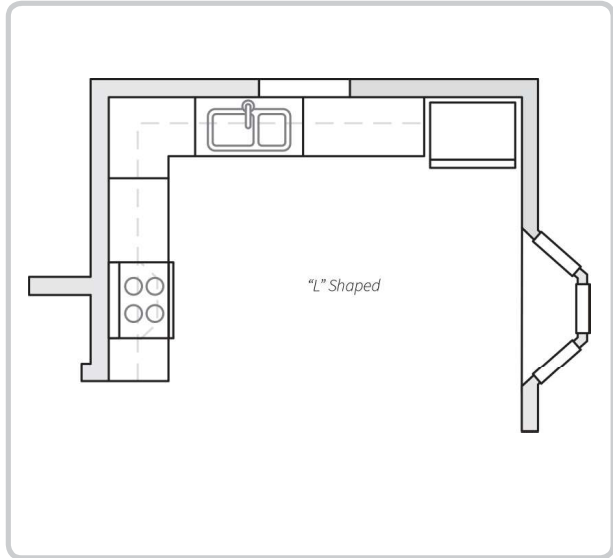
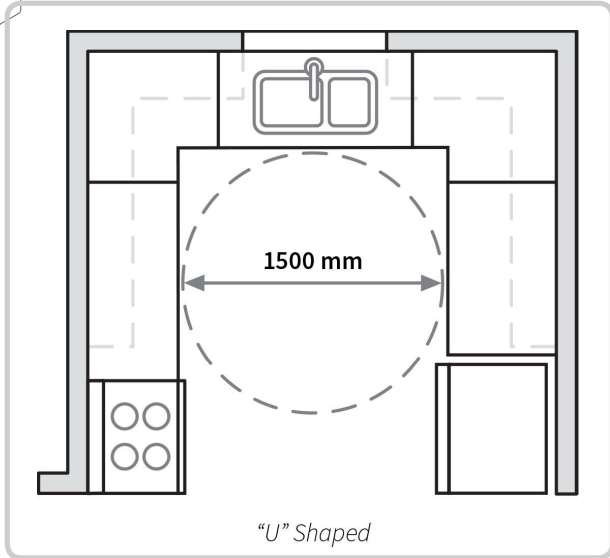

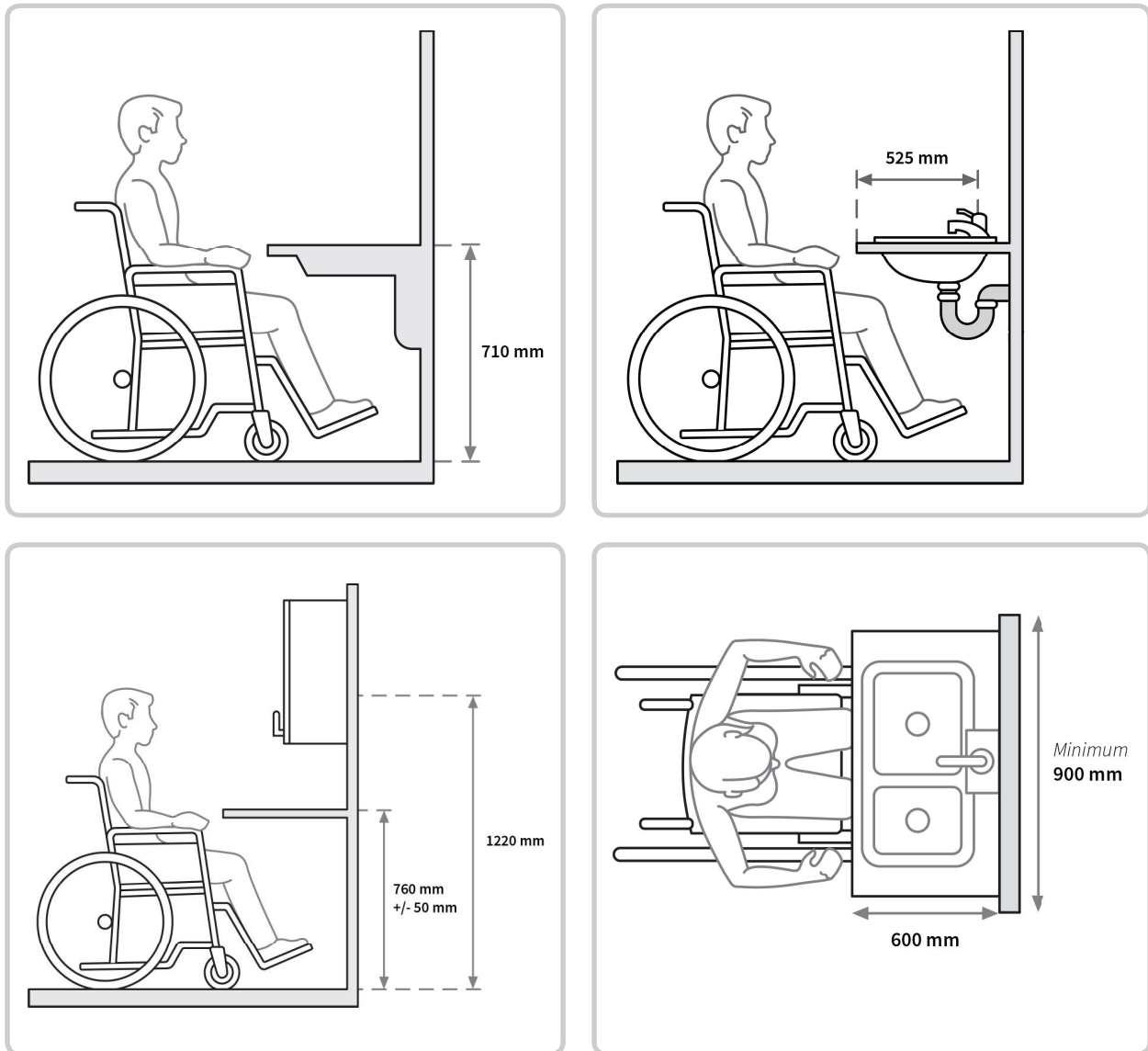

Select appliances that will be suitable to the primary occupants, whether they are persons with disabilities or seniors, will appreciate the thought given to creating an attractive and accessible kitchen. A free-standing microwave oven and a refrigerator with a bottom freezer (or a side-by-side) are good options.

Bathrooms

The barrier-free code requirements in the ABC are specifically for the design of public washrooms. However, many of the height and distance measurements are valid for use in a residential dwelling unit.

Recommended:

- Turning diameter of 1 500 mm or greater.
- Shallow sinks with knee space beneath; exposed plumbing must be insulated to prevent burns.



SECTION 7

- Single lever faucet control for the sink, shower and/or bathtub.
- 1 500 x 1 500 mm shower with no lip, and/or a bathtub (see 3.8.3.17. Bathtubs; 3.8.3.13. Showers).
- Grab bars for the toilet, shower and bathtub.
- A transfer space (for those who use wheelchairs) of 900 - 1 000 mm located beside the toilet.

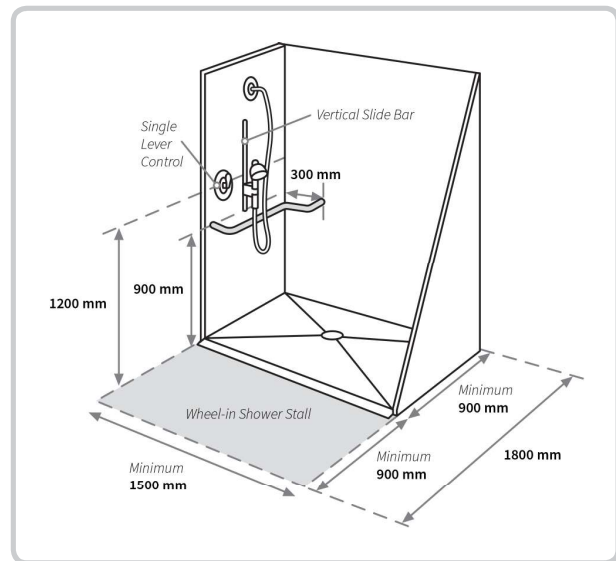
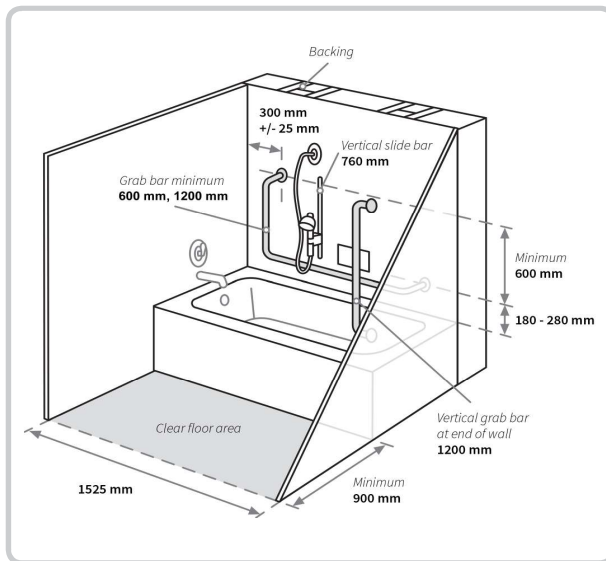
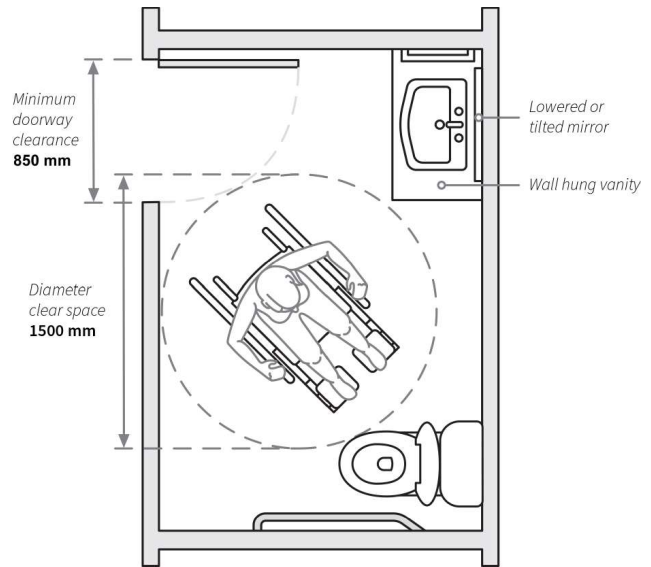

Note

The powder room or 2-piece shall follow the same design considerations that are required for a full bath, eg., turning diameter that it may be suitable for visitability or conversion to a full bath (with a shower).

With careful planning and positioning of fixtures, an existing slightly larger conventional washroom can be made accessible.

Designers should plan all bathrooms with people using larger wheelchairs or scooters, and those with visual disabilities, in mind. The functional placement of fixtures must be considered when the goal is to provide safe and effective access.

3.8.3.17. Bathtubs

- 1) If a bathtub is installed in a suite of residential occupancy required to be barrier-free, it shall
 - a) be located in a room complying with the dimensions stated in Sentence 3.8.3.12.(1),
 - b) conform to Article 3.7.2.9.,
 - c) be equipped with a hand-held shower head mounted on a vertical slide bar not less than 760 mm long and with the bottom of the slide bar at a height not less than 1 200 mm above the floor, and controls and flexible hose conforming to Article 3.8.3.13.

**Note**

Ensure that bathtubs have slip-resistant surfaces. If feasible, add a non-slip, waterproof seating area a minimum of 400 mm deep and located at the end of the bathtub to provide easier and safer transfers in and out of the tub.

In the new construction of a hotel or motel, or the renovation of existing units, the bathtubs shall conform to Sentence 3.7.2.9.(1). Grab bars must be installed in every bathing unit, whether designated accessible or not. The intent of this Code is to ensure that all guests are provided with an added measure of safety. This also provides the owner with more options to accommodate guests who may require moderate assistance with bathing.

3.7.2.9. Bathtubs

- 1) Where a bathtub is installed in a hotel or a motel, it shall
 - a) notwithstanding the presence of a water closet or a lavatory, have a clear floor space at least 900 mm wide along its length,
 - b) have faucets that conform to Clause 3.7.2.3.(4)(b),
 - c) have grab bars that
 - i) conform to Sentence 3.7.2.8.(1),
 - ii) are 1 200 mm long located vertically at the end of the bathtub that is adjacent to the clear floor space, with the lower end between 180 mm and 280 mm above the bathtub rim, and
 - iii) are 1 200 mm long located horizontally along the length of the bathtub at 180 mm to 280 mm above the bathtub rim, and
 - d) be open along its length with no tracks mounted on the bathtub rim.

**Note**

A hotel or motel suite must have a barrier-free path of travel to its entry. This includes wider doorways into the suite and wider doorways to the bathrooms within. (It is unreasonable to expect that visitors who use a wheelchair or other mobility device leave that suite to use an accessible washroom in another part of the building.) (See Sentence 3.8.2.1.(1) Areas Requiring a Barrier-Free Path of Travel.)

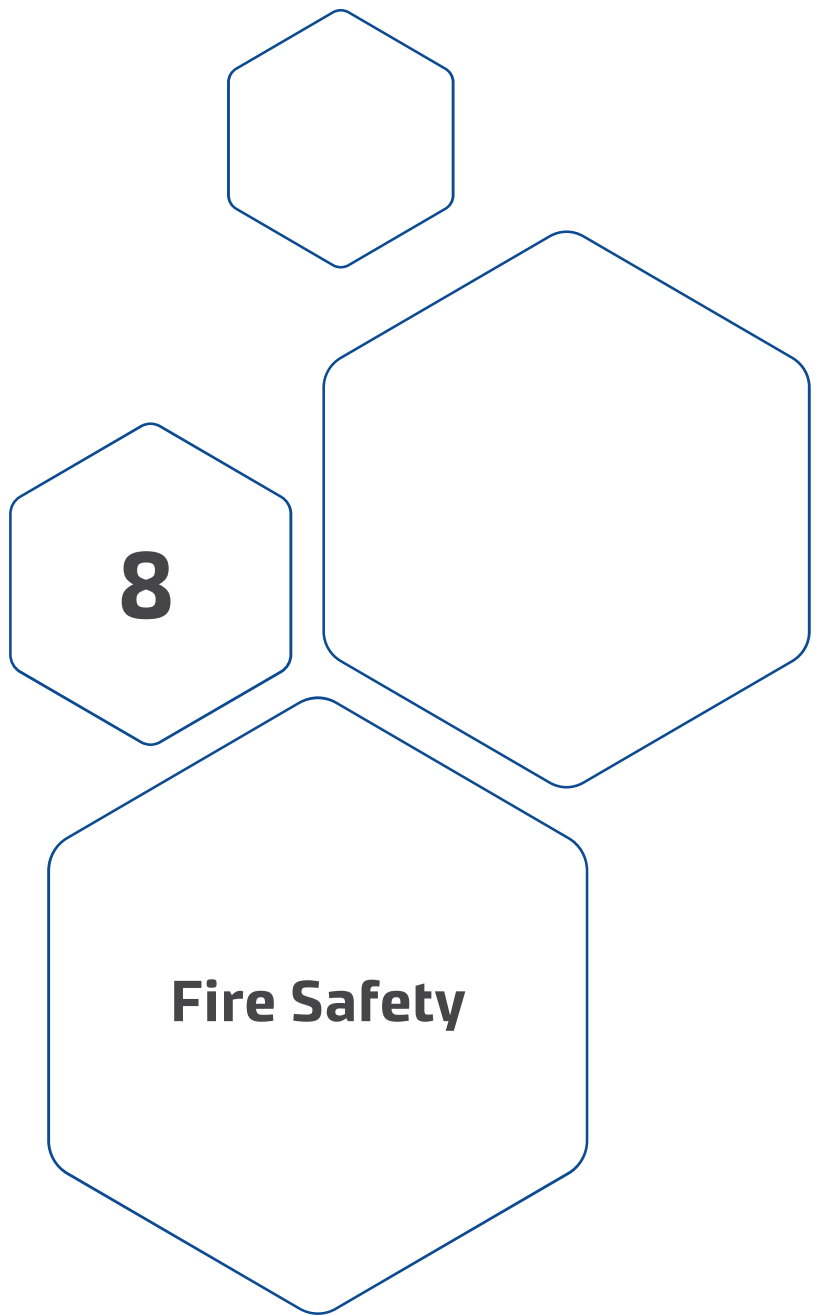

8

Fire Safety



Fire Safety

Fire safety requirements are in place to alert and protect property users by minimizing risks to health and safety in a built environment.

Protection on Floor Areas with a Barrier-Free Path of Travel

3.3.1.7. Protection on Floor Areas with a Barrier-Free Path of Travel

- 1) Every floor area above or below the first storey that is not sprinklered throughout and that has a barrier-free path of travel shall
 - a) be served by an elevator
 - i) conforming to Sentences 3.2.6.5.(6) to (8),
 - ii) protected against fire in conformance with Clauses 3.2.6.5.(5)(b) or (c), and
 - iii) in a building over 3 storeys in building height, protected against smoke movement so that the hoistway will not contain more than 1% by volume of contaminated air from a fire floor during a period of 2 h after the start of a fire, assuming an outdoor temperature equal to the January design temperature on a 2.5% basis determined in conformance with Subsection 1.1.3.,
 - b) be divided into at least 2 zones by fire separations conforming to Sentences (2), (3) and (4) so that
 - i) persons with physical disabilities can be accommodated in each zone, and
 - ii) the travel distance from any point in one zone to a doorway leading to another zone shall be not more than the value for travel distance permitted by Sentence 3.4.2.5.(1) for the occupancy classification of the zone,
 - c) in the case of residential occupancies, be provided with balconies conforming to Sentence (5), except on the storey containing the barrier-free entrance required by Article 3.8.1.2.,
 - d) have an exterior exit at ground level, or
 - e) have a ramp leading to ground level.

(See Appendix A.)

- 2) Except as permitted by Sentence (3), the fire separations referred to in Clause (1)(b) shall have a fire-resistance rating not less than 1 h.
- 3) The fire-resistance rating of the fire separations referred to in Clause (1)(b) is permitted to be less than 1 h but not less than 45 min provided the fire-resistance rating required by Subsection 3.2.2. is permitted to be less than 1 h for
 - a) the floor assembly above the floor area, or
 - b) the floor assembly below the floor area, if there is no floor assembly above.

- 4) A door acting as a closure in a fire separation referred to in Clause (1)(b) shall be weatherstripped or otherwise designed and installed to retard the passage of smoke. (See A-3.3.3.5.(6) in Appendix A.)
- 5) A balcony required by Clause (1)(c) shall
 - a) have direct barrier-free access from the suite or floor area
 - b) be not less than 1.5 m deep from the outside face of the exterior wall to the inside edge of the balcony, and
 - c) provide not less than 1.5 m² of balcony space for each nonambulatory occupant and 0.5 m² for each ambulatory occupant.
- 6) In a barrier-free path of travel, a downward change in elevation shall be signalled by the use of a 600 mm wide tactile warning strip placed 250 mm from the edge and for the full width of a stair, escalator, moving walkway, ramp or platform, and identified using colour and brightness contrast.

**Note**

The above measures are intended to provide temporary places of refuge for persons with disabilities. In all situations, a plan to evacuate persons with disabilities must be developed and approved by the local fire authorities. This is a mandatory requirement as cited in the Alberta Fire Code.

Areas of Refuge**3.3.3.6. Areas of Refuge**

- 1) Compartments containing rooms such as operating rooms, recovery rooms, delivery rooms and intensive care units, from which it is impracticable to move patients in an emergency, shall be
 - a) separated from adjacent spaces by fire separations having a fire-resistance rating not less than 1 h, and
 - b) provided with a mechanical air supply so that during a period of 2 h after the start of a fire in another space, the compartments will not contain more than 1% by volume of contaminated air from the fire area.

3.3.3.7. Contained Use Areas

- 1) A contained use area shall conform to Sentences (2) to (5).
- 2) A contained use area shall be separated from the remainder of the building by a fire separation having a fire-resistance rating not less than 1 h.
- 3) Except as permitted by Sentence (4), a building that includes a contained use area shall be sprinklered throughout.

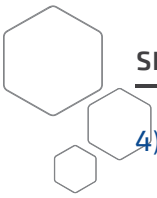

- 4) A contained use area, in a building for which Articles 3.2.2.20. to 3.2.2.90. do not require the installation of an automatic sprinkler system, is not required to be sprinklered as required by Sentence (3) provided
 - a) the building is designed so that during a period of 2 h after the start of a fire in the contained use area other fire compartments will not contain more than 1% by volume of contaminated air from the contained use area,
 - b) the building is designed so that during a period of 2 h after the start of a fire in another part of the building the contained use area will not contain more than 1% by volume of contaminated air from the other part of the building,
 - c) all doors are designed to be remotely released in conformance with Sentence 3.3.1.13. (6), and
 - d) the contained use area does not contain any rooms lined with combustibile padding.
- 5) A corridor serving a contained use area shall have no dead-end portion unless the area served by the dead-end portion has a second and separate means of egress.



Note

In buildings without sprinklers, it is necessary to take additional measures to ensure the safety of persons with disabilities and those who may require assistance to exit a burning building.

Three design measures are suggested:

- 1) An elevator meeting CSA-B44-04 Safety Code for Elevators and Escalators should be installed. The electrical system serving the elevator shall be protected against the effects of fire, and a safe zone be created around the elevator doors by means of a vestibule or corridor that is protected by fire resistive construction. This protected elevator is intended to be used by firefighters to evacuate persons with disabilities. It is not intended that this elevator be used without the assistance of firefighters.
- 2) The floor area should have a safe zone that is separated by fire resistive construction, such as a door that has the ability to retard the passage of smoke between zones, and minimizes the distance of travel for those who need to move to another zone. In office buildings, the distance to a safe zone and exit is 40 m; for all other occupancies, the distance is no greater than 30 m. The size requirement of each safe zone can be created or designed by the number of occupants who may require assistance in an emergency.
- 3) Direct exit with zero grade to the exterior of the building is preferred. However, a ramp leading to the exterior ground level is also acceptable.

9.5.2. Barrier-Free Design

9.5.2.1. General

- 1) Except as provided in Articles 9.5.2.3. and 3.8.1.1., every building shall be designed in conformance with Section 3.8.

9.5.2.2. Protection on Floor Areas with a Barrier-Free Path of Travel

- 1) Where a barrier-free path of travel required in Article 9.5.2.1. is provided to any storey above the first storey, the requirements in Article 3.3.1.7. shall apply.

9.5.2.3. Exception for Apartment Buildings

- 1) Except as provided in Sentence (2), if the building is not equipped with an elevator, the barrier-free path of travel described in Section 3.8. need only be provided on the entrance level of an apartment building.
- 2) The barrier-free path of travel on the entrance level described in Sentence (1) need not be provided where the difference in floor elevation between the entrance level and every dwelling unit exceeds 600 mm.

Fire Alert and Alarm Systems

The primary purpose of fire alarm systems is to warn occupants to evacuate a building by providing the necessary information. An audible signal shall be accompanied with a visual signal to ensure that people who are deaf or hard of hearing and people who are blind receive notification of the alert and/or alarm in an emergency. In addition, the system may include a textual notification appliance to provide further communication for people who are deaf or hard of hearing.

In buildings required to be barrier-free, the audible and visual signals shall be designed and installed to ensure that no harm befalls persons who are deaf or hard of hearing or any others.



Note

The Alberta Fire Code (AFC) 2014 references the National Fire Protection Association (NFPA) Standard 72®-2010 Edition. The NFPA provides important information on good engineering design practices for visual signaling devices and to the placement of visual signals when proximity to the audible signals is considered and/or necessitated.

See: www.nfpa.org-NFPA®72 - 2010 ed. Chapter 18 Notification Appliances

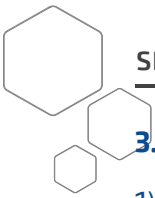

3.2.4.18. Alert and Alarm Signals

- 1) In a 2-stage fire alarm system as described in Sentence 3.2.4.4.(2), the same audible signal devices are permitted to be used to sound the alert signals and the alarm signals.
- 2) If audible signal devices with voice reproduction capabilities are intended for paging and similar voice message use, other than during a fire emergency, they shall be installed so that alert signals and alarm signals take priority over all other signals.
- 3) Audible signal devices forming part of a fire alarm or voice communication system shall not be used for playing music or background noise.

3.2.4.19. Audibility of Alarm Systems

(See Appendix A.)

- 1) Audible signal devices forming part of a fire alarm system shall be installed in a building so that
 - a) alarm signals are clearly audible throughout the floor area, and
 - b) alert signals are clearly audible in continuously staffed locations, and where there are no continuously staffed locations, throughout the floor area. (See Appendix A.)
- 2) The sound pattern of an alarm signal shall conform to the temporal pattern defined in Clause 4.2 of ISO 8201, “Acoustics-Audible emergency evacuation signal.” (See Appendix A.)
- 3) The sound patterns of alert signals shall be significantly different from the temporal patterns of alarm signals. (See Appendix A.)
- 4) The fire alarm signal sound pressure level shall be not more than 110 dBA in any normally occupied area. (See Appendix A.)
- 5) The sound pressure level in a sleeping room from a fire alarm audible signal device shall be not less than 75 dBA in a building of residential or care occupancy when any intervening doors between the device and the sleeping room are closed. (See Appendix A.)
- 6) Except as required by Sentence (5), the sound pressure level from a fire alarm system’s audible signal device within a floor area shall be not less than 10 dBA above the ambient noise level without being less than 65 dBA.
- 7) Except as permitted by Sentence (11), audible signal devices located within a dwelling unit shall include a means for them to be manually silenced for a period of not more than 10 min, after which time the devices shall restore themselves to normal operation. (See Appendix A.)

-
- 8) Audible signal devices within a dwelling unit or a suite of residential or care occupancy shall be connected to the fire alarm system
 - a) in a manner such that a single open circuit at one device will not impair the operation of other audible signal devices on that same circuit that serve the other dwelling units or suites of residential or care occupancy, or
 - b) on separate signal circuits that are not connected to the devices in any other dwelling unit, public corridor or suite of residential or care occupancy. (See Appendix A.)
 - 9) In a building or part thereof classified as a residential or care occupancy,
 - a) separate circuits shall be provided for audible signal devices on each floor area, and
 - b) audible signal devices within dwelling units or suites of residential or care occupancy shall be wired on separate signal circuits from those not within dwelling units or suites of residential or care occupancy. (See A-3.2.4.19.(8) in Appendix A.)
 - 10) Audible signal devices shall be installed in a service space referred to in Sentence 3.2.1.1.(8) and shall be connected to the fire alarm system.
 - 11) Audible signal devices within dwelling units that are wired on separate signal circuits need not include a means for silencing as required by Sentence (7) provided the fire alarm system includes a provision for an automatic signal silence within dwelling units, where
 - a) the automatic signal silence cannot occur within the first 60 s of operation or within the zone of initiation,
 - b) a subsequent alarm elsewhere in the building will reactuate the silence audible signal devices within dwelling units,
 - c) after a period of not more than 10 min, the silenced audible signal devices will be restored to continuous audible signal if the alarm is not acknowledged, and
 - d) the voice communication system referred to in Article 3.2.4.22. has a provision to override the automatic signal silence to allow the transmission of voice messages through silenced audible signal device circuits that serve the dwelling units. (See A-3.2.4.19.(7) in Appendix A.)
 - 12) If a 2-stage fire alarm system has been installed with an automatic signal silence as described in Sentence (11), the system shall be designed so that any silenced audible signal devices serving dwelling units are reactuated whenever an alarm signal is required to be transmitted as part of the second stage. (See A-3.2.4.19.(7) in Appendix A.)

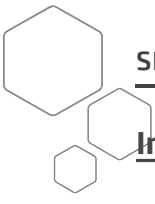

Installation of Alarms and Lights

Fire alarms shall be audible in all areas of a building, including service areas such as mechanical penthouses and interstitial spaces. Walls separating suites are designed and constructed for better sound attenuation. To compensate for the intervening walls, designers should install alarms within individual suites rather than increasing the size of the alarm bells (or ineffective alarm frequencies) in corridors.

All audible sounds must be accompanied with visual cues to ensure that the needs or access/safety issues of all users are addressed.

3.2.4.20. Visual Signals

(See Appendix A.)

- 1) Visual signal devices shall be installed in addition to audible signal devices in buildings required to have a fire alarm system and shall conform to CAN/ULC-S526, “Visible Signal Devices for Fire Alarm Systems Including Accessories.”
- 2) Visual signal devices required by Sentence (1) shall be installed so that the signal from at least one device is visible within a suite in which they are installed.

For further information on the interpretation of visual signals, please see the STANDATA 14-BCI-002.

Hospitality Industry

Sentence (5) says that the audible signal shall be not less than 75 dBA; however, it is the recommendation of this Guide that the audible signal be not less than 85 dB. A higher decibel is not always effective at waking people who are deaf, or sound sleepers. A lower frequency is determined to be more effective where safety is an issue.

Suites designated for use by persons who are deaf, hard of hearing or deaf-blind should also be equipped with visual signalling devices and a vibration device for the bed so that it will vibrate, helping to wake a person who is asleep when the alarm is activated. This single unit system usually fits under a pillow, and is also connected to a clock or telephone, which acts as an additional alert.

Apartment and Condominium Units

Designers should install alarms within individual suites rather than increasing the size of the alarm bells (or adding ineffective alarm frequencies) in corridors. A variety of reasons for not being easily wakened must be considered, e.g., sound sleeper, medications, ear plugs, eye masks, or hearing loss.

Textual visible devices are used primarily to communicate information rather than act as an alarm.

See www.nfpa.org-NFPA®72-2010 ed. for examples of textual visible appliances including annunciators, panel displays (LED and LCD), CRTs, screens and signs.

Manual Fire Alarm Pull Stations

It is important that manual fire-alarm pull stations be accessible to everyone since the purpose of an alarm is to notify all occupants that there may be, or is, danger of fire. In some buildings (see building classifications) the activation of an alarm will automatically transmit its signal to the fire department. Other buildings (see building classifications) will require the occupant to contact the fire department (or call 911) when the alarm has been activated.

3.8.1.5. Controls

- 1) Except as required by Sentence 3.5.2.1.(3) and Article 3.8.3.5. for elevators and platform-equipped passenger-elevating devices, controls for the operation of building services or safety devices, including electrical switches, thermostats and intercom switches, that are intended to be operated by the occupant and are located in or adjacent to a barrier-free path of travel shall be accessible to a person in a wheelchair, operable with one hand, and mounted between 400 mm and 1 200 mm above the floor.

3.2.4.17. Manual Stations

- 1) Except as permitted by Sentences (2) and (3), where a fire alarm system is installed, a manual station shall be installed in every floor area near
 - a) every principal entrance to the building, and
 - b) every exit.(See Appendix A.)
- 2) In a building that is sprinklered throughout, a manual station is not required at an exterior egress doorway from a suite that does not lead to an interior shared means of egress in a hotel or motel not more than 3 storeys in building height, provided each suite is served by an exterior exit facility leading directly to ground level.
- 3) In a building that is sprinklered throughout, a manual station is not required at an exterior egress doorway from a dwelling unit that does not lead to an interior shared means of egress in a building not more than 3 storeys in building height containing only dwelling units, provided each dwelling unit is served by an exterior exit facility leading directly to ground level.
- 4) In a building referred to in Sentences (2) or (3), manual stations shall be installed near doorways leading from shared interior corridors to the exterior.
- 5) Where a fire alarm system is installed, a manually operated fire alarm station shall be installed on the roof at each exit from a helicopter landing area.

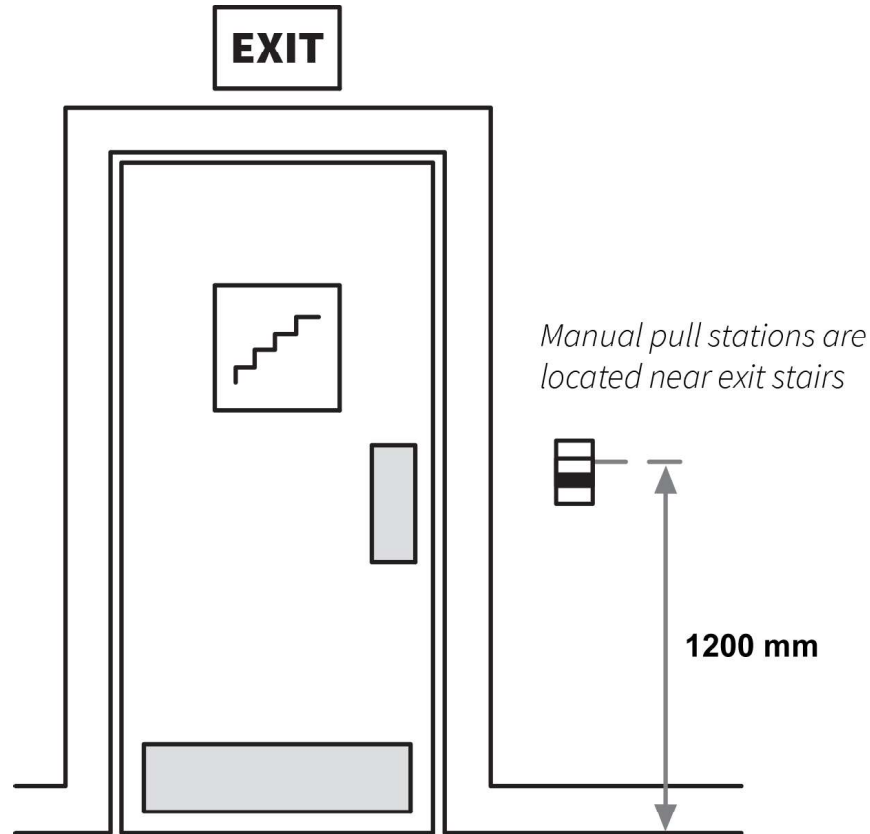

Tactile Warning Signals

3.3.1.7. Protection on Floor Areas with a Barrier-Free Path of Travel

- 1) In a barrier-free path of travel, a downward change in elevation shall be signalled by the use of a 600 mm wide tactile warning strip placed 250 mm from the edge and for the full width of a stair, escalator, moving walkway, ramp or platform and identified using colour and brightness contrast.

Embossed surfaces are used to warn people who are visually disabled of a change in condition. People using a cane rely on changes to surfaces for clues (the change in sound and/or “feel” when tapped or tread on) regarding their environment. A change in flooring material or a grid of truncated domes placed 60 mm apart and forming a floor texture can serve as a tactile warning strip.

To assist persons with limited vision and those who are blind, tactile warning strips in contrasting colours shall be used at the top of escalators, ramps, moving walkways, stairways, and at the edge of platforms not served by handrails or guards, as would be the case with transit stations. The required tactile warning strip shall begin 850 mm back from the edge in question and for its full width. It should feel and/or sound noticeably different when walked on, and be in a contrasting colour to the surrounding flooring. It should not cause a person to stumble.

Stairwells that are properly identified with tactile signals can also serve as a warning of a change in direction.

Grooves parallel to the direction of travel within the curb cut are often used to indicate a street.

See www.cnib.ca-Clearing Paths for more information on tactile warning.

Floor Numbering

3.4.6.19. Floor Numbering

- 1) Arabic numerals indicating the assigned floor number shall
 - a) be mounted permanently on the stair side of the wall at the latch side of doors to exit stair shafts,
 - b) be not less than 60 mm high, raised approximately 0.7 mm above the surface,
 - c) be located 1 350 mm from the finished floor and beginning not more than 150 mm from the door, and
 - d) be contrasting in colour with the surface on which they are applied. (See Appendix A.)

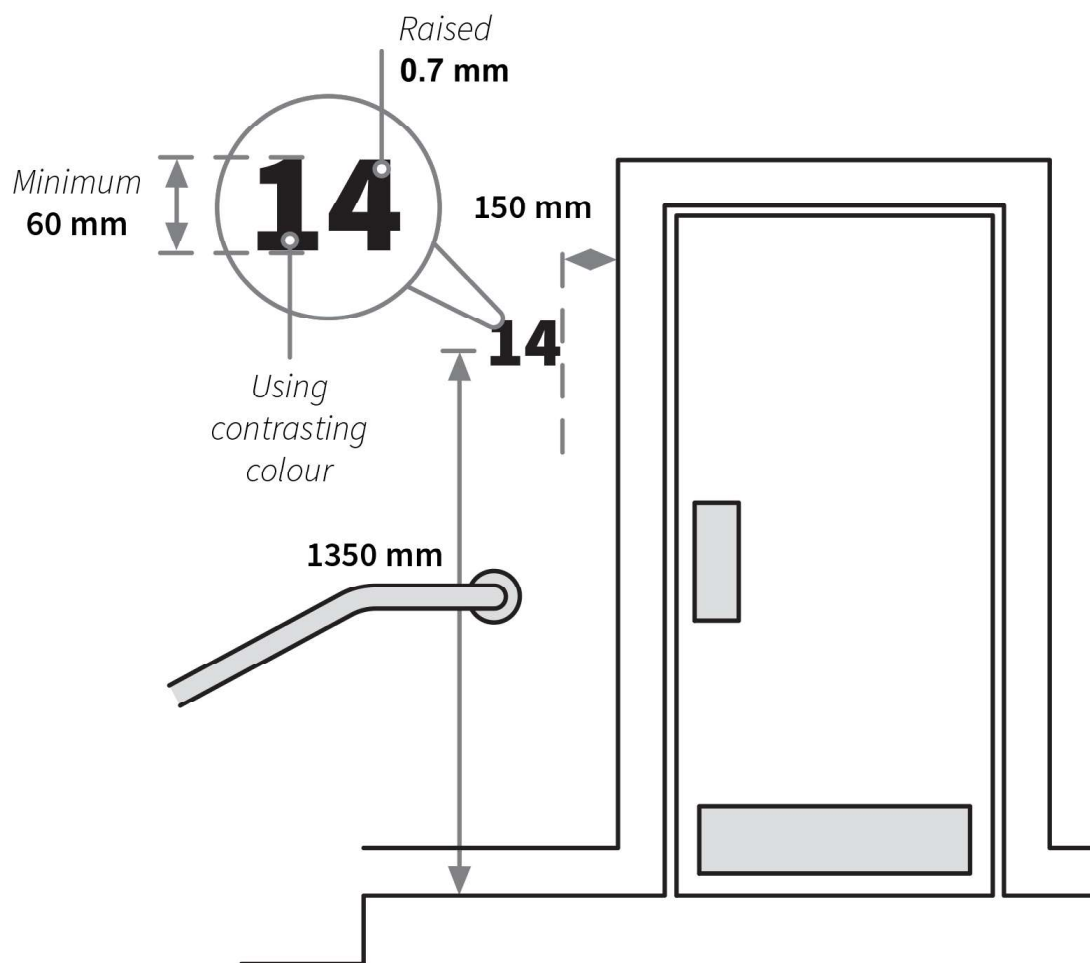

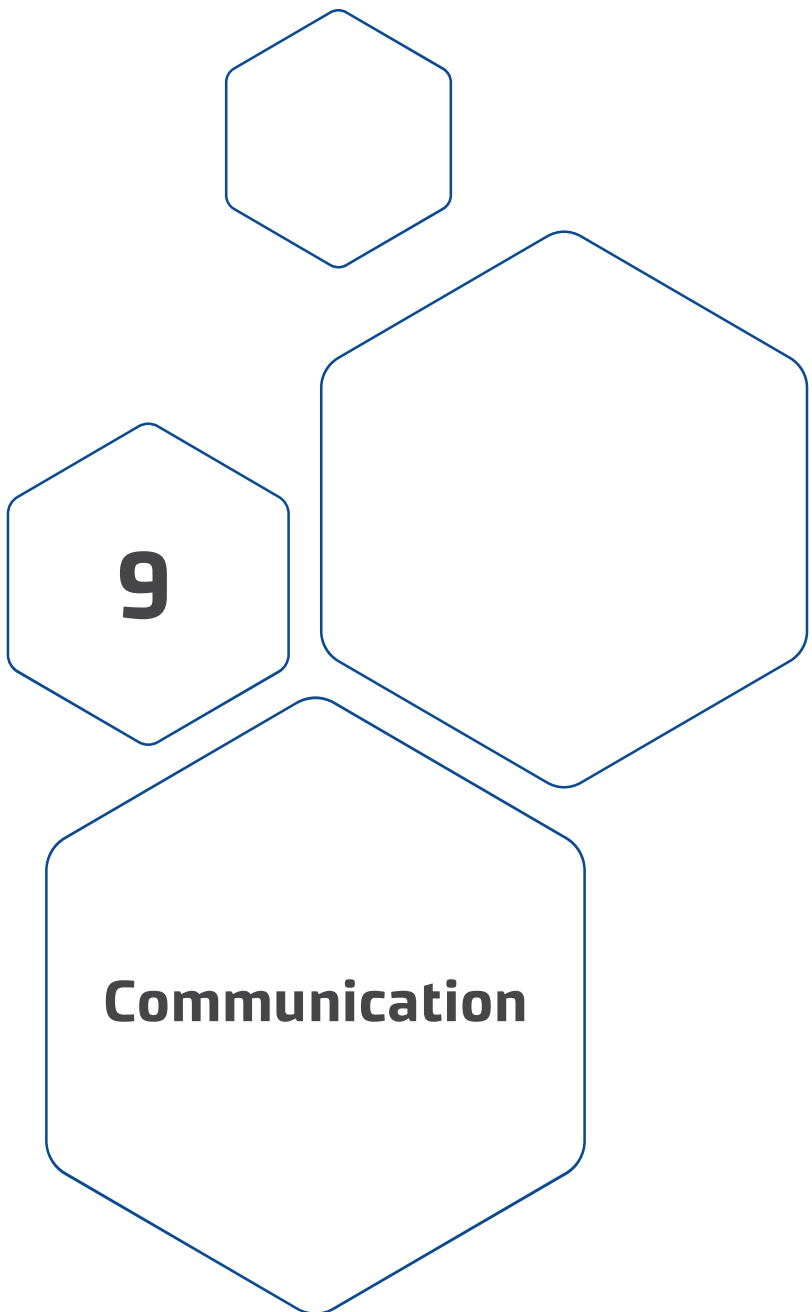



Communication

Entrance Security System

Entrances equipped with electromagnetic locks as part of a security system can create difficulties for people with hearing loss. Some entrances in walk-up apartments, for example, have security locks that are released from a remote location, such as a tenant's suite. Barrier-free design requires that both an audible and visual signal be provided to alert visitors that the locking mechanism is deactivated.

3.8.1.2. Entrances

- 1) If an entrance is equipped with a security system, both visual and audible signals shall be used to indicate when the door lock is released.

The installation of a telephone keypad configuration (like the recent CSA-approved design of the telephone keypad configuration for use in elevators) would be beneficial for all visitors for calling tenants from security entrances. Searching columns of buttons and corresponding long lists of names is time-consuming and often impractical, if not impossible, for visitors with visual disabilities.

Public Telephones

3.8.3.15. Shelves or Counters for Telephones

(See Appendix A.)

- 1) If built-in shelves or counters are provided for public telephones, they shall be level and shall
 - a) not be less than 265 mm deep,
 - b) have, for each telephone provided, a clear space adjacent to the phone, not less than 265 mm wide, having no obstruction within 265 mm above the surface.
- 2) The top surface of a section of the shelf or counter described in Sentence (1) serving at least one telephone shall be not more than 865 mm above the floor.
- 3) If a wall-hung telephone is provided above a shelf or counter section as described in Sentence (2), it shall be located so that the receiver and coin slot are not more than 1 370 mm above the floor.
- 4) At least one telephone with a built-in telecommunication device for the deaf (TTY/TDD) shall be provided if public telephones are installed.

Telephone Service

To make it accessible, an area of 1 500 mm × 1 500 mm is required to provide space to manoeuvre a wheelchair in front of a public telephone. Coin slots and other features shall be within reach of a person sitting in a wheelchair. These should not be higher than 1 370 mm above the floor. A fold-down seat should be provided in order to make it easier to read an LCD screen or type messages on the keyboard. To add flexibility, a shelf or counter should be provided for setting down a portable teletypewriter (TTY) or a computer.

This space shall be 265 mm deep and 265 mm wide, shall have a 265 mm clearance above it, and shall be located no more than 865 mm above the floor.

Along with the foregoing measurements, any public telephone or bank of telephones should retain a cane-detectable partition in order for a person with visual disabilities to detect that s/he is approaching an area with projecting shelves and telephones.

A TTY provides a screen and keyboard for transmitting visual messages. There are two types of devices: portable devices that can be used with any telephone, and devices that are built into the bases of public telephones. The latter are expensive and should be placed in areas that are supervised, in order to prevent vandalism. In large complexes, such as shopping malls, where more than one bank of pay telephones is provided, signs should indicate the location of the TTY.

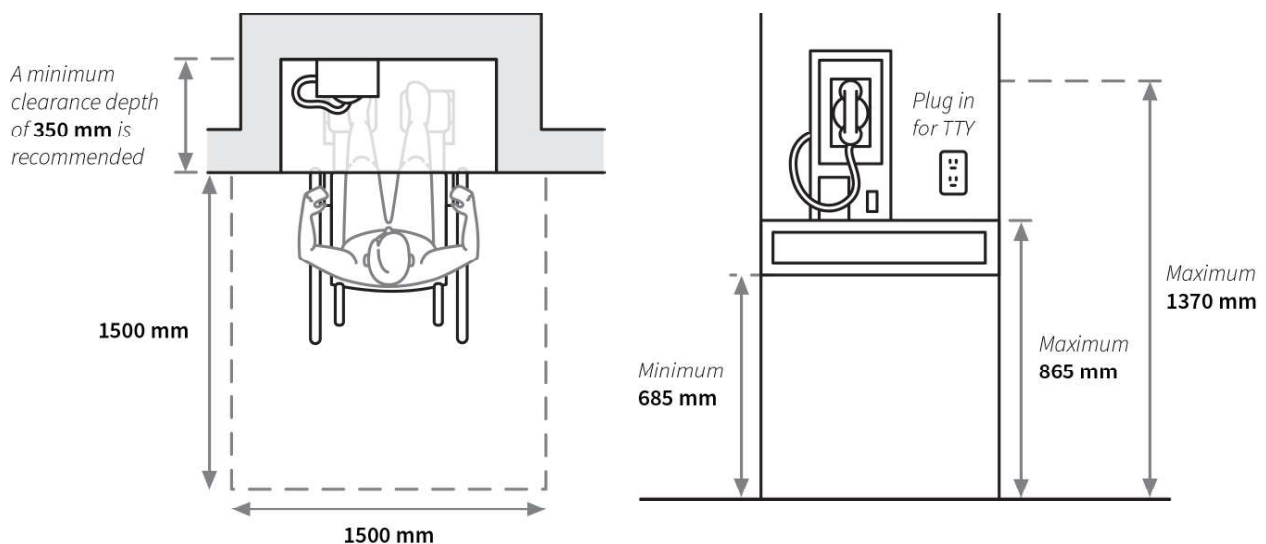

Assistive Listening Devices

3.8.3.7. Assistive Listening Devices

(See Appendix A.)

- 4) Except as permitted by Sentence (2), in a building of assembly occupancy, all assembly areas with an area of more than 100 m² shall be equipped with an assistive listening system encompassing the entire seating area.
- 5) If the assistive listening system required by Sentence (1) is an induction loop system, only half the seating area in the room need be encompassed.

FM or infrared systems can be designed to broadcast signals that cover the entire room, and thus do not restrict seating to any one area. The diagram shows the general configuration of FM and infrared systems. The transmitter for these wireless systems can be connected to the existing sound system amplifier, or be used independently with separate microphones.

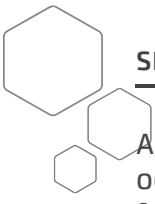

SECTION 9

Assistive Listening Devices (ALD) should be installed in all areas of any building where occupancy might be 50 persons and more. The appropriate number of ALDs required for each area can be determined with the assistance of the Canadian Hard of Hearing Association.

These same organizations can assist in choosing the most appropriate system (including information on cost, installation, and maintenance; suitability to the audience; ease of operation; and attention to the need for privacy) and report on designers and suppliers.

FM or IR Systems can be installed when the background EMI is greater than -32 DBs (-20 DB's, for example).

Where secure transmission of Audio is a requirement then an IR System should be installed.

All Assisted Listening Systems should be checked once per year to ensure proper operation.



Best Practice

Health Care locations manned by staff should be equipped with a magnetic counter loop system and the “t coil” symbol should be displayed. Examples of locations include pharmacies, reception areas and admitting stations in hospitals, assisted living, and extended-care reception areas.

Public areas that require PA systems for reasons of safety should be equipped with a magnetic induction loop systems.

- Airports
- Train platforms
- Public transportation vehicles (buses, LRT cars, taxi cabs)

Where an induction loop system is deployed, the building should have 1 loop receiver for every 50 occupants so that people without hearing aids or with hearing aids that do not have a “t coil” will be able to receive the audio using the loop receiver and a hearing appliance.

In areas where there is seating, only half of the seating area in a room needs to be encompassed.

Installation of induction loop shall comply with the IEC60118-4 2014 standard, and a Certificate of Conformity should be issued to insure proper operation; the installer should supply a Certificate of Conformity.

Once per year, each loop installation should be checked and a Certificate of Conformity shall be issued.

The Canadian Hard of Hearing, Edmonton Branch can be consulted for more information, as well as installers and suppliers of designs and systems.

Assistive Listening Device Systems

Wireless sound transmission systems, such as FM, infrared, or an induction loop, improve sound reception for those who are hard of hearing by providing amplification that can be adjusted by the user. In many cases the only way to increase speech intelligibility is to cut the distance between the sound source and the listener and at the same time reduce the present noise. This can basically be achieved with the use of three different techniques: induction loop, radio (FM), or infrared (IR) systems. These systems block out unwanted background noise. They transmit signals that are picked up by special receivers worn by the person who has a hearing impairment. This person does not necessarily have to use a hearing aid. These systems do not interfere with the listening enjoyment of others.

Audio-frequency induction-loop systems are widely used to provide a means for hearing aid users, whose hearing aids are fitted with induction pick-up coils, generally known as “telecoils.”

In normal use, hearing aids are equipped with a highly sensitive microphone for amplifying near-field speech. While this is effective for local conversations/quiet environments, it is less effective for listening to speech or music at a distance or in front of a security screen at a ticket counter. This is because the hearing aid’s microphone also picks up any background noise in the room and unwanted speech from other conversations. An induction loop system works by moving the required sound closer to the hearing aid via the hearing aid’s telecoil, which is activated by turning it to the “T” or “MT” position.

Hearing aids do not just amplify all frequencies equally; they are tailored to suit the user’s hearing requirements and amplify different bands by different amounts. This gives maximum intelligibility, so the user has the best chance of understanding what is said. The t coil is incorporated so that the audio that is received by the t coil is then amplified in the same way that the microphone is, and thus maximum intelligibility is obtained. Hearing aids with a telecoil can be set to receive only the audio from the t coil and all signals, including background audio, are not picked up, further increasing speech intelligibility. When set to the microphone and t coil setting, there is a mix of the two signals and the intelligibility is somewhat reduced, depending on the ratio of microphone to t coil signal. Individuals requiring hearing assistance can use a loop receiver (loop listener) that amplifies the audio, and the user then uses a headphone or earphone but in the same manner as the IR or FM system.

When the background EMI (Electrical Magnetic Interference) is less than -32DBs, transmission of an audio-frequency signal via an induction-loop system establishes an acceptable signal-to-noise ratio in conditions where a purely acoustical transmission would be significantly degraded by reverberation and background noise.

Induction-loop systems are installed in churches, theatres, cinemas, music halls, airports, arenas, ferries, trains, etc., for the safety and richer listening experience of hearing-impaired people. The use of induction-loop systems has been extended to many transient communication situations such as ticket offices, bank counters, drive-in/drive-through service locations, lifts/elevators, etc.

There are three types of loop configuration: counter loops used for transient communication systems (background EMI should be -22 DBs or less); perimeter loops where magnetic spillage or significant metal in the structure is not an issue; and a phased array system that keeps the magnetic field contained in a room (allowing adjacent rooms to have a looped system and have each system isolated from the other) and overcomes absorption, which may not be possible with a perimeter design.

The induction loop system requires users to sit in the area circumscribed by the loop. Though installation of the loop is relatively simple, the installer should be knowledgeable about these systems to ensure proper functioning.

FM or infrared systems can be designed to broadcast signals that cover the entire room, and thus do not restrict seating to any one area. The diagram shows the general configuration of FM and infrared systems. The transmitter for these wireless systems can be connected to the existing sound system amplifier, or be used independently with separate microphones.

Generally, the systems installed in church halls, auditoria, theatres, and similar places of assembly are not portable; they are installed as part of the fixed-sound system for the facility.

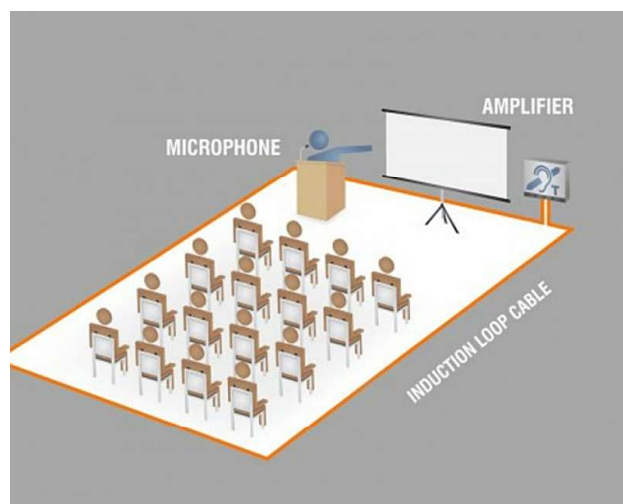

Hard-wired systems (where a jack is provided at a particular seat) require special individual volume control provisions to accommodate people with varying degrees of hearing impairment.

Signage

3.8.3. Design Standards

3.8.3.1. Accessibility Signs

- 1) Signs incorporating the international symbol of accessibility for persons with physical disabilities shall be installed to indicate the location of a barrier-free entrance. (See Appendix A.)
- 2) A washroom, shower, elevator or parking space designed to be barrier-free shall be identified by a sign consisting of the international symbol of accessibility for persons with physical disabilities and by appropriate graphic or written directions to indicate clearly the type of facility available. (See Appendix A.)

- 3) Facilities and services for persons with a specific disability shall be identified using nationally recognized symbols.
(See Appendix A.)
- 4) Accessibility signs for universal toilet rooms shall be installed in accordance with Clause (5)(b).
- 5) Where tactile signage is installed, it shall
 - a) be not less than 60 mm high, raised approximately 0.7 mm above the surface,
 - b) be located not more than 1 200 mm above the finished floor,
 - c) begin not more than 150 mm from the door or entrance,
 - d) be contrasting in colour with the surface on which it is applied, and
 - e) include Braille identification by use of Braille dots not less than 1 mm in relief, located directly below the tactile signage.

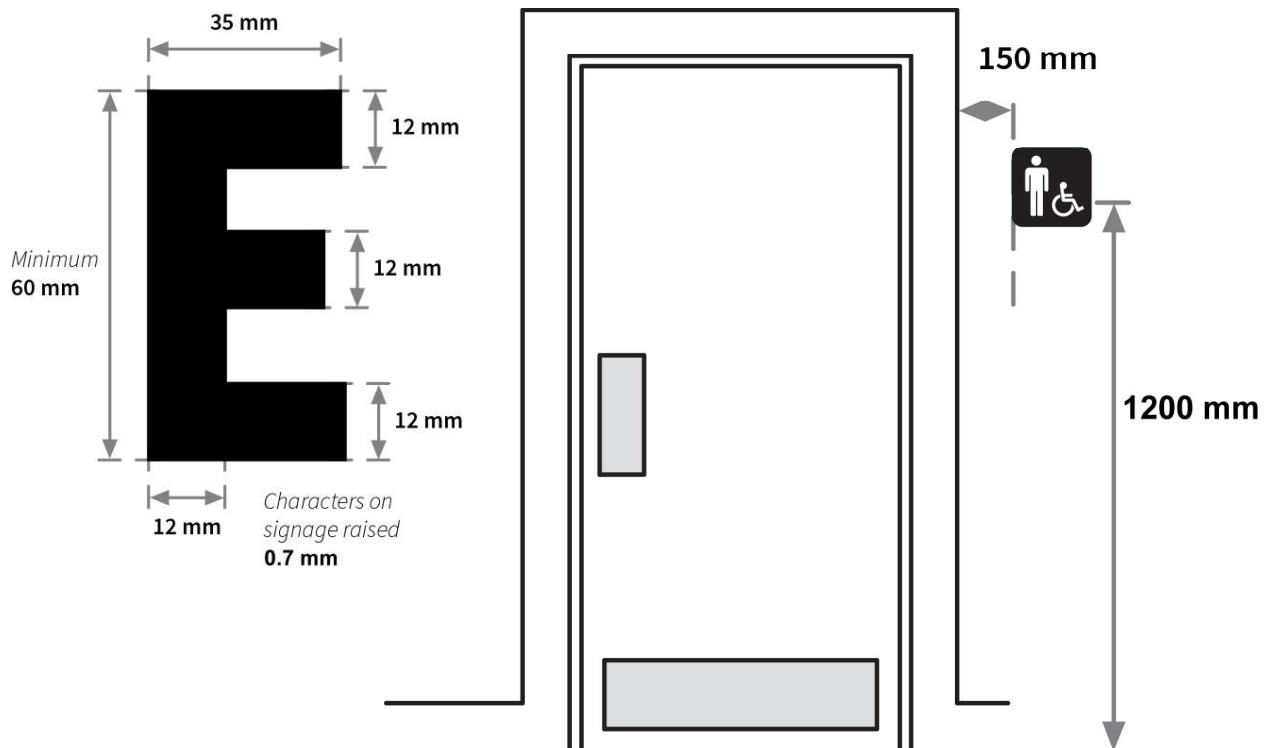

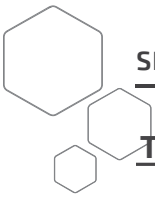

The International Symbol

The international symbol indicates that persons with disabilities will have reasonable freedom of movement within a building so signed. The symbol is usually white on a blue background. Where the colours do not stand out, the symbol can be in blue on a white background. Though other contrasting colours may be used, these should be avoided if possible. An arrow can be added to indicate direction or the location of an accessible space or facility.

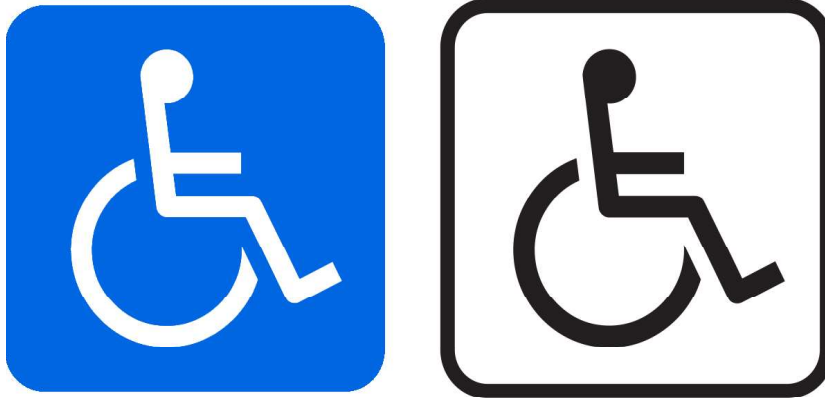

Additional Symbols

Facilities provided for people with hearing impairments shall be indicated with a symbolic ear with the beginnings of a line through it.

Facilities provided for those with visual impairments shall be indicated with a figure using a white cane.



Alternate Forms of Communication for People with Visual Disabilities

Recent technology (such as a product known as Talking Signs) offers infrared wireless communication systems, where pedestrians who are visually impaired may use a receiver to pick up remote directional voice messages. Destination points in a structure can be equipped with infrared equipment that provides beams of invisible light to receivers that pedestrians would use. Verbal messages can then be provided through the receiver directly or through a headset. Such technology may be used in both internal and external environments. This would, for people who have visual impairments, either augment or replace the need for sighted guides or tactile/high-contrast directories.

Signage

People with visual disabilities rely on cues to find their way. Doors and openings that lead from public places and through which the public is permitted to enter should be identified by specific tactile signs with letters not less than 60 mm high, raised 0.7 mm above the surface,

located 1 200 mm above the floor surface, and beginning not more than 150 mm from the door openings.

Accessibility for Persons with Visual Disabilities

Persons with visual disabilities rely on

- lighting cues, i.e., the intensity and distribution of lights used to accent areas and passageways,
- audible cues, i.e., subtle sounds, such as a fountain, clock, music, machine, or verbal announcement, to help with orientation,
- tactile cues, i.e., different types of flooring that mark a pathway, or change from one area to another, thus serving as a warning that a change in direction is to take place,
- colour/contrast cues, i.e., used to define the location of doorways, building controls (such as light switches and thermostats) and protruding elements, such as handrails and fire extinguishers, and
- ergonomic cues, i.e., the design of rooms and the arrangement of furnishings that allow people to move efficiently and safely along pathways within rooms and from room to room.

Accessibility for Persons with Language Difficulties

The use of graphics or internationally recognized symbols to indicate direction or identify facilities and services will be beneficial to persons with

- developmental disabilities,
- learning disabilities,
- brain injuries,
- mental illnesses causing disorientation or confusion, and
- little or no knowledge of the local written language.

However, if wording is to be used on signs, the language on them should be simple and concise to be accessible for most building users.

Directories

Building directories should be conveniently located, tactile in nature, and located on a sloping plane 760 mm to 900 mm above the floor. Characters that are raised at least 0.7 mm are needed.

Persons who are blind can be given directions by the use of pre-recorded messages or the use of tactile maps and signs. Guide dogs and canes are also used to aid the blind. Those with visual disabilities or who are deaf-blind rely on the following cues for orientation:

- colour contrast/brightness
- changes in illumination
- sounds



SECTION 9

- textures (different flooring materials to indicate change in direction or use)
- standard architectural features
- patterns
- placement of elements

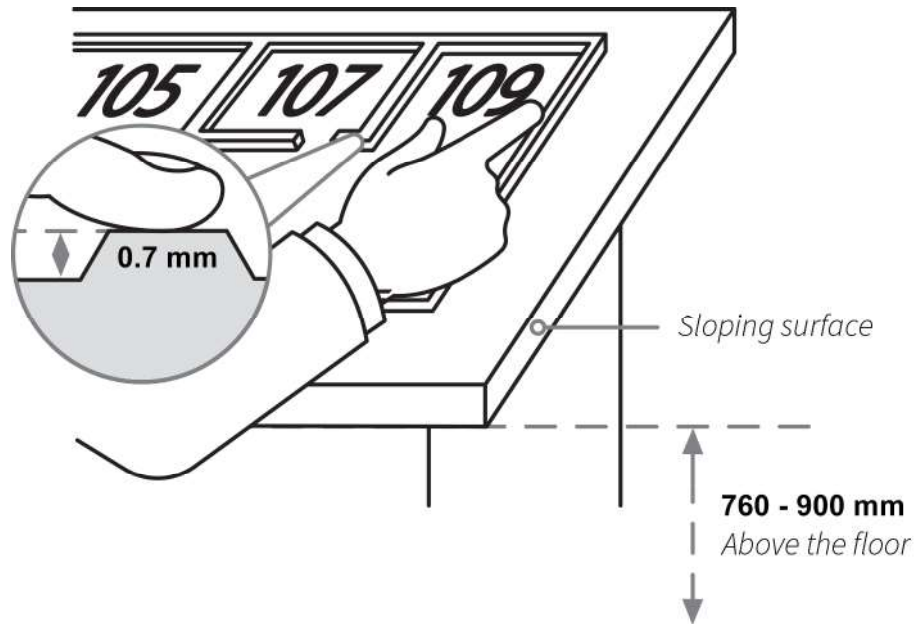

Colour Contrast

The identification of floors and other signs intended to help orient people who are visually disabled should offer maximum colour contrast to be effective. For this reason, it is recommended that white on black or black on white is used, as this combination produces the best legibility.

It is also recommended that sign surfaces be processed to prevent glare. Assigned floor numbers should have a glare-free surface and be mounted on a background in a contrasting colour.



10

**Accessibility
in Vicinity of
Construction
Sites**



Accessibility in Vicinity of Construction Sites

Application of this Code

- 6) This Code applies to any one or more of the following:
 - i) the correction of an unsafe condition in or about any building or property,
- 1) safety during construction of a project, including protection of the public and neighbouring properties.

Consistent application of Alberta Building Code (ABC) to public protection provisions around construction sites will lead to safer design and maintenance of temporary public ways which, though usually under the control of a municipal agency such as a transportation, public works or police department, fall under the purview of the building code and fire code.

Existing ABC provisions are often overlooked due to the temporary nature of a construction environment. Whether at one location alone or in closely spaced projects, sidewalk and crossing disruption can be challenging for anyone. These same conditions can present insurmountable obstacles for persons with disabilities moving to and from work, home, errands, or for pleasure. Consideration for the public passing by or through a demolition or construction site is an obligation of ABC.

8.1.2.2. Protection from Risk

- 1) Precautions shall be taken to ensure that no person is exposed to undue risk.

Regulatory requirements for construction areas should be consistently applied in order to address safety objectives and meet user expectations, and avoid unsafe conditions by establishing temporary pedestrian routes in thoughtful balance with site access and emergency response realities.

8.2.3.1. Safe Passage Past Site

- 1) Except as provided in Article 8.2.3.2., provisions shall be made at all times for the safe passage of pedestrian and vehicular traffic past the site.

All pedestrians shall be provided with safe passage through or around any construction or demolition site that requires ABC Part 8-mandated temporary closure or adjustment of the public way, building access, or egress routes. The aim is to remove as many barriers as practical for persons with disabilities of all sorts, as well as for those without.

8.2.1.1. Covered Way Exceptions

- 1) Where the construction may constitute a hazard to the public, work shall not commence on the construction, alteration or repair of a building until a covered way has been provided as described in Article 8.2.1.2. to protect the public, except where
 - a) the work is done within a solid enclosure,
 - b) the building is at a distance of 2 m or more from a public way used by pedestrians, or
 - c) site conditions warrant a distance greater than provided in Clause (b).

8.2.1.2. Covered Way Construction

- 1) A covered way shall
 - a) have a clear height of not less than 2.5 m,
 - b) have a clear width of not less than 1.5 m or the width of the public way, whichever is the lesser,
 - c) be designed and constructed to support safely all loads that may be reasonably expected to be applied to it, but in no case less than 2.4 kPa on the roof,
 - d) have a weathertight roof sloped towards the site or, if flat, be equipped with a splash board not less than 300 mm high on the street side,
 - e) be totally enclosed on the site side with a structure having a reasonably smooth surface facing the public way,
 - f) have a railing 1 070 mm high on the street side where the covered way is supported by posts on the street side,
 - g) be adequately lighted when the public way is lighted, and
 - h) have, at each opening for pedestrian access, a gate not less than 1 200 mm high that can be locked or bolted in a closed position.

A covered way shall be constructed with all users in mind. The minimum clear width of 1.5m generally works adequately for modest use level. On major streets, sidewalks that experience crowding at certain times of day should be provided with a wider covered way, typically extending no closer than 30 cm to the street curb, to be comfortable for all. Check early in the process whether the municipality has additional local regulations governing the use of streets and public property so that a viable management plan can be formulated.

8.2.3.1. Safe Passage Past Site

- 3) Except as provided in Sentence (4), where a sidewalk exists adjacent to the site, it shall be kept clear of obstructions at all times.

Materials, scrap, and equipment cannot be placed on the walking surface as this poses a hazard for all users. Care is called for in erecting fences and covered ways so that no objects protrude beyond the cane-detectable zone.

8.2.3.1. Safe Passage Past Site

- 4) Where construction operations necessitate the obstruction of a sidewalk, a temporary sidewalk shall be provided and it shall be kept clear of obstruction at all times.

Where an existing sidewalk adjacent to a site is closed, a common solution is to arrange a temporary walking surface that replicates to the greatest extent practical the positive characteristics of the existing walk being closed. Handrails and clearly demarcated temporary ramps with detectable warnings may be needed. Grates and rough surfaces on a roadway placed in temporary service as a walkway may need mitigation. Ensure that temporary walking surfaces such as plywood are selected for slip-resistance even when wet. Mud, snow, and ice accumulations require timely attention.

SECTION 10

Intelligible signage provides the public sufficient and meaningful notice of closure, detour, or delay and alternatives. Use symbols, arrows, and large-sized print text in contrasting colours identified with safety and danger (for example, ISO7010:2011 Graphical symbols—safety colours and safety signs used in workplaces and public areas). Advance notice—time and positional—results in more-informed decisions by all users before arriving at a point where walking in the road or near a hazard is considered preferable to backtracking.

Ongoing active management of the area around the site will ensure that the signage, fences and barricades are maintained and adjusted appropriately to changing conditions.

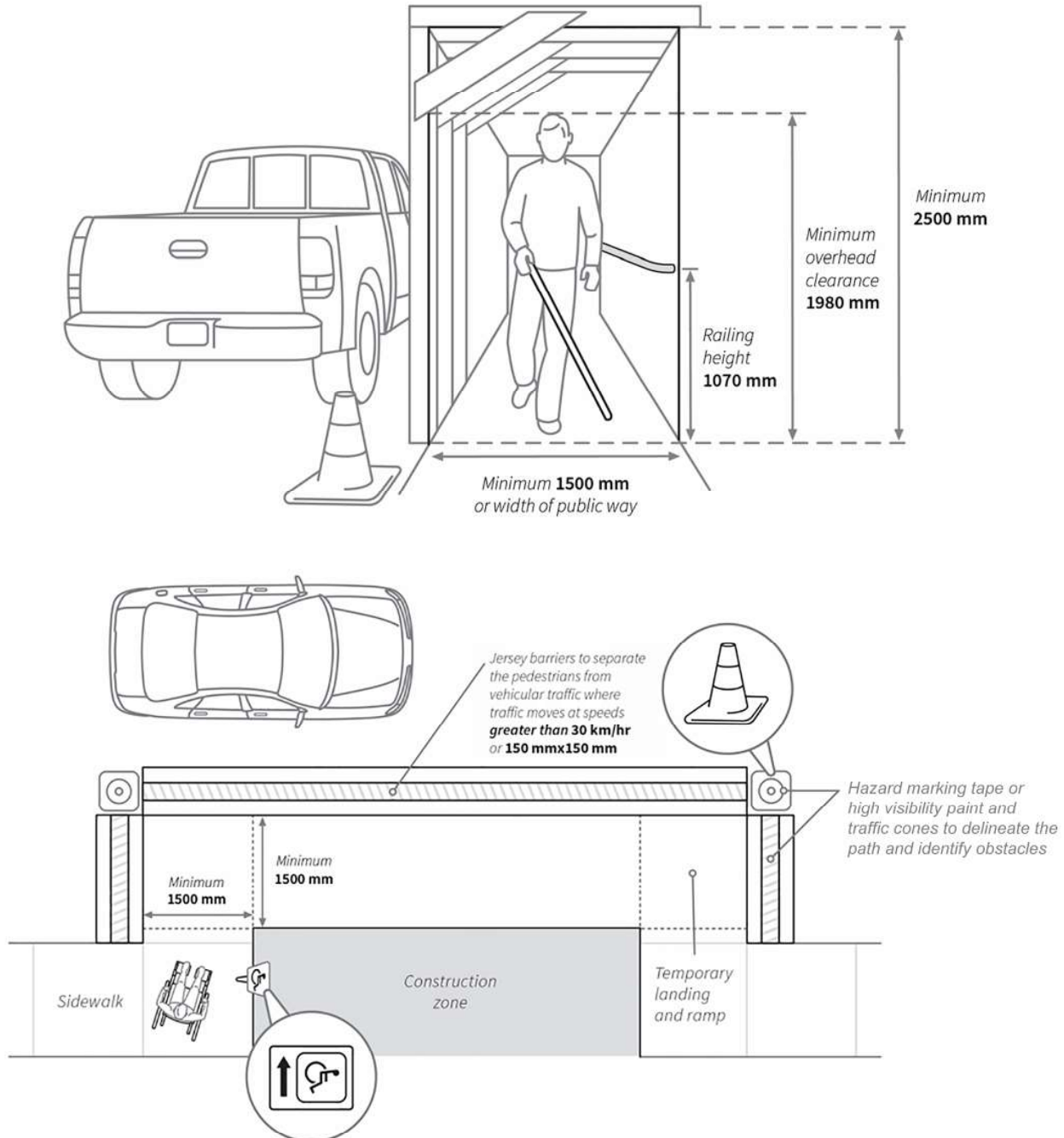

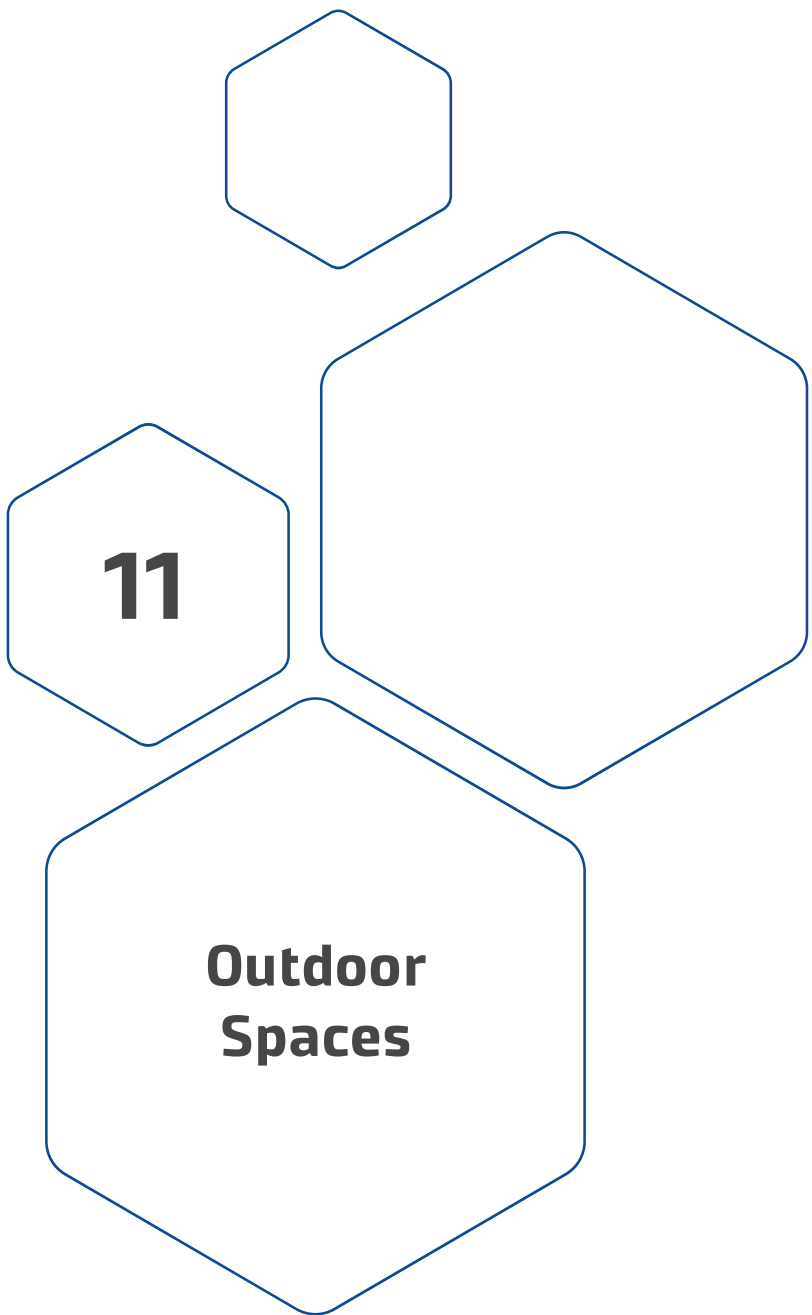

11

**Outdoor
Spaces**

Outdoor Spaces

The following section is reprinted with permission from the City of Markham Accessibility Guidelines (2011) Sections 6.15-6.20 & the City of Ottawa Accessibility Design Standards, 2nd ed. (2015) Sections 6.14-6.19.

Outdoor Public Use Eating Areas



Reference

Sec. 2.6 Rest Area
 Sec. 2.10 Seating, Tables and Work Surfaces
 Sec. 3.3 Exterior Paths of Travel
 Sec. 4.5 Washrooms

Application

This section applies to newly constructed and redeveloped outdoor public use eating areas at public facilities, which typically provide tables (e.g., picnic tables) intended for public use as a place to consume food.



Best Practice

Disperse the locations of accessible tables in outdoor public use eating areas to provide a choice for users with disabilities.

Consider fixing accessible tables and seating so that they cannot be moved to an inaccessible location.

Design and Layout

- a) ensure a minimum of twenty percent (20%) of tables and no fewer than one (1) in outdoor public use eating area are accessible;
- b) ensure accessible tables provide suitable knee and toe clearances (Figure 105b);
- c) provide a clear space of 2000 mm (minimum) on all sides of the table (Figure 105a);
- d) locate on an accessible path of travel or trail;
- e) ensure ground surface leading to and under tables is firm, stable, and no steeper than 1:50 (2%);
- f) provide directional signage at strategic locations to identify the location(s) of accessible tables and or public use eating areas;
- g) where barbecues are provided in outdoor public-use eating areas, ensure that they are placed away from the accessible path of travel and on a surface with high tonal and textural contrast with the adjacent surfaces; and
- h) where washrooms are provided, ensure accessible features (e.g., at least one universal toilet room per cluster of regular washrooms).

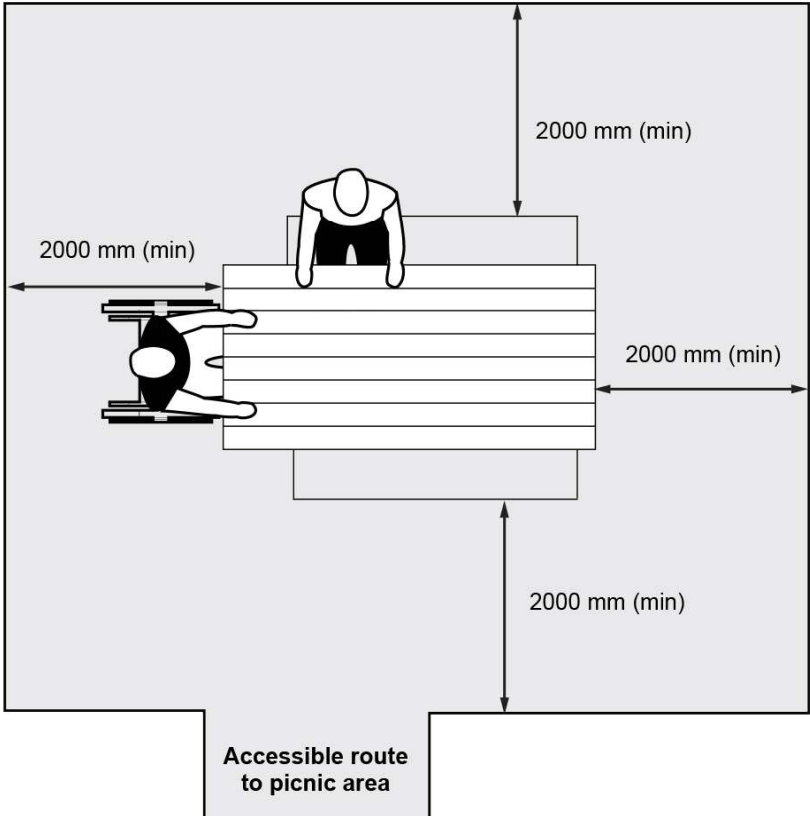

Figure 105a: Picnic Table Design and Features-Plan View

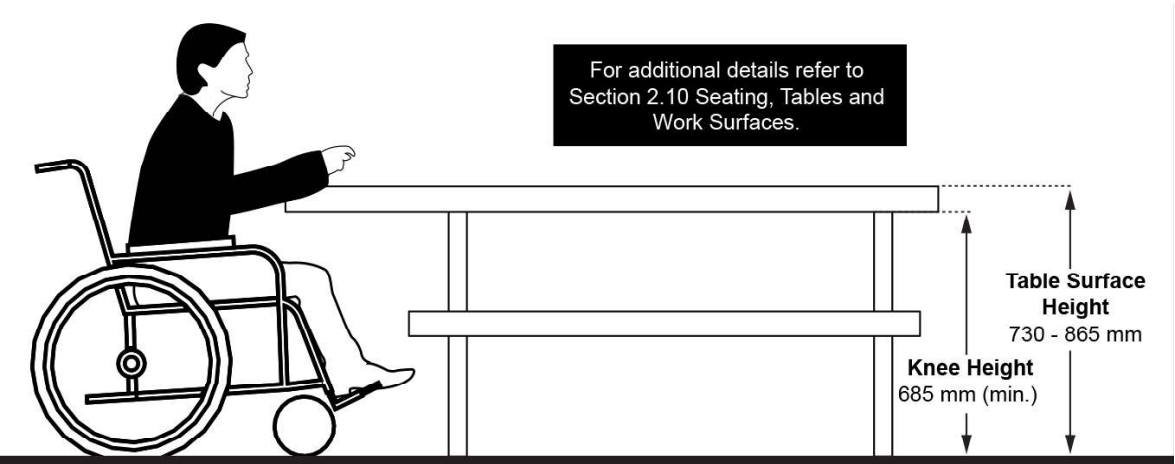

Figure 105b: Picnic Table Design and Features-Elevation View

Recreational Trails, Beach Access Routes, and Boardwalks



Reference

Sec. 2.1 Ground and Floor Surfaces
 Sec. 2.2 Ramps
 Sec. 2.4 Guards and Handrails
 Sec. 2.5 Overhanging and Protruding Objects
 Sec. 2.6 Rest Areas
 Sec. 2.10 Seating, Tables and Work Surfaces
 Sec. 3.3 Exterior Paths of Travel
 Sec. 5.8 Signage and Wayfinding
 Sec. 6.14 Outdoor Public Use Eating Areas

Application

This section applies to:

- newly constructed and redeveloped recreational trails that the City intends to maintain; however, it does not apply to trails solely intended for cross-country skiing, mountain biking, or the use of motorized snow vehicles or off-road vehicles, wilderness trails, backcountry trails, and portage routes;
- newly constructed and redeveloped beach access routes that the City intends to maintain, including permanent and temporary routes that are established through the use of manufactured goods, which can be removed for the winter months; and
- boardwalks that are part of newly constructed or redeveloped recreational trails and beach access routes that the City intends to maintain.

Recreational Trails

Consultation Requirements

Before constructing new or redeveloping existing recreational trails, the City will consult with the Accessibility Advisory Committee, the public, and persons with disabilities on:

- a) the slope of the trail;
- b) the need for, and location of, ramps on the trail; and
- c) the need for, location and design of,
 - i. rest areas;
 - ii. passing areas;
 - iii. viewing areas;
 - iv. amenities on the trail; and
 - v. any other pertinent feature.



Note

Trails are not considered the same as exterior routes, paths, and walkways. Trails do not include pathways such as public sidewalks or pathways between buildings.



Best Practice

Trails with options for entry and exit at multiple trailheads typically can enhance accessibility when requirements of this section are integrated.

Designated Trailheads

- a) ensure that designated trailheads with information signage are integrated as part of the trail design at key entrance and exit points along the trail, intermediate areas on lengthy trails, or decision points (e.g., changes in elevation or where there is option to go in multiple directions) where required. Typically, a case-by-case review and analysis is required, based on trail type, location, and other conditions (Figure 106).



Figure 106: Example of Trail with Multiple Trailhead Options



Note

A trailhead is a designated point of access that may contain a parking area, information kiosks, information signage, rest areas, washrooms, water fountains, or other user amenities, which are typically reached by vehicular or pedestrian access.

Trail Entrance/Exit Points

- a) provide 850 mm to 1000 mm clear opening whether entrance includes a gate, bollard, or other entrance design; and
- b) ensure that entrances are maintained and clear of obstructions that can reduce the clear width of the entrance.

Trail Clear Width

- a) provide clear width of 1000 mm (minimum) to 1800 mm (preferred);
- b) where the clear width is less than 1800 mm, provide a passing space of 1800 mm wide by 1800 mm (minimum) long, at intervals no more than 30 m (Figure 107);
- c) ensure headroom clearance is 2100 mm (minimum) above the trail; and
- d) ensure that there are no obstructions or projections along trail.

Note

Where trail width is minimal, ensure that this occurs for the shortest distance possible.

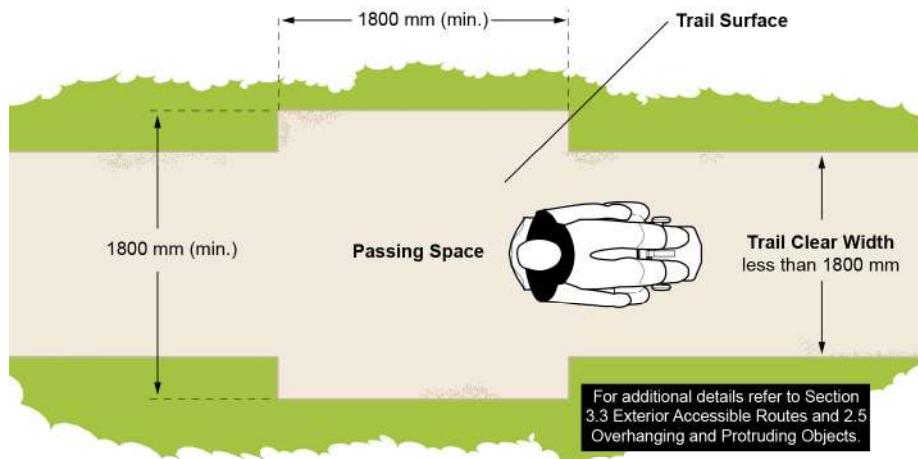

Figure 107: Trail Clear Width

Trail Surfaces

- ensure that surface is firm and stable;
- ensure that openings must not allow passage of an object that has a diameter of more than 20 mm (13 mm diameter preferred), and that any elongated openings are oriented approximately perpendicular to the direction of travel;
- ensure that surface is resistant to damage by normal weather conditions, with ability to sustain typical wear and tear between planned maintenance cycles; and
- ensure that type of surface used and expected conditions that may change over time are identified in information signage provided at trailhead.

Best Practice

Where running or cross slopes exceed 1:20 (5%), provide level rest areas, 1800 mm by 1800 mm (minimum), every 30 m.

Note

For detailed guidance on trail surface design and slope requirements for unique conditions, refer to the “Ontario’s Best Trails Guidelines and Best Practices for the Design Construction and Maintenance of Sustainable Trails for All Ontarians” resource document.

Trail Running and Cross Slopes

- provide a running slope that is as gentle as possible, as permitted by the terrain, to minimize amount of strength and stamina required to use the trail; and
- ensure that cross slopes are as gentle as possible, as permitted by the terrain, to provide an even surface for diverse users, including people using mobility aids or have difficulty with balance.

Ramps

Where ramps are provided on trails:

- provide a running slope no greater than 1:10 (10%); and
- with the exception of the running slope, ensure compliance with ramp requirements from Section 2.2 and elsewhere in this document.



Note

Colour, texture, and tonal contrast can be integrated to assist users with identification of edge protection.

Edge Protection

Where recreational trails are constructed adjacent to water or a drop-off, provide edge protection with the following requirements:

- constitute of an elevated barrier that runs along the edge the recreational trail to prevent users from slipping over the edge;
- have the top of the edge protection at 50 mm (minimum) high above the trail surface; and
- be designed so as not to impede the drainage of the trail surface.



Example of protective barrier where there is a large elevation change, or trail is adjacent to water feature.



Exception

Where there is a protective barrier that runs along the edge of a recreational trail that is adjacent to water or a drop-off, edge protection does not have to be provided.



Best Practice

Existing trails for which information has not been developed should be marked (e.g., temporary site signage) to indicate that the information is not yet available and the expected date it will be available.

Use multiple communication strategies to provide trail information, including on site (e.g., maps, trailhead kiosk or vertical signage), in alternate formats at key City locations, and online (e.g., City website or trail related websites, such as “Trail Explorer”, www.trailexplorer.org).

Trailhead Signage

- a) For each trailhead along recreational trails, provide signage with the following information (Figure 108):
 - i. the length of the trail;
 - ii. the type of surface of which the trail is constructed;
 - iii. average and minimum trail width;
 - iv. average and maximum running and cross-slopes;
 - v. the location of features and amenities, where provided;
 - vi. extreme or unique conditions (e.g., steep slopes, obstacles, or narrow widths); and
- b) ensure that signage text has high tonal contrast with its background in order to assist with visual recognition, with text that includes characters that use a sans serif font.

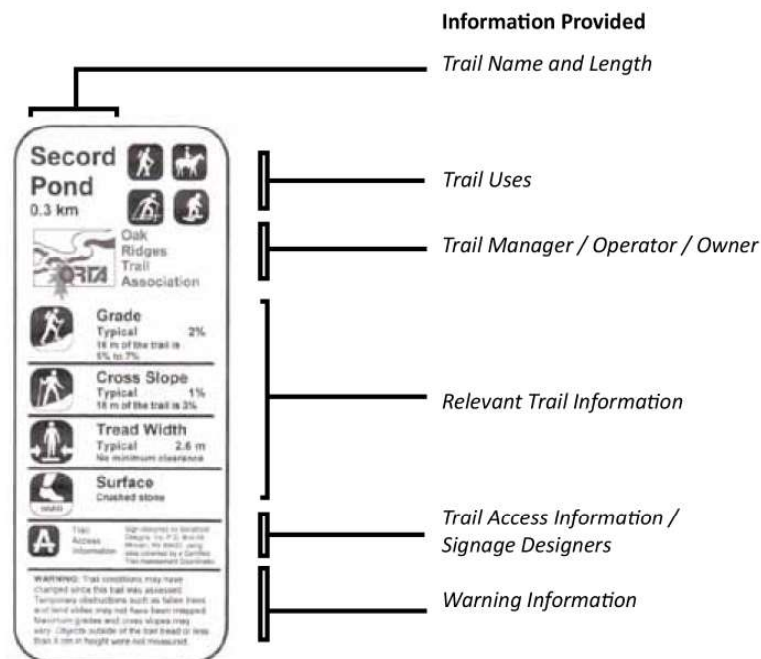

Figure 108: Example of Typical Universal Trail Assessment Process (UTAP) Signage



Best Practice

Provide contact information at trailheads where the public can report any damages, safety hazards, or vandalism on the trail.



Note

The information provided must be objective to allow users with or without disabilities to make an informed decision before using a trail. This recognizes varied conditions in trail environments but also encourages the maximum use of trails.

Other Media

- a) where other media such as park websites or brochures are used to provide information about the recreational trail, beyond advertising, notice, or promotion, provide the same information identified on the trailhead signage.

Understanding the Universal Trail Assessment Process (UTAP)

The UTAP was developed by Beneficial Designs Inc. and is considered an objective method of documenting trail conditions and evaluating trails accessibility levels.

The UTAP method relies on systematically evaluating trail measurements and data collected by auditors. Auditors begin at a station point (e.g., trailhead) and mark subsequent station points along the trail, which define trail segments. Typically, station points occur where there is a change in the trail characteristics, such as at the beginning/end of a slope, at an intersection, or at a major feature. For each trail segment, key measurements (e.g., running slope, cross slope, surface, width and length of trail) are gathered using the “Segment Data Collection Sheet.”

After collection, the data is entered into the “Trailware” software, which formally evaluates the data based on the UTAP methodology and generates a Trail Access Information (TAI) report. This report can then be used to provide trail accessibility information to all users.



Best Practice

Trail accessibility features should be assessed using the Universal Trail Assessment Process (UTAP).

Additional Resources

Ontario’s Best Trails: www.ontariotrails.on.ca

Trail Explorer: www.trailexplorer.org

Universal Trail Assessment Process (UTAP): <http://www.beneficialdesigns.com/services/trails-shared-use-path-assessments/the-universal-trail-assessment-process-utap>

Beach Access Routes

Entrances

- a) provide 1000 mm clear opening whether entrance includes a gate, bollard, or other entrance design.

Clear Width

- a) provide clear width of 1000 mm (minimum); and
- b) provide headroom clearance of 2100 mm (minimum) above beach access route.

Surfaces

- a) ensure surface is firm and stable;
- b) ensure that openings must not allow passage of an object that has a diameter greater than 13 mm and that any elongated openings are oriented approximately perpendicular to the direction of travel; and



- c) where the surface of the route is constructed (e.g., not natural):
 - i. ensure surface has 1:2 bevel at changes in level between 6 mm and 13 mm;
 - ii. provide a maximum running slope of 1:10 (10%) at changes in level between 14 mm and 200 mm; and
 - iii. provide a ramp where changes in level are greater than 200 mm.

Running and Cross Slopes

- a) ensure the running slope is 1:10 (10%) (maximum);
- b) ensure the cross slope is 1:50 (2%) (maximum), where the surface area of the beach access route is constructed (e.g., not natural); and
- c) where surface area is not constructed, ensure the maximum cross slope is the minimum slope required for drainage.

Ramps

Where ramps are provided on beach access routes:

- a) provide a running slope no greater than 1:10 (10%); and
- b) with the exception of the running slope, ensure compliance with ramp requirements from Section 2.2 and elsewhere in this document.

Boardwalks

Where a recreational trail or beach access route is equipped with a boardwalk, apply the following requirements.

Clear Width

- a) provide clear width of 1000 mm (minimum);
- b) where the clear width is less than 1800 mm, provide a passing space of 1800 mm wide by 1800 mm (minimum) long, at intervals no more than 30 m; and
- c) ensure that headroom clearance is 2100 mm (minimum) above the boardwalk.

Surfaces

- a) ensure surface is firm and stable; and
- b) ensure that openings must not allow passage of an object that has a diameter of more than 20 mm (13 mm diameter preferred), in any direction and that any elongated openings are oriented approximately perpendicular to the direction of travel.

Running and Cross Slopes

- a) ensure that the running slope is 1:20 (5%) (maximum);
- b) where the running slope is steeper than 1:20 (5%), it must meet the requirements for ramps identified in this section; and
- c) ensure that the gradient of the cross slope is the minimum required for drainage.

Edge Protection

- a) provide edge protection that is 50 mm (minimum) high; and
- b) ensure that the design allows suitable drainage of boardwalk surface.

Recreational Trail Design Checklist

Application

The information in this Checklist is intended to assist City Staff when reviewing key design options for providing accessible recreational trails for users of all ages and abilities.

A formal accessibility assessment of recreational trails, using the Universal Trail Assessment Process (UTAP), is recommended for existing recreational trails. The UTAP is considered an objective method of documenting trail conditions and evaluating accessibility levels for diverse users, and is recognized as a current best practice.



Best Practice

The most significant barrier to trail accessibility is a lack of information about the recreational trail conditions. Providing such information will encourage participation and increase independence in trail use. Information on conditions affecting accessibility (e.g., grade, surface, and obstacles) will also allow enhanced planning for assistance if required.



Note

Refer to Section 6.15 Recreational Trails, Beach Access Routes and Boardwalks, for detailed information on accessibility criteria for recreational trails and the UTAP.

Recreational Trail Design Checklist

The following checklist is intended for use by City Staff when reviewing key accessibility design options for new trails. Additional considerations are required for reviewing existing trails (e.g., applying the UTAP), recognizing the variety of trail types and environments that are available.

General Information

Reference (I.D # / Park Name): _____

Reviewed By

Name: _____

Title / Position: _____

Department: _____

1. Key Trail Features

1.1 Trailhead

1.1.1	Are there multiple TRAILHEADS to allow accessible entry and exit points along the trail? Identify number and location of trailheads.	<input type="checkbox"/> Y <input type="checkbox"/> N	Comments:
1.1.2(a)	Are EXTERIOR AMENITIES provided at trailheads (e.g., parking, accessible routes, public washrooms, etc.)? If yes, identify provisions and location of amenities.	<input type="checkbox"/> Y <input type="checkbox"/> N	Comments:
1.1.2(b)	If provided, have the City's amenities been reviewed for compliance with relevant sections of the City of Ottawa Accessibility Design Standards?	<input type="checkbox"/> Y <input type="checkbox"/> N <input type="checkbox"/> N/A	Comments:

1.2 Trail Clear Width

1.2.1	Is the CLEAR WIDTH of the trail at least 1000 mm (1800 mm preferred)? Note: Ensure placement of vegetation and permanent design features (e.g., bollards and decorative boulders) does not create obstruction or projection along accessible route.	<input type="checkbox"/> Y <input type="checkbox"/> N	Comments:
1.2.2	Where there are changes in level along the trail, are EDGE PROTECTION at least 50 mm high provided and edges clearly marked (e.g., colour and texture contrast) to assist identification?	<input type="checkbox"/> Y <input type="checkbox"/> N <input type="checkbox"/> N/A	Comments:
1.2.3	Is the HEADROOM CLEARANCE above the trail at least 2100 mm?	<input type="checkbox"/> Y <input type="checkbox"/> N <input type="checkbox"/> N/A	Comments:

1.3 Trail Slopes

1.3.1	Is the RUNNING SLOPE as gentle as possible, as permitted by the terrain?	<input type="checkbox"/> Y <input type="checkbox"/> N	Comments:
1.3.2	Is the CROSS SLOPE as gentle as possible, as permitted by the terrain?	<input type="checkbox"/> Y <input type="checkbox"/> N	Comments:

1.4 Trail Surface

1.4.1	Is the TRAIL SURFACE firm and stable? Identify type of surface and material used to meet accessibility requirements.	<input type="checkbox"/> Y <input type="checkbox"/> N	Comments:
-------	---	---	-----------

2. Signage

2.1(a)	Is there suitable TRAIL NAME / IDENTIFICATION SIGNAGE at trailheads and key access points, with accessibility features (e.g., large print, use of strong tonal contrast and pictograms) identifying amenities that may be available?	<input type="checkbox"/> Y <input type="checkbox"/> N	Comments:
2.1(b)	<p>If yes, does the signage include the following information:</p> <p style="text-align: right;">Trail Name</p> <p style="text-align: right;">Trail Map</p> <p style="text-align: right;">Trail Length</p> <p style="text-align: right;">Trail Surface Type</p> <p style="text-align: right;">Trail Running Slope (Grade)</p> <p style="text-align: right;">Trail Cross Slope</p> <p style="text-align: right;">Trail Manager / Operator</p> <p>Note: Identifying this information in accessible format allows users of all ages and abilities to make an informed decision about using the trail. Refer to Section 6.15 Recreational Trails, Beach Access Routes and Boardwalks for more information on the UTAP.</p>	<input type="checkbox"/> Y <input type="checkbox"/> N <input type="checkbox"/> Y <input type="checkbox"/> N <input type="checkbox"/> Y <input type="checkbox"/> N <input type="checkbox"/> Y <input type="checkbox"/> N <input type="checkbox"/> Y <input type="checkbox"/> N <input type="checkbox"/> Y <input type="checkbox"/> N <input type="checkbox"/> Y <input type="checkbox"/> N	Comments:
2.2	Have any barriers to accessibility (e.g., steep slopes or difficult topography) along the trail been identified on signage at strategic locations? If yes, describe information to provide on signage.	<input type="checkbox"/> Y <input type="checkbox"/> N	Comments:

3. Additional Considerations

3.1	<p>Does the trail reflect the varied needs of users, the varied natural landscape and the shared desire for varied trail experience?</p> <p>Note: Design should incorporate both sustainable and universal design features to ensure the widest range of users can benefit.</p>	<input type="checkbox"/> Y <input type="checkbox"/> N	Comments:
3.2	Does the trail offer areas for rest and options for shorter or longer on-trail adventures so that trail users can choose the experience that most suit them?	<input type="checkbox"/> Y <input type="checkbox"/> N	Comments:
3.3	Is there a policy in place to address maintenance issues for trails designed for year-round use (e.g., removal of debris and obstructions on trail surfaces etc)?	<input type="checkbox"/> Y <input type="checkbox"/> N	Comments:
3.4	If reviewing the design of an existing trail and related environments, has the UTAP been implemented to address the needs of diverse trail users of all ages and abilities?	<input type="checkbox"/> Y <input type="checkbox"/> N	Comments:

Inclusive Play Spaces



Reference

Sec. 2.3 Stairs
Sec. 2.4 Guards and Handrails
Sec. 2.8 Drinking Fountains
Sec. 3.1 Parking
Sec. 3.3 Exterior Paths of Travel
Sec. 4.5 Washrooms

Application

This section applies to play spaces designed for children. Play spaces can be located in a variety of public settings (e.g., parks, schools, childcare facilities, or community/recreation centres). Play spaces typically require consideration for accessibility features related to:

- the number and types of play structures, equipment, elements, and features provided;
- play areas surrounding the play structures; and
- site amenities and features surrounding the play space.

Criteria provided in this section are intended to summarize key features for inclusive play spaces and reference to applicable standards. Detailed planning and design are required for provision of inclusive play spaces.



Note

Inclusive play spaces ensure that children with disabilities have equal opportunities for peer interaction and development of socialization skills. They also provide an opportunity for parents with disabilities to interact with their children.

Consultation Requirements

When constructing new or redeveloping existing outdoor play spaces, consultation on the needs of children and caregivers with various disabilities must occur with:

- a) the public and persons with disabilities; and
- b) your local Accessibility Advisory Committee if available.



Note

Requirements related to the area surrounding or beyond the play space, including, but not limited to, parking lots, washrooms, drinking fountains, and recreation facilities, are referenced elsewhere in this document.

Design Requirements

When constructing new or redeveloping existing play spaces:

- a) incorporate accessibility features, such as sensory and active play components, for children and caregivers with various disabilities into the design of outdoor play spaces; and
- b) ensure that outdoor play spaces have ground surface that is firm, stable, and has impact-attenuating properties for injury prevention and sufficient clearance to provide children and caregivers with various disabilities the ability to move through, in, and around the outdoor play space.

Ensure that the design of inclusive play spaces and features meet the requirements of CAN / CSA Z614-14, Annex H, including:

- i. H.1 Scope;
- ii. H.2 Reference Publications;
- iii. H.3 Reference Definitions;
- iv. H.4 Play spaces (e.g., ground-level and elevated play components, accessible routes, transfer systems, play components and ground surfaces); and
- v. other applicable sections of these Standards, as required.



Summary of Key Design Considerations

The information in the following subsections is intended to highlight key considerations only, not detailed specifications. Refer to requirements of the Canadian Standards Association (CAN / CSA Z614-14, Annex H). This information is not intended to duplicate existing standards, but is focused on presenting best practices for accessibility.



Note

A level approach, gradually sloped route or ramps are examples of types of accessible entry/exit points to a play space.

Entry and Exit Points

Provide a minimum of two accessible ingress/egress points:

- that are located as part of an adjacent accessible route;
- that ensure that accessible connections provided to play space surfaces are firm, stable, and slip-resistant, as well as providing direct connections to individual play components; and
- provide clear width of 1525 mm (minimum).



An example of accessible entry / exit point and accessible route leading to elevated play components.

Accessible Routes

- provide at least one accessible route within the boundary of the play space, connecting ground-level play components and elevated play components, including entry and exit points of the play components;
- ensure that the clear width of an accessible route is 1 525 mm (minimum); and
- ensure that the maximum slope for an accessible route connecting ground-level play components within the boundary of a play space is 1:16 (6.25%).

Note

Refer to exceptions and detailed requirements, including gradient, clear width, and reduced width criteria, identified in CSA, Annex H.

Play Space Ground Surface

- provide accessible surface materials for play spaces such as poured-in-place rubber, accessible turf, rubber mats and tiles, bonded and engineered wood fibers or shredded rubber.



Play Components

- a) provide a high tonal contrast between a play component and its surroundings.

Elevated Play Components

An elevated play component is a play component reached from above or below grade, and is part of a composite play structure.

- a) ensure that at least 50% of elevated play components are connected to a ramp or transfer system, as identified in **Table 13**.

Total Number of Elevated Play Components	Total Percentage of Elevated Play Components Requiring Ramp or Transfer System
20 or more	50% minimum (25% ramp and 25% ramp or transfer system)
Less than 20	50% minimum (ramp or transfer system)

Table 13: Percentage of Elevated Play Components Required to be connected to Transfer Systems



Examples of elevated play components.

Transfer Systems

- a) provide transfer systems to connect elevated or ground-level play components (e.g., transfer steps or platforms);
- b) ensure transfer steps are used where movement is intended from a transfer platform to a level that provides elevated play components on an accessible route; and
- c) provide a minimum clear floor space of 915 mm wide by 1370 mm long adjacent to all transfer locations onto play components (**Figure 109**).

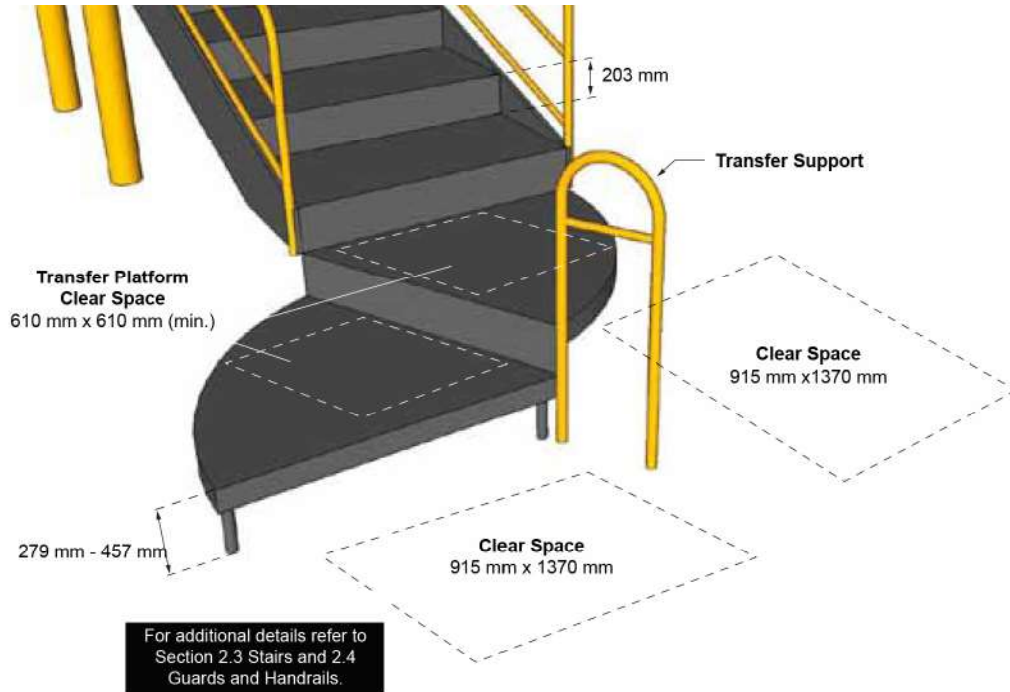

Figure 109: Transfer Systems



Best Practice

The distance covered by the transfer steps should be the shortest possible.



Note

A transfer platform is used where transfer is intended from a wheelchair or other mobility aid. Refer to detailed requirements, e.g., means of support and surface sizes, identified in CSA, Annex H.

Examples of supports include a rope loop, a loop-type handle, a slot in the edge of a flat horizontal or vertical member, poles or bars, or solid D-shaped rings affixed to corner posts.

Turning Space

- a) provide clear turning space for mobility aids of 1675 mm (preferred) or 1500 mm (minimum) diameter on the same level as play components.

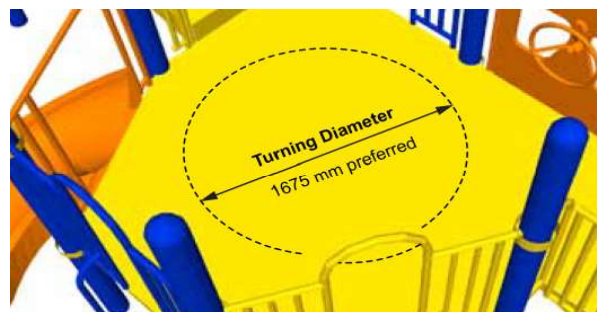

Ground Level Play Components

A ground-level play component is a play component that is approached and exited at the ground level. Provide the ratio of ground-level play component alternatives, compared to elevated play components, as identified in **Table 14**.

Number of Elevated Play Components provided	Minimum number of ground-level play components required to be on an accessible route	Minimum number of different types of ground-level play components required to be on an accessible route
1	n/a	n/a
2 to 4	1	1
5 to 7	2	2
8 to 10	3	3
11 to 13	4	3
14 to 16	5	3
17 to 19	6	3
20 to 22	7	4
23 to 25	8	4
	8 plus 1 for each additional 3 over 25, or fraction thereof	5

Table 14: Ground-Level Play Component Alternatives to Elevated Play Components
 Source: Canadian Standards Association (CAN / CSA Z614-14, Annex H)



Examples of ground-level play components.

Inclusive Play Space Design Guide



Reference

- Sec. 2.2 Ramps
- Sec. 2.3 Stairs
- Sec. 2.4 Guards and Handrails
- Sec. 2.8 Drinking Fountains
- Sec. 2.10 Seating, Tables and Work Surfaces
- Sec. 3.1 Parking
- Sec. 3.2 Passenger Loading Zones
- Sec. 3.3 Exterior Paths of Travel
- Sec. 4.5 Washrooms
- Sec. 5.7 Lighting

Application

This design guide is provided for use by City Staff when designing new inclusive play spaces.

How to Use the Guide

The Inclusive Play space Design Guide identifies key design features for planning and designing an inclusive play space, with a focus on the main accessibility features that are required to meet the diverse needs of users of all ages and abilities, including children using the play space as well as caregivers and companions. Additional design considerations may also be required related to the broader play space context and environment, including requirements for the site and park where the play space is located (e.g., seating and viewing areas for parents or caregivers). Overall, this Guide is intended to welcome and address the needs of children, caregivers and users of all age and abilities, emphasizing opportunities for inclusive and shared play.



Note

This guide does not provide all requirements for designing an inclusive play space; only key requirements are provided. Refer to Section 6.17, Inclusive Play Spaces of these Standards and CAN / CSA Z614-14 (Annex H), for more details.

Designing an Inclusive Play Space

Key Features of an Inclusive Play Space

Play spaces that offer children of all abilities the opportunity to interact and play with each other are essential to promoting diversity and inclusion.

The following diagram identifies important best practices when designing an inclusive play space.

Key features are indicated on the diagram and described in this guide.

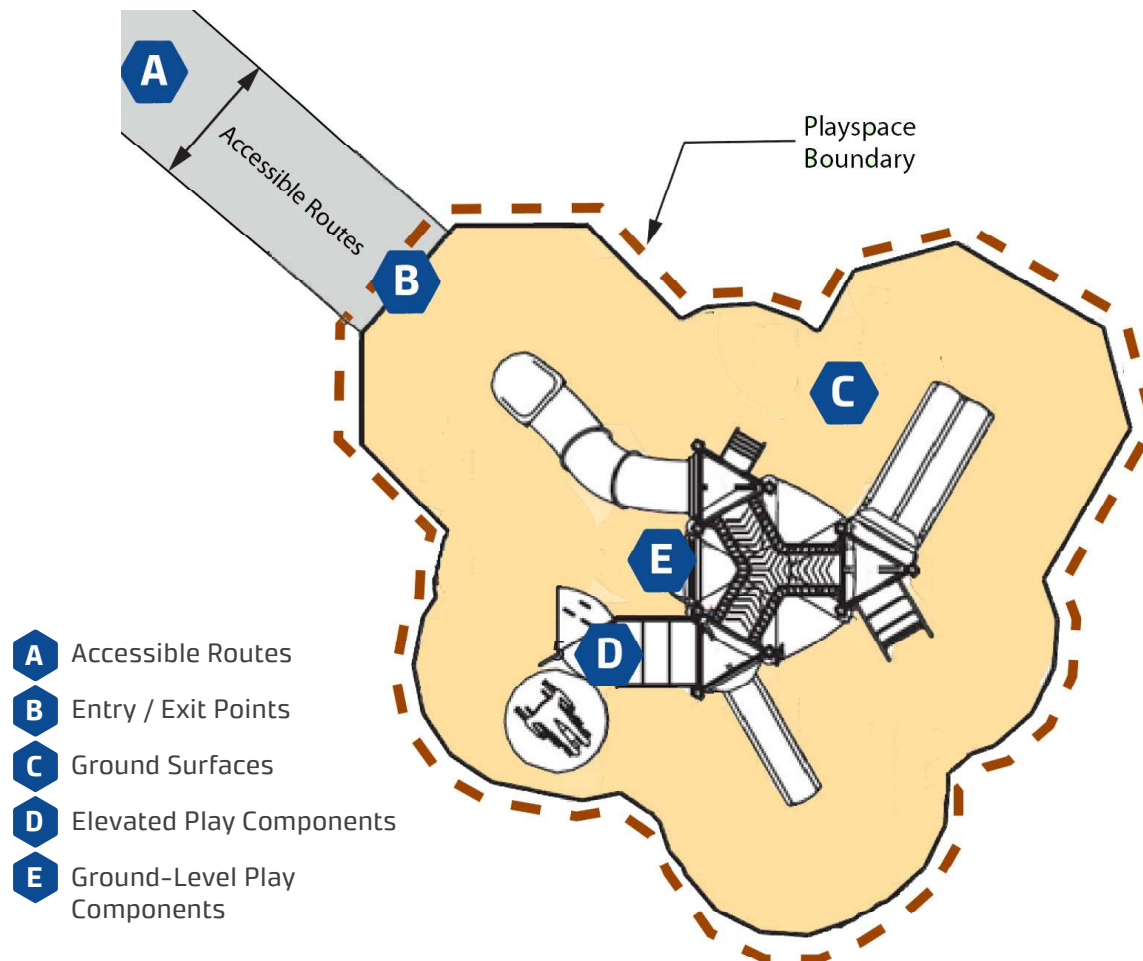

Note: Play spaces come in different shapes and sizes. This diagram is provided for guidance and reference only.

Summary of 5 Key Features

The following provides a summary of the 5 key design features when designing an inclusive play space.



Accessible Routes

Accessible route(s) connecting to the play space boundary from the parking lot, sidewalk and other adjacent routes and buildings are essential for easy access to the play space.

Key Consideration:

Is there at least one accessible route leading to the play space?



Accessible route connecting to play space.



Accessible route connecting to play space.



Entry / Exit Points

Entry / exit points from an accessible route along the boundary of the play space for users of mobility aids to access play components, where there is a change in level.

Key Consideration:

Is there at least one entry/exit point (2 or more preferred) into the play space?



Play space is at-grade with accessible route.



Curb ramp into play space where there is a level change between accessible route and play space.



Ground Surfaces

Surfacing is a key component in designing safe and accessible play spaces. Accessible surfaces include poured-in place rubber, shredded rubber and engineered wood fiber.

Key Consideration:

Is the play space ground surface accessible?



Shredded Rubber.



Engineered Wood Fiber.



Poured-in-Place Rubber.



Elevated Play Components

An **elevated play component** is a play component reached from above or below grade, and is part of a composite play structure.

Note: Ramps, transfer systems, steps, stand-alone slides, decks, and roofs are not considered elevated play components.

Two common methods for providing access to elevated play components are ramps and transfer systems.

Key Consideration:

Are at least 50% of elevated play components located on an accessible route and connected by a ramp or transfer system?



Example of play structure with elevated play components.



Example of play structure with elevated play components.



Ramp connected to elevated play components.



Transfer system to connect elevated play components.



Ground-Level Play Components

A **ground-level play component** is a play component that is approached and exited at ground level.

When designing an inclusive play space, one of the required design features is the provision of play components along the accessible routes for users who may not be able to access components located on elevated platforms.

The number and variety of ground-level play components required to be on an accessible route is determined by the number of elevated play components provided in the play space.

Key Consideration:

Are the minimum number and variety of ground-level play components along an accessible route provided?

Note: A calculator to determine the required number and variety of ground-level and elevated play components required in an inclusive play space is provided in CAN / CSA Z614-14, (Annex H).



Example of a ground-level play component.



Example of an accessible swing.

STEP-BY-STEP GUIDE ON APPLYING ANNEX H

Step-by-Step Guide

The following step-by-step guide has been provided to assist in evaluating a playspace for meeting the minimum requirements of Annex H. The guide has been arranged in two steps and provides spaces to fill in numeric values of play components for evaluating a specific playspace design.

Step 1) Total # Of Elevated Play Components =

Assess Present Situation	
Total # Of Components Along Accessible Route (answer = item "A")	Variety Of Play Types Along Accessible Route (answer = item "X")
Assess What Is Needed (from Table H.1)	
Min. # Of Ground Level Components Required Along Accessible Route (answer = item "B")	Variety Of Different Play Types Required Along Accessible Route (answer = item "Y")
How To Get There	
Total # Of Components To Be Added (item "B" minus item "A")	Total Variety Of Play Types To Be Added (item "Y" minus item "X")

*A negative number in the either bottom box means that there is more than the minimum number already on site

Step 2) Assess Access to Elevated Components

Total # of Elevated Components =

- If 20 or more components then ramps to 25% and ramp or transfer to an additional 25%
- If 19 or fewer components than transfer system or ramp to 50% of components

Courtesy of the Canadian Playground Safety Institute (cpsionline.ca) from the Online Accessibility Course.

Additional Considerations

Directions to be provided to play equipment supplier when selecting play equipment:

1. Provide age range and number of children using the play space;
2. Describe the vision for the proposed play space. Provide a Design Program which outlines the goals and objectives for the play space;
3. Describe the site context:-what is around the play area and how will it be used;
4. Provide a budget for the equipment, keeping in mind costs for landscaping and natural features;
5. Follow CAN/CSA Z614-14, Annex H accessibility standards and Section 6.17 Inclusive Play Spaces;and
6. Emphasize that equipment should fit into site plan, not vice versa.

Source: Adapted from “Let’s Play: Creating Accessible Playspaces: A Tool Kit for School-Based Groups”, Rick Hansen Foundation.

Inclusive Play Space Checklist

Application

The information in this Checklist is intended to assist with reviewing key design options for providing inclusive play spaces. Information in this checklist may be updated based on new design standards identified during implementation.

Use this Checklist when reviewing individual areas of each play space, depending on the overall layout, features, and type of equipment that is provided.



Note

Refer to Sections 6.17 Inclusive Play Spaces and 6.18 Inclusive Play Space Design Guide and CAN/CSA Z614-14 (Annex H) for detailed information and accessibility criteria when designing a new inclusive play space.

Inclusive Play Space Checklist

The following checklist is intended for use by City Staff when reviewing key design options for inclusive play spaces. The items in this Checklist are colour coded to match the information in Section 11.5 Inclusive Play Space Design Guide.

General Information

Reference (I.D # / Park Name): _____

Reviewed By

Name: _____

Identify Total Number of Play Areas or Zones:

Title / Position: _____

Department: _____

Play space type: Junior Senior Adventure Consideration Water Features

1. Key Design Consideration

1.1 Accessible Routes

1.1.1	Is there at least one (1) accessible route within the boundary of the play space?	<input type="checkbox"/> Y <input type="checkbox"/> N	Comments:
-------	---	---	-----------

1.2 Entry / Exit Points

1.2.1	Is there at least one (1) entry / exit point to the play space (2 or more preferred) connected to an accessible route?	<input type="checkbox"/> Y <input type="checkbox"/> N	Comments:
-------	--	---	-----------

1.3 Ground Surfaces

1.3.1	Is the play space ground surface accessible (specify surface type)? If yes, does ground surface material meet CSA standards for equipment and layout?	<input type="checkbox"/> Y <input type="checkbox"/> N	Comments:
-------	--	---	-----------

1.4 Elevated Play Components

1.4.1	Are at least 50% of elevated play components located on an accessible route and connected by a ramp or transfer system?	<input type="checkbox"/> Y <input type="checkbox"/> N	Comments:
-------	---	---	-----------

1.5 Ground-Level Play Components

1.5.1	Are the minimum number and variety of ground-level play components required to be along an accessible route provided? Note: Use calculator identified in CAN / CSA Z614-14 (Annex H) to determine required number of play components.	<input type="checkbox"/> Y <input type="checkbox"/> N	Comments:
-------	--	---	-----------

2. Additional Considerations

2.1	Are creative features that stimulate the senses provided (Examples include: water and sand features, scent gardens, wind chimes and winding pathways)? If yes, provide a description, including site context and amenities provided adjacent to play space or in the park.	<input type="checkbox"/> Y <input type="checkbox"/> N	Comments:
-----	---	---	-----------

2.2	Does play equipment foster inclusive play and allow children of all ages and abilities to be part of the action / activities? If yes, describe.	<input type="checkbox"/> Y <input type="checkbox"/> N	Comments:
-----	---	---	-----------

2.3	Does play space equipment meet accessibility requirements of CAN / CSA Z614-14 (Annex H)? Note: A detailed assessment may be required.	<input type="checkbox"/> Y <input type="checkbox"/> N	Comments:
-----	---	---	-----------

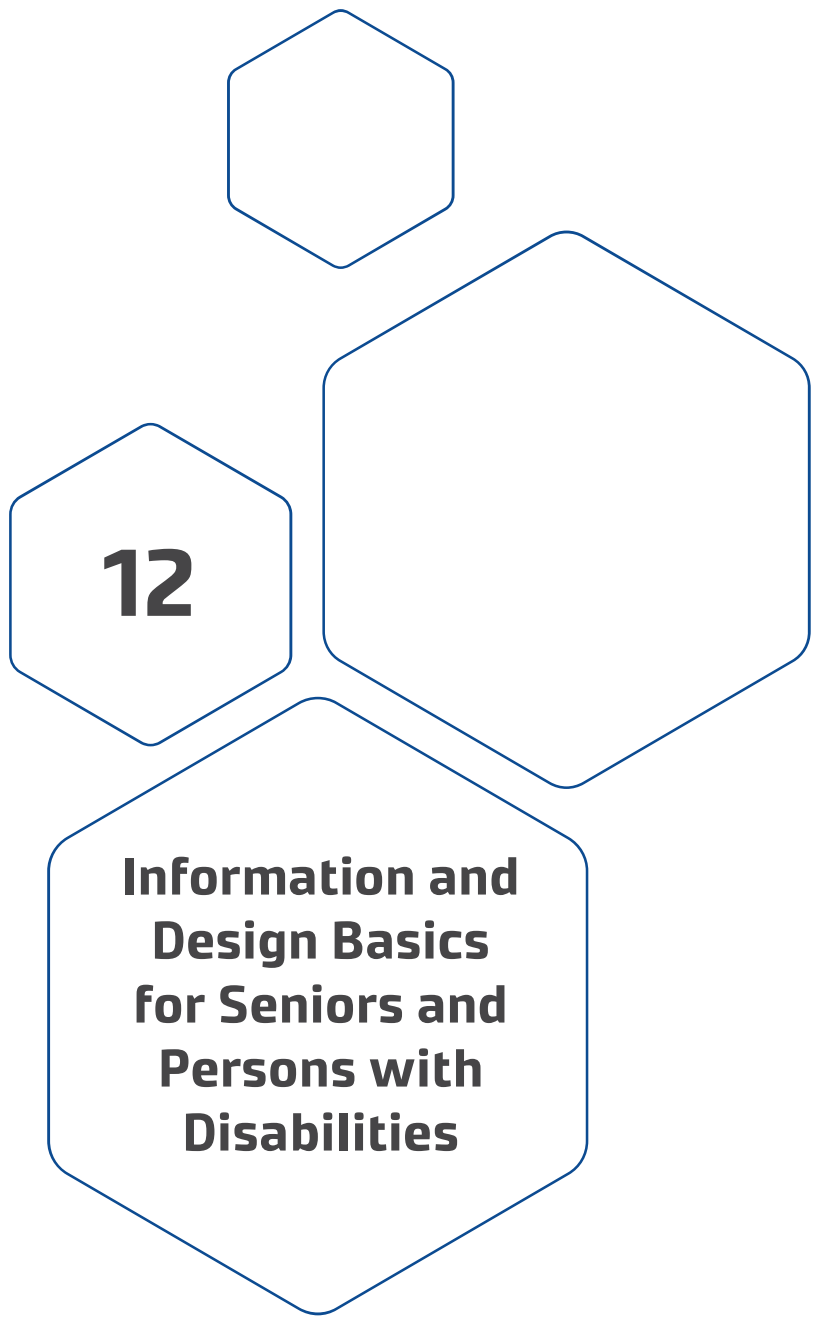

12

**Information and
Design Basics
for Seniors and
Persons with
Disabilities**

Information and Design Basics for Seniors and Persons with Disabilities

Canadians with visual disabilities is not a homogenous group, as there are many types and levels of eye conditions. For example, a person with an eye condition may require a dimly lit environment, when another person with a different eye condition may require intense lighting for functional living. The guidelines listed, therefore, reflect a well-researched average way of addressing related design issues to best accommodate people with these disabilities.

Effective barrier-free design for built-environment users with visual disabilities relies upon

- colour/contrast cues, which can be used to define building landmarks, help one identify obstacles in a path of travel, and assist with locating building controls such as light switches, thermostats and fire alarms;
- lighting, planned to enhance the intensity and distribution of artificial lighting sources while minimizing glare and backlit areas;
- auditory cues, which can help a person to map his/her environment through sounds, such as water fountains, music or public address systems;
- tactile and kinaesthetic cues, such as the application of different floor surfaces and approved tactile warning surfaces; and
- ergonomics, which can be applied to room arrangements with logical, effective furniture use, helping a person map his/her path of travel and avoid hazardous building zones.



Note

The design considerations are not mutually independent. The five areas are all necessary for effective design.

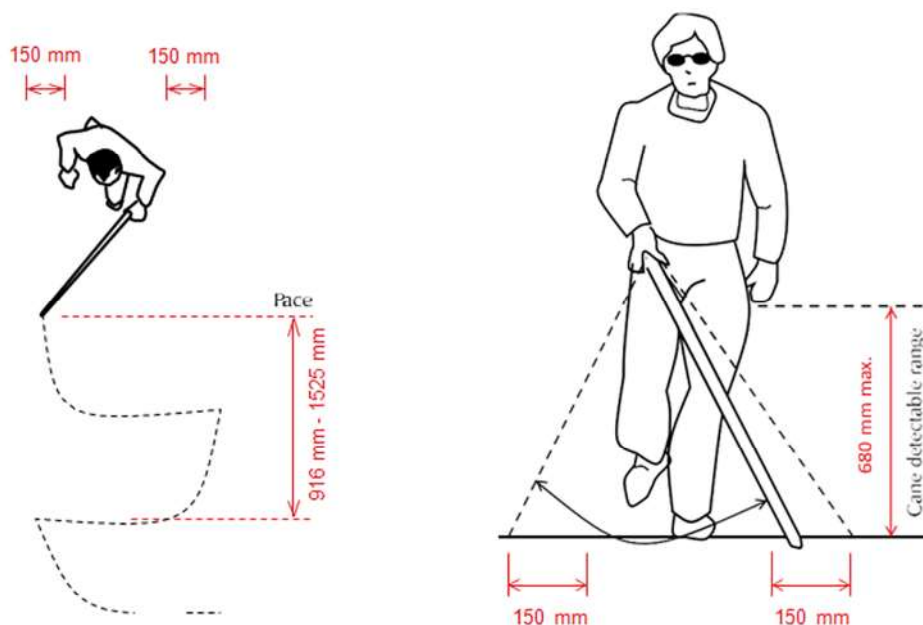

Barrier-Free Design Basics for People who are Deaf

A person who is deaf has little or no functional hearing and depends on visual communication such as sign language, reading, and writing. Since a person who is deaf cannot hear speech, s/he relies on visual cues such as a light to alert him/her of a ringing telephone, a doorbell, or an alarm. Individuals who are deaf require good lighting and open spaces because this allows them to view their surroundings. An open layout designed with as few walls, wall dividers, and columns as possible will increase the ability of these individuals to scan an area.

Barrier-Free Design Basics for People who are Deaf-Blind

Those who are deaf-blind have a dual disability. Many of these individuals retain some varying and limited degree of either hearing or sight. They often rely more upon their kinesthetic senses (e.g., touch, heat, pressure) to function within built environments. Building designs that benefit people with visual disabilities as well as those who are hard of hearing or deaf are also often beneficial to deaf-blind populations.

Barrier-Free Design Basics for People who are Hard of Hearing

As with people who have a loss of vision, those with hearing loss are not a homogeneous group. There is a broad spectrum of hearing loss, including those with hearing loss that comes on late in life. A hard-of-hearing person relies on visual cues, such as light signals and captions. Open designs with non-glare surfaces are most suitable.

Barrier-Free Design Basics for People with Communication and Cognitive Disabilities

Communication disabilities (such as aphasia, i.e., difficulty talking, understanding, reading and/or writing) can result after injury to the brain (such as a stroke). Signs with simple pictures and with written information limited to short, simple concepts are important for this group. People with communication disabilities may also benefit from the use of design considerations for those with visual disabilities (e.g., colour/contrast, lighting, auditory, tactile/kinaesthetic and ergonomic cues). People with communication disabilities may or may not also have mobility issues.

These listed considerations and solutions are similar for people with cognitive disabilities.

Barrier-Free Design Basics for Seniors

The majority of seniors (those 65 and over) may be subject to some form of age-related change in their abilities, such as loss of vision, loss of hearing, arthritis, stroke, or hip or knee replacement. Some of these factors may create mobility limitations, creating an increase in the number of people who rely on mobility devices such as walkers, wheelchairs or power scooters to get around. In addition to space for these tools, lighting and auditory levels may need to be addressed in order for some seniors to function independently and safely.

Barrier-Free Design Basics for People Using Mobility Devices

People who experience decreased hand and finger dexterity; limited ranges of motion; decreases in strength, balance or co-ordination; or fatigue may require the use of a mobility device, such as a walker, cane, brace, crutch, wheelchair or scooter. These devices require ease of access to buildings and all facilities and services. This includes a barrier-free safe path of travel, accessible entrances (preferably at zero grade with powered doors), accessible washrooms and stalls, access to paper towels and soap dispensers, lever handles, larger handles on locking devices, and a turning radius to accommodate wheelchairs or scooters. These adaptations also benefit parents with strollers, delivery people and those manoeuvring presentation materials.

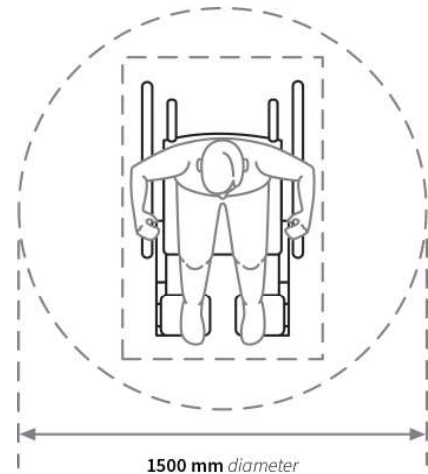

Environmental Design Considerations for the Bariatric Population

Considerations must be made for the growing population of severely obese and bariatric individuals in Canada. In general, bariatric individuals can be described by any of the following: overweight by greater than 100-200 lbs, a body weight greater than 300 lbs, and/or a BMI greater than 40. Individuals who are severely or morbidly obese (bariatric) are at greater risk for many disabling conditions, such as stroke, diabetes, cancer, reduced respiratory function, etc. They also experience decreased mobility and less independence in daily activities due to obesity itself.

Current basic building standards are not adequate to accommodate individuals who are severely and morbidly obese and who rely on mobility aids such as larger, bariatric four-wheeled walkers, wheelchairs, and scooters. Doorways and hallways are too narrow, stairs are very difficult to negotiate, and turning radii are too small.

Bathrooms/Showers

- Avoid use of wall-mounted toilets.
- Use bariatric floor-mounted toilets that are rated to 450 kg. CAUTION: Bariatric toilets are deeper and wider, and may have a higher seat height, making it difficult for the bariatric individual to use, especially if of shorter stature.
- Use a bariatric commode over a standard toilet, if not using a bariatric toilet. The seat height can be adjusted to fit the individual's needs. A floor-mounted toilet with an unattached flush tank has more options for use with various bariatric commodes.
- Have a minimum distance of 530 mm between the toilet and the flanking wall. A greater distance may be indicated if assistance from caregivers and/or larger equipment is required.
- Locate toilets so that they can be accessed by moving sideways rather than twisting and making a 90° or 180° turn.
- Have a clear width of approach of at least 1140 mm for urinals in order to accommodate individuals using wider wheelchairs.
- Avoid floor sinks, as they interfere with wheelchairs. Instead, provide extra support to wall-mounted sinks/counters.

- Allow a larger turning radius for individuals using wheelchairs. A recommended 1 900 mm turning radius for wheelchairs or commodes and a caregiver is suggested.
- Ensure that wall-mounted grab bars are structurally reinforced and rated to handle 4.5 kN (454 kg). They should also be mounted further forward from the back wall.
- Mount toilet tissue dispensers sufficiently in front of the toilet to allow ease of access and to prevent interference with grab bar use.
- Use texture-tiled open showers with floor drains. Avoid enclosing walls; instead, use shower curtains to allow for ease of access and assistance by caregivers, if needed.
- Include multiple, reinforced grab bars (rated for at least 4.5 kN (454 kg)) for showers. The grab bars must be located so that they can be reached by a user who is obese.
- Ensure that the dimensions of private showers are at least 1 500 mm × 1 500 mm. If assistance is required, the dimensions should be greater to accommodate the caregiver (i.e., 1 830 mm × 1 500 mm or greater).
- Incorporate a removable shower head. A bariatric shower seat/commode may also be necessary.
- Avoid curbs into accessible showers.
- A wet room may be appropriate in lieu of a separate shower in the bathroom.

What are the features of a wet room?

The main way in which wet rooms differ from traditional bathrooms is that rather than having a built-in, enclosed shower cubicle, the room itself effectively acts as the enclosure. This means that wet rooms have to be fully waterproofed to prevent leaks.

In terms of bathroom suites, there is a wide range of options to choose from; the only difference is that you don't necessarily need to worry about choosing a shower screen as you would with other types of bathroom. Many wet rooms are also tiled from floor to ceiling to take care of the issue of waterproofing, and drainage is another important issue to consider.

Why are they popular?

One of the main reasons wet rooms are popular is because they can help you to save space if you only have a small bathroom. They mean that you don't need to have a shower cubicle, which can constrict movement in a small room, and you don't even need to have a bath in there if you don't want to.

Wet rooms are also very practical, particularly for people with mobility issues, as they eliminate the need to step up into a shower cubicle. They are also considered to be very stylish, so if you want to create a "cool," modern look in your bathroom, they could be a good option to consider. With the increasing range of bathroom suites available, there are plenty of designs to choose from, so you should be able to create exactly the look you want.

Another reason many people like wet rooms is that they can be easier to clean, due to the fact there are fewer fiddly surfaces and corners to worry about.

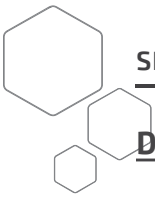

Doorways/Corridors/Elevators

- Ensure that doorways have a minimum clearance of 1 140 mm. This clearance can accommodate an individual in a wheelchair with a total width of 990 mm (approximately 760 mm seat width), with 76 mm clearance on either side.
- Consider that the use of oversized equipment may require a door clearance larger than 1 140 mm. A larger door width can be accomplished by using unequal-leaf swing doors. For example, one leaf might be 1 066 mm and the other 457 mm for an overall width of 1 524 mm, which would accommodate a bariatric hospital bed. Other ways to maximize door clearance include the use of pocket doors, folding doors and offset hinges.
- Increase the width of corridors/hallways to accommodate larger girth and equipment. An 890 mm corridor accommodates a user with a 711 mm bariatric walker. A 1 500 mm-wide corridor allows for one person who is obese and using a walker and one person of regular size and no equipment to pass. If passage of larger equipment is required (e.g., a bariatric wheelchair), hallways wider than
- 1 500 mm (i.e., 1 830 mm or more) should be considered to allow passage and the turning of wheelchairs.
- Make elevator door clearances as large as possible (and a minimum of 1 140 mm). The interior dimensions should be a minimum of 1 828 mm × 2 032 mm to allow for a larger turning radius of the wheelchairs and the transportation of a stretcher with two caregivers (e.g., for emergency services).

Accessible Entrances/Ramps

- Use ramps that have a minimum unobstructed width of 1 140 mm to allow for larger wheelchair widths and clearance for individuals to propel the wheelchair.
- Use a gradient of 1 in 20 because of the increased weight of the individual who is obese, considering that self-propulsion and/or caregiver effort when pushing the wheelchair will be greater.
- Have a minimum 1 500 mm × 1 500 mm level area where a ramp makes a 90° or 180° turn, and at intermediate levels as required in longer ramps.
- Ensure that curb cutouts and openings are at least 1 140 mm wide to accommodate larger wheelchair widths.
- Ensure that doorways located in a barrier-free path of travel have a minimum clearance of 1 140 mm
- If a door swings open toward the wheelchair user, increase the clear space on the latch side of door to a minimum of 760 mm to allow for the increased turning radius of larger wheelchairs.
- Where a doorway or stairway empties onto a ramp through an end wall, have a level area extending across the full width of the ramp (e.g., 1 140 mm) and along its length for not less than 1 500 mm.
- Increase load values for handrails so that they can withstand the increased weight of individuals who are obese. Recommend construction to withstand a minimum of 4.5 kN (454 kg) applied at any point and in any direction and a uniform load of 3.3 kN (340 kg) applied in any direction to handrails located outside of dwelling units.

Bedrooms/Private Spaces

- Have 1 500 mm of clearance available around the bed of an obese individual to allow room for caregiver assistance, equipment such as wheelchairs and walkers, and space for lifts to be manoeuvred beside the bed.
- Have grab bars rated for at least 454 kg placed strategically from bed to toilet to allow increased independence with toileting.
- Consider space for oversized furniture and storage of oversized equipment (i.e., 1 sq m for a portable lift, 370 sq m for a walker, 1.5 sq m for a wheelchair, 465 sq mm for a commode).
- Consider that individuals who are obese are sensitive to ambient temperatures. Recommend strategies to help them control temperature in personal spaces, e.g., increase air conditioning capacity, allow access to temperature controls, and/or add a ceiling fan or portable fan.

For further information on bariatrics, please contact:

Giselle Tupper, BScOT
Professional Practice Leader
Supportive Living, Capital Health
(780) 735-3726
giselle.tupper@ahs.ca

Blair Mah, BScOT
Musculoskeletal Services
Glenrose Rehabilitation Hospital
(780) 735-7999
blair.mah@ahs.ca

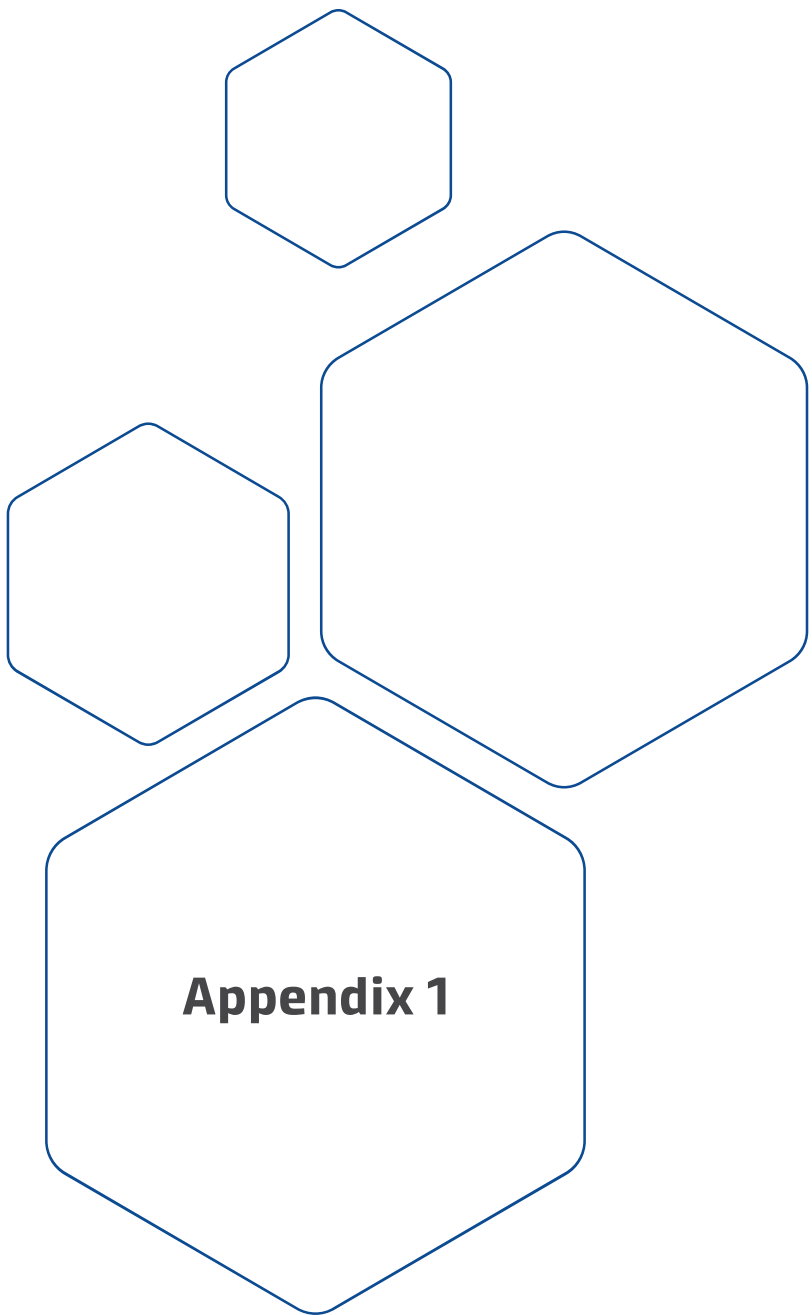

Appendix 1

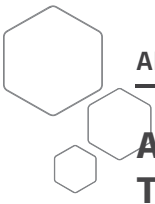

APPENDIX 1

The Principles Of Universal Design

Universal design is the design of products and environments to be usable by all people, to the greatest extent possible, without the need for adaptation or specialized design.

PRINCIPLE ONE: Equitable Use

The design should be useful and marketable to people with diverse abilities.

Guidelines:

- Provide the same means of use for all users: identical whenever possible; equivalent when not.
- Avoid segregating or stigmatizing any users.
- Allow provisions for privacy, security, and safety that are equally available to all users.
- Make the design appealing to all users.

PRINCIPLE TWO: Flexibility in Use

The design should accommodate a wide range of individual preferences and abilities.

Guidelines:

- Provide choice in methods of use.
- Accommodate right- or left-handed access and use.
- Adapt to user's accuracy and precision.
- Provide adaptability to the user's pace.

PRINCIPLE THREE: Simple and Intuitive Use

Use of the design is easy to understand, regardless of the user's experience, knowledge, language skills, or current concentration level.

Guidelines:

- Eliminate unnecessary complexity.
- Be consistent with user expectations and intuition.
- Accommodate a wide range of literacy and language skills.
- Arrange information consistent with its importance.
- Provide effective prompting and feedback during and after task completion.

PRINCIPLE FOUR: Perceptible Information

The design communicates necessary information effectively to the user, regardless of ambient conditions or the user's sensory abilities.

Guidelines:

- Use different modes (e.g., pictorial, verbal, tactile) for redundant presentation of essential information.
- Provide adequate contrast between essential information and its surroundings.

- Maximize legibility of essential information.
- Differentiate elements in ways that can be described (in order to make it easy to give instructions or directions).
- Provide compatibility with a variety of techniques or devices used by people with sensory limitations.

PRINCIPLE FIVE: Tolerance for Error

The design minimizes hazards and the adverse consequences of accidental or unintended actions.

Guidelines:

- Arrange elements to minimize hazards and errors: most used elements, most accessible; hazardous elements eliminated, isolated, or shielded.
- Provide warnings of hazards and errors.
- Provide fail-safe features.
- Discourage unconscious actions in tasks that require vigilance.

PRINCIPLE SIX: Low Physical Effort

The design can be used efficiently and comfortably and with a minimum of fatigue.

Guidelines:

- Allow users to maintain neutral body position.
- Use reasonable operating forces.
- Minimize repetitive actions.
- Minimize sustained physical effort.

PRINCIPLE SEVEN: Size and Space for Approach and Use

Appropriate size and space is provided for approach, reach, manipulation, and use, regardless of user's body size, posture, or mobility.

Guidelines:

- Provide a clear line of sight to important elements for any seated or standing user.
- Make reach to all components comfortable for any seated or standing user.
- Accommodate variations in hand and grip size.
- Provide adequate space for the use of assistive devices or personal assistance.

Please note that the Principles of Universal Design address only universally usable design, while the practice of design involves more than considerations for usability. Designers should also incorporate other considerations, such as economic, engineering, cultural, gender, and environmental concerns, into design processes. These principles offer designers guidance to better integrate features that meet the needs of as many users as possible.

Compiled by advocates of universal design, listed in alphabetical order:

Bettye Rose Connell, Mike Jones, Ron Mace, Jim Mueller, Abir Mullick, Elaine Ostroff, Jon Sanford, Ed Steinfeld, Molly Story and Gregg Vanderheiden.

Major funding provided by The National Institute on Disability and Rehabilitation Research, US Department of Education.

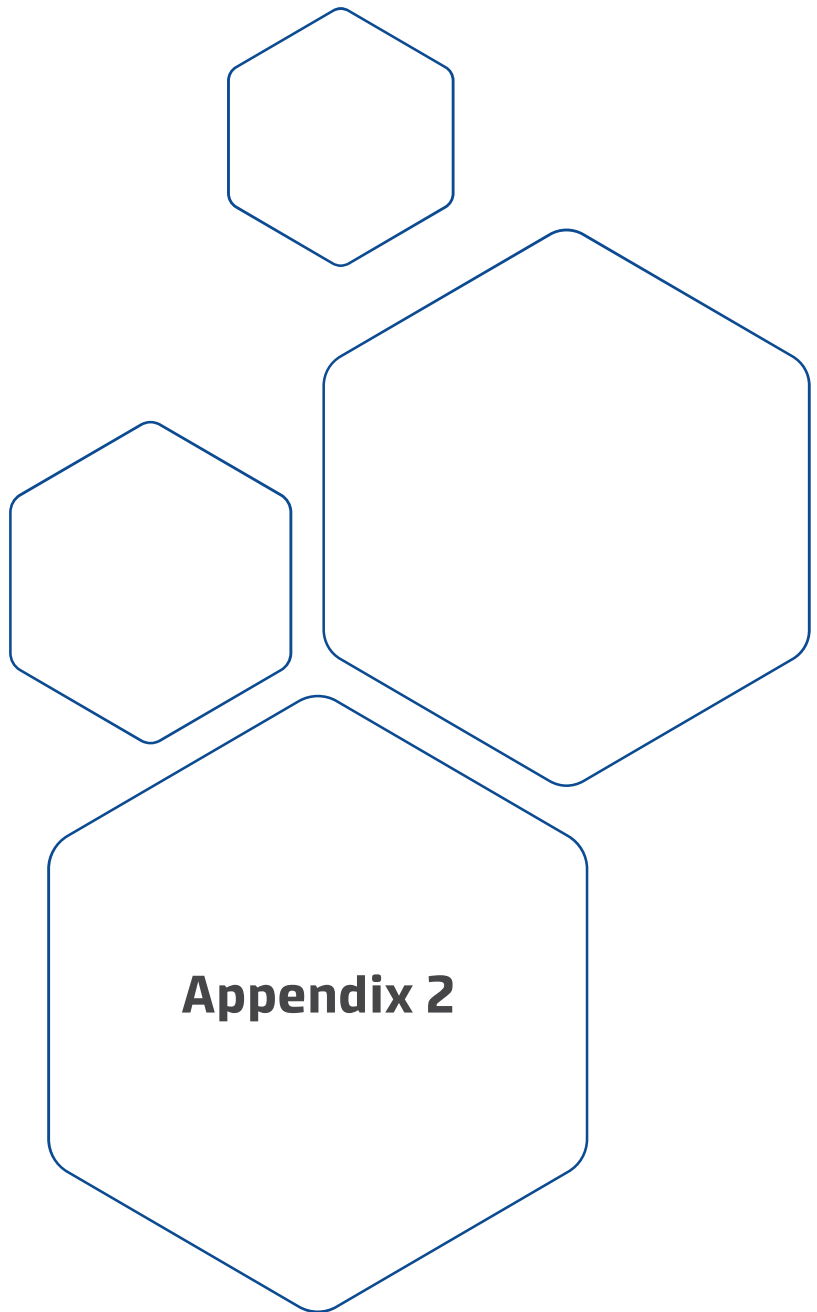

Appendix 2

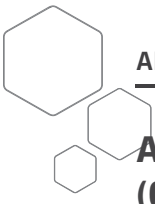

APPENDIX 2 (CSA) NON-MANDATORY APPENDIX E-ELEVATOR REQUIREMENTS FOR PERSONS WITH PHYSICAL DISABILITIES (APPLICABLE TO THE CSA B44 ONLY)

E.1 Scope

This appendix contains requirements intended to make passenger elevators usable by persons with physical disabilities. These requirements are in addition to, or modifications of, certain requirements specified elsewhere in this standard.

E.2 Operation and levelling

Elevator operation shall be automatic. Each car shall be equipped with a self-levelling feature that will automatically bring and maintain the car at floor landings within a tolerance of ± 13 mm under rated loading to zero loading conditions.

E.3 Door operation

Power-operated, horizontally sliding car and landing doors opened and closed by automatic means shall be provided.

E.4 Door size

The clear width of elevator doors shall comply with Table E-1.

E.5

E.5.1 Door protective and reopening device

Doors shall be provided with a door-reopening device that will function to stop and reopen a car door and an adjacent landing door to at least 910 mm, in case the car door is obstructed while closing. This reopening device shall also be capable of sensing an object or person in the path of a closing door at a nominal 125 mm ± 25 and 735 mm ± 25 mm above the floor without requiring contact for activation.

E.5.2

Door-reopening devices shall remain effective for a period of not less than 20 seconds.

E.6 Door timing for hall and car calls

From the time the doors start to open, a minimum period of 5 seconds shall elapse before the doors start to close if it is a hall call, and 3 seconds if it is a car call. A reduction of this time shall be permitted after operation of the door-close button.

E.7 Inside dimensions of elevator cars

The inside dimensions of elevator cars shall comply with Table E-1.

Table E-1				
Minimum dimensions of elevator cars in millimetres				
Door location	Door clear width mm	Inside car, side to side, mm	Inside car, back wall to front return, mm	Inside car, back wall to inside face of door, mm
Centered	1065	2030	1295	1370
Side (off-centre)	9152	1725	1295	1370
Any	9152	1370	2030	2030
Any	9152	1525	1525	1525
Minimum Diameter of LU/LA (Limited Use/Limited Application) Elevators				
Any	815	1065	1370	Not specified

Notes:

- (1) Table E-1 is based on Table 407.2.8 in ANSI/ICC A117.1, metric values only.
- (2) A tolerance of minus 16 mm shall be permitted.

E.8 Car controls

E.8.1

Car controls shall have the features specified in Clauses E.8.2 to E.8.7.

E.8.2 Clear floor space

A clear floor space of 760 mm × 1 220 mm minimum shall be provided at the controls.

E.8.3 Height

Buttons with floor designations shall be located a maximum of 1 220 mm above the floor or ground measured to the centre line of the buttons, except that when the elevator serves more than 16 openings and parallel approach is provided, the location of buttons with floor designations, a maximum of 1 370 mm above the floor shall be permitted. Emergency controls, including the emergency alarm, shall be grouped at the bottom of the panel. Emergency control buttons have their centre lines 890 mm minimum above the floor or ground.

E.8.4 Buttons

E.8.4.1 Button dimensions

Buttons shall be $\frac{3}{4}$ in. (19 mm) minimum in their smallest dimension. Buttons or surrounding button collars shall be raised a minimum 1.5 mm.

E.8.4.2 Button arrangement

Except where provided in a standard telephone keypad arrangement, buttons shall be

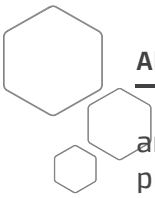

arranged with numbers in ascending order. When two or more columns of buttons are provided, they shall read from left to right.

E.8.4.3 Button designations

Except where provided in a standard telephone keypad arrangement, control buttons shall be identified by tactile characters complying with Clause E.19. Tactile characters and Braille shall be placed immediately to the left of the button to which they apply.

E.8.4.4

The control button for the main entry floor, and control buttons other than remaining buttons with floor designations, shall be identified with tactile and visual symbols as shown in Table 2.26.12.1.

Exception: The location and size of Braille, where required, shall comply with Table 2.26.12.1. (English shown for reference only.)

E.8.4.5

Buttons with floor designations shall be provided with visible indicators to show that a call has been registered. The visible indication shall extinguish when the car arrives at the designated floor.

E.8.5 Telephone-style keypads

Telephone-style keypads shall be a standard telephone keypad arrangement. Call buttons shall be 19 mm in their smallest dimension. Buttons shall be raised a minimum of 1.5 mm. Braille is not required. Characters shall be 13 mm in height and otherwise conform to E.19.4. The number five key shall have a single-raised dot. The dot shall be 3.0 mm to 3.05 mm base diameter and in other aspects conform to Table E-19.5. Characters shall be centred on the corresponding keypad button. A display shall be provided in the car with visible indicators to show registered car destinations. The visible indication shall extinguish when the call has been answered. A standard five-pointed star shall be used to indicate the main entry floor.



See Appendix 3

As Canada and Alberta construct more large multi-storey structures, a telephone-style keypad arrangement for in-car controls will become more prevalent and will eliminate any awkwardness by users with visual disabilities.

E.9 Car position indicators

E.9.1 General

In elevator cars, both audible and visible car floor location indicators shall be provided to identify the floor location of the car.

E.9.2 Visible

Indicators shall be located above the car control panel or above the door. Numerals shall be 16 mm in height.

E.9.3 Audible

The audible signal shall be 10 dBA minimum above ambient, but shall not exceed 80 dBA maximum, as measured at the annunciator. The signal shall be an automatic verbal announcement that announces the floor at which the car has stopped, except for elevators that have a rated speed of 1 m/s or less, in which an audible signal with a frequency of 1 500 Hz maximum sounds as the car passes or stops at a floor served by the elevator shall be permitted.

E.10 Emergency communications

E.10.1

Emergency two-way communication systems between the elevator car and a point outside the hoistway shall comply with 2.27.1. The highest operable part of a two-way communication system shall be located a maximum of 1 220 mm from the floor. If the device is located in a closed compartment, the compartment door hardware shall be operable with one hand and shall not require tight grasping, pinching, or twisting of the wrist. The force required to activate operable parts shall be 22.2 N maximum.

E.10.2

The device shall be identified by a symbol. The identification shall be a telephone located adjacent to the device or located on the compartment door if the device is located in a closed compartment. If the system uses a handset, the cord from the panel to the handset shall have a minimum length of 900 mm. The telephone, where provided, shall be equipped with a receiver that generates a magnetic field in the area of the receiver cap, and the telephone shall have a volume control and comply with CSA CAN3-T515.

E.10.3 Emergency signalling device

The car emergency signalling device shall not be limited to voice communication. If instructions for use are provided, essential information shall be presented in both tactile and visual forms.

E.11 Floor surfaces

Floor surfaces in elevator cars shall be firm, stable, and skid-resistant, permitting easy movement of wheelchairs. Carpet pile height shall be 13 mm maximum.

E.12 Handrails

Handrails shall be provided on all non-access walls. The top of the gripping surfaces of the handrails shall be at a height of 800 mm to 920 mm, with a space of 35 mm to 45 mm between the handrails and wall.

E.13 Illumination levels

The level of illumination at the car controls, platform, car threshold, and landing sill shall be 100 lx minimum.

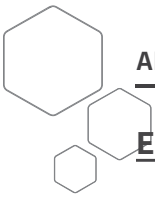

E.14 Hall Buttons

E.14.1

Hall buttons in elevator lobbies and halls shall be located vertically between 890 mm and 1 220 mm above the floor, measured to the centre line of the respective button.

E.14.2

A clear floor space of 760 mm × 1 220 mm minimum shall be provided at the hall buttons.

E.14.3

Hall buttons shall be 19 mm minimum in the smallest dimension.

E.14.4

Hall buttons shall have visual signals to indicate when each call is registered and when each call is answered.

E.14.5

The hall button that designates the UP direction shall be located above the button that designates the DOWN direction. Buttons or surrounding button collars shall be raised a minimum of 1.5 mm. Objects located beneath hall buttons shall protrude 25 mm maximum.

E.15 Hall or in-car signals

E.15.1

A visible and audible signal shall be provided at each hoistway entrance to indicate which car is answering a call and its direction of travel, except that signals in cars, visible from the floor area adjacent to the hall call buttons, and complying with requirements of Clauses E.15.2 and E.15.3, shall be permitted.

E.15.2 Audible signals

Audible signals shall sound once for the UP and twice for the DOWN direction, or shall have verbal annunciators that state the word UP or DOWN. Audible signals shall have a frequency of 1 500 Hz maximum. The audible signal or verbal annunciator shall be 10 dBA above ambient but shall not exceed 80 dBA above maximum, measured at the hall call button.

E.15.3 Visible signals

E.15.3.1 Height

Hall fixture signals shall be 1 830 mm minimum above the floor or ground, measured to the centre line of the fixture.

E.15.3.2 Size

The visible signal elements shall be 60 mm minimum in the smallest dimension.

E.15.3.3 Visibility

Signals shall be visible from the floor area adjacent to the hall button.

E.16 Floor/car designations

Raised character and Braille floor designations shall be provided on both jambs of elevator hoistway entrances and shall be centred at 1 525 mm above the floor, measured from the baseline of the characters. A raised star placed immediately to the left of the floor designation shall also be provided on both jambs at the main entry level. Such characters shall be 50 mm high and comply with Clause E.19.2.

E.17 Destination-oriented elevators

E.17.1 General

Destination-oriented elevators shall comply with Clauses E.2 to E.7, E.10, E.11, E.13, E.16 and E.17.2 to E.17.6.

E.17.2 Call buttons

Call buttons shall be 890 mm minimum and 1 220 mm maximum above the floor or ground, measured to the centre line of the buttons. A clear floor or ground space of 760 mm × 1 220 mm shall be provided. Call buttons shall be 19 mm minimum in their smallest dimension. Buttons shall be raised a minimum of 1.5 mm. Objects beneath hall call buttons shall protrude 25 mm maximum into the clear floor or ground space. Destination-oriented elevator systems shall have a keypad or other means for the entry of destination information. Keypads, if provided, shall be in a standard telephone keypad arrangement, and buttons shall be identified by characters complying with Clause E.19.4. Characters shall be centred on the corresponding keypad button. The number five key shall have a single raised dot. The dot shall be 3.0 mm to 3.05 mm base diameter, and in other aspects comply with Table E-19.5. Destination-oriented elevator systems shall be provided with visual and audible signals that indicate which elevator car to enter. The audible signal shall be activated by pressing the function button. The function button shall be identified by the international symbol for accessibility (see Figure E-19.2.6.1). The symbol shall be 16 mm in height. The function button shall be located immediately below the keypad arrangement or floor buttons. A display shall be provided in the car with visible indicators to show registered car destinations.

E.17.3 Hall signals

E.17.3.1 General

A visible and audible signal shall be provided to indicate a car destination in accordance with Clause E.17.2. The audible tone and verbal announcement shall be the same as those given at the call button or call button keypad, if provided. Each elevator in a bank shall have an audible and visible means for differentiation.

E.17.3.2 Visible signals

E.17.3.2.1 Height

Hall signal fixtures shall be 1 830 mm minimum above the floor or ground, measured to the centre line of the fixture.

E.17.3.2.2 Size

The visible signal elements shall be 60 mm minimum in their smallest dimension.

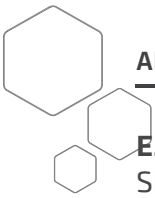

E.17.3.2.3 Visibility

Signals shall be visible from the floor area adjacent to the hoistway entrance.

E.17.4 Car controls

Emergency controls, including the emergency alarm, shall have centre lines that are 890 mm minimum and 1 220 mm maximum above the floor or ground. Buttons shall be 19 mm minimum in their smallest dimension. Buttons shall be raised a minimum of 1.5 mm. A clear floor space of 760 mm × 1 220 mm minimum shall be provided at the controls.

E.17.5 Car position indicators

E.17.5.1 General

In elevator cars, audible and visible car location indicators shall be provided.

E.17.5.2 Visible indicators

Indicators shall be above the car control panel or above the door. Numerals shall be 16 mm high minimum. As the car passes or stops at a floor served by the elevator, the corresponding character shall illuminate. The visible indicators shall extinguish when the car arrives at the designated floor.

E.17.5.3 Audible indicators

An automatic verbal announcement that announces the floor at which the car has stopped shall be provided. The announcement shall be 10 dBA minimum above ambient and 80 dBA maximum, measured at the annunciator.

E.17.6 Elevator car identification

In addition to the tactile signs required by Clause E16, a tactile elevator car identification shall be placed immediately below the hoistway entrance floor designation. The characters shall be 50 mm high and shall comply with Clause E.19.2.

E.18 Limited-use/limited-application elevators

Limited use/limited-application elevators shall comply with Clauses E.1 to E.17.

E.19 Signs

E.19.1 General

Signs that are required to be tactile, visual, or both shall comply with Clauses E.19.2 to E.19.7.

E.19.2 Characters that are both tactile and visual

E.19.2.1 General

Characters required to be tactile shall comply with Clauses E.19.2.2 to E.19.2.6. Tactile characters shall be duplicated in Braille in accordance with Clause E.19.5, except for tactile characters complying with Clause E.19.3, where separate visual characters with duplicate information complying with Clause E.19.4 are provided.

E.19.2.2 Finish and contrast

Characters and their background shall have a non-glare finish. Characters shall contrast with their background: either light characters shall appear on a dark background or dark characters shall appear on a light background.

E.19.2.3 Tactile character depth

Tactile characters shall be raised a minimum of 0.8 mm above the background.

E.19.2.4 Character forms

E.19.2.4.1

Fonts shall have characters complying with Clauses E.19.2.4.2 to E.19.2.4.7.

E.19.2.4.2 Case

Characters shall be uppercase.

E.19.2.4.3 Style

Characters shall be sans serif. Characters shall not be italic, oblique, script, highly decorative, or of other unusual form.

E.19.2.4.4 Width

Character width shall be 55% minimum and 110% maximum of the height of the character, with the width based on the uppercase letter O and the height based on the uppercase letter I.

E.19.2.4.5 Stroke thickness

Characters with rectangular cross-sections shall have a stroke thickness that is 10% minimum and 15% maximum of the height of the character, based on the uppercase letter I. Characters with other cross-sections shall have a stroke thickness at the base of the cross-sections that is 10% minimum and 30% maximum of the height of the character, and a stroke thickness at the top of the cross-section that is 15% maximum of the height of the character, based on the uppercase letter I.

E.19.2.4.6 Spacing

Where characters have rectangular cross-sections, spacing between individual characters shall be 3 mm minimum to 10 mm maximum. Where characters have other cross-sections, spacing between individual characters shall be 2 mm minimum to 10 mm maximum at the base of the cross-sections and 3 mm minimum to 10 mm maximum at the top of the cross-sections. Spacing shall be measured between the baselines of separate lines of characters and shall be 135% minimum to 170% maximum of the character height.

E.19.2.4.7 Height

Character height, measured vertically from the baseline of the character, shall be 16 mm minimum and 51 mm maximum based on the uppercase letter I.

E.19.2.5 Mounting height

Characters shall be located 1 220 mm minimum and 1 525 mm maximum above the adjacent floor or ground surface, measured from the baseline of the characters, except for elevator car controls.



E.19.2.6 Mounting location

Where a sign containing tactile characters is provided at a door, the sign shall be located alongside the door on the latch side. Where a tactile sign is provided at double doors, the sign shall be located to the right of the right-hand door. Where there is no wall space on the latch side of a single door, or to the right side of double doors, signs shall be located on the nearest adjacent wall. Signs containing tactile characters shall be located so that a clear floor space of 455 mm × 455 mm minimum, centred on the sign, is provided beyond the arc of any door swing between the closed position and 45° open position.

Exception: Signs shall be permitted on the push side of doors with closers and without hold-open devices.

E.19.3 Tactile Characters

E.19.3.1

Where tactile characters are required, and separate tactile and visual characters with duplicate information are provided, tactile characters shall comply with Clauses E.19.3.2 to E.19.3.5 and visual characters shall comply with Clause E.19.4. Tactile characters shall be duplicated in Braille in accordance with Clause E.19.5.

E.19.3.2 Tactile character depth

Tactile characters shall be raised a minimum of 0.8 mm above the background.

E.19.3.3 Character forms

E.19.3.3.1

Fonts shall have characters complying with Clauses E.19.3.3.2 to E.19.3.3.7.

E.19.3.3.2 Case

Characters shall be uppercase.

E.19.3.3.3 Style

Characters shall be sans serif. Characters shall not be italic, oblique, script, highly decorative, or of other unusual form.

E.19.3.3.4 Width

Character width shall be 55% minimum and 110% maximum of the height of the character, with the width based on the uppercase letter O and the height based on the uppercase letter I.

E.19.3.3.5 Stroke thickness

Characters shall have a stroke thickness that is 15% maximum of the height of the character, based on the uppercase letter I.

E.19.3.3.6 Spacing

Spacing between individual characters shall be 3 mm minimum to 6 mm maximum. Spacing shall be calculated by measuring the two closest points between each adjacent character within a message, excluding spaces between words. Spacing between the baseline of separate lines of characters within a message shall be 135% minimum and 170% maximum of the character height.

E.19.3.3.7 Height

Character height, measured vertically from the baseline of the character, shall be 13 mm minimum, and 19 mm maximum, based on the uppercase letter I.

E.19.3.4 Mounting height

Characters shall be located 1 220 mm minimum and 1 525 mm maximum above the adjacent floor or ground surface, measured from the baseline of the characters, except for elevator car controls.

E.19.3.5 Mounting location

Where a tactile sign is provided at a door, the sign shall be located alongside the door on the latch side. Where a tactile sign is provided at double doors, the sign shall be located to the right of the right-hand door. Where there is no wall space on the latch side of a single door, or to the right side of double doors, signs shall be located on the nearest adjacent wall. Signs containing tactile characters shall be located so that a clear floor space of 455 mm × 455 mm minimum, centred on the sign, is provided beyond the arc of any door swing between the closed position and 45° open position.

Exception: Door-mounted signs shall be permitted on the push side of doors with closers and without hold-open devices.

E.19.4 Visual characters

E.19.4.1 General

Visual characters required to be accessible shall comply with Clauses E.19.4.2 and E.19.4.3.

E.19.4.2 Finish and contrast

Characters and backgrounds shall have a non-glare finish. Characters shall contrast with the background: either light characters shall appear on a dark background or dark characters shall appear on a light background.

E.19.4.3 Character forms

E.19.4.3.1 General

Visual characters required to be accessible shall comply with Clauses E.19.4.2 and E.19.4.3.

E.19.4.3.2 Case

Characters shall be uppercase and/or lowercase.

E.19.4.3.3 Style

Characters shall be conventional in form. Characters shall not be italic, oblique, script, highly decorative, or of other unusual form.

E.19.4.3.4 Width

Character width shall be 55% minimum and 110% maximum the height of the character, with the width based on the uppercase O, and the height based on the uppercase I.

E.19.4.3.5 Stroke thickness

Characters shall have a stroke thickness that is 10% minimum and 30% maximum of the height of the character, based on the uppercase letter I.

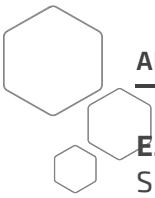

E.19.4.3.6 Spacing

Spacing between individual characters shall be 10% minimum and 35% maximum of character height. Spacing shall be calculated by measuring the two closest points between each adjacent character within a message, excluding spaces between words. Spacing between the baseline of separate lines of characters within a message shall be 135% minimum and 170% maximum of the character height.

E.19.4.3.7 Height

Minimum character height, measured from the baseline of the character, shall comply with Clause E.4.4. based on the height of the characters above the finished floor of the viewing location and the minimum viewing distance. Character height shall be based on the uppercase letter I. Minimum viewing distance shall be the horizontal distance where an obstruction prevents further approach toward the sign.

E.19.5 Braille

E.19.5.1 General

Tactile characters shall be accompanied by Grade II Braille complying with Clauses E.19.5.2 to E.19.5.4 and Table E.19.5 Braille dots shall have a domed or rounded shape.

Measurement range for	Minimum	Maximum
Dot base diameter	1.5 mm	1.5 mm
Distance between any two dots in same cell, centre to centre	2.3 mm	2.5 mm
Distance between corresponding dots in adjacent cells, centre to centre	6.1 mm	7.6 mm
Dot height	0.6 mm	0.8 mm
Distance between corresponding dots from one cell to the cell directly below, centre to centre	10.0 mm	10.1 mm

E.19.5.2 Location

Braille shall be located below the corresponding text. If text is multi-lined, Braille shall be placed below entire text. Braille shall be separated 10 mm minimum from any other tactile characters. Braille provided in accordance with Figure 4.10.1.12 shall be separated 5 mm minimum either directly below or adjacent to the corresponding raised characters or symbols.

E.19.5.3 Height

Braille shall be located 1 015 mm minimum and 1 525 mm maximum above the finished floor, measured from the baseline of the Braille cells, except for elevator car controls.

E.19.5.4 Braille standard

Braille shall be in accordance with literary Braille, except that the indication of an uppercase letter or letters shall only be used before the first word of sentences, proper nouns and names, individual letters of the alphabet, initials, or acronyms.

E.19.6 Identifying pictograms

E.19.6.1 General

Where pictograms are required to be accessible, they shall comply with Clauses E.19.6.2 to E.19.6.4.

E.19.6.2 Pictogram field

Pictograms shall have a field with a height of 150 mm minimum. Characters and/or Braille shall not be located in the pictogram field.

E.19.6.3 Finish and contrast

Pictograms and their fields shall have a non-reflective finish. Pictograms shall contrast with their fields: either a light pictogram shall appear on a dark field or a dark pictogram shall appear on a light field.

E.19.6.4 Text descriptors

Where text descriptors for pictograms are required, they shall be located directly below or adjacent to the pictogram and shall comply with Clause E.19.2.

E.19.7 Symbols of accessibility

E.19.7.1 Finish and contrast

Symbols of accessibility and their backgrounds shall have a non-glare finish. Symbols of accessibility shall contrast with their backgrounds: either a light symbol shall appear on a dark background or a dark symbol shall appear on a light background.

E.19.7.2 Symbols

E.19.7.2.1 International symbol of accessibility

Where the international symbol of accessibility is required, it shall be proportioned as shown in Fig. E-19.7.2.1.

E.19.7.2.2 International symbol of a text telephone (TTY)

Where the international symbol of text telephones is required, it shall be proportioned as shown in Fig. E-19.7.2.2.

E.19.7.2.3 Assistive listening systems

Where assistive listening systems are required to be identified by the international symbol of access for hearing loss, it shall be proportioned as shown in Fig. E-19.7.2.3.

E.19.7.2.4 Volume-controlled telephones

Where telephones with volume controls are required to be identified, the identification symbol shall be a telephone handset with radiating sound waves as shown in Fig. E-19.7.2.4.

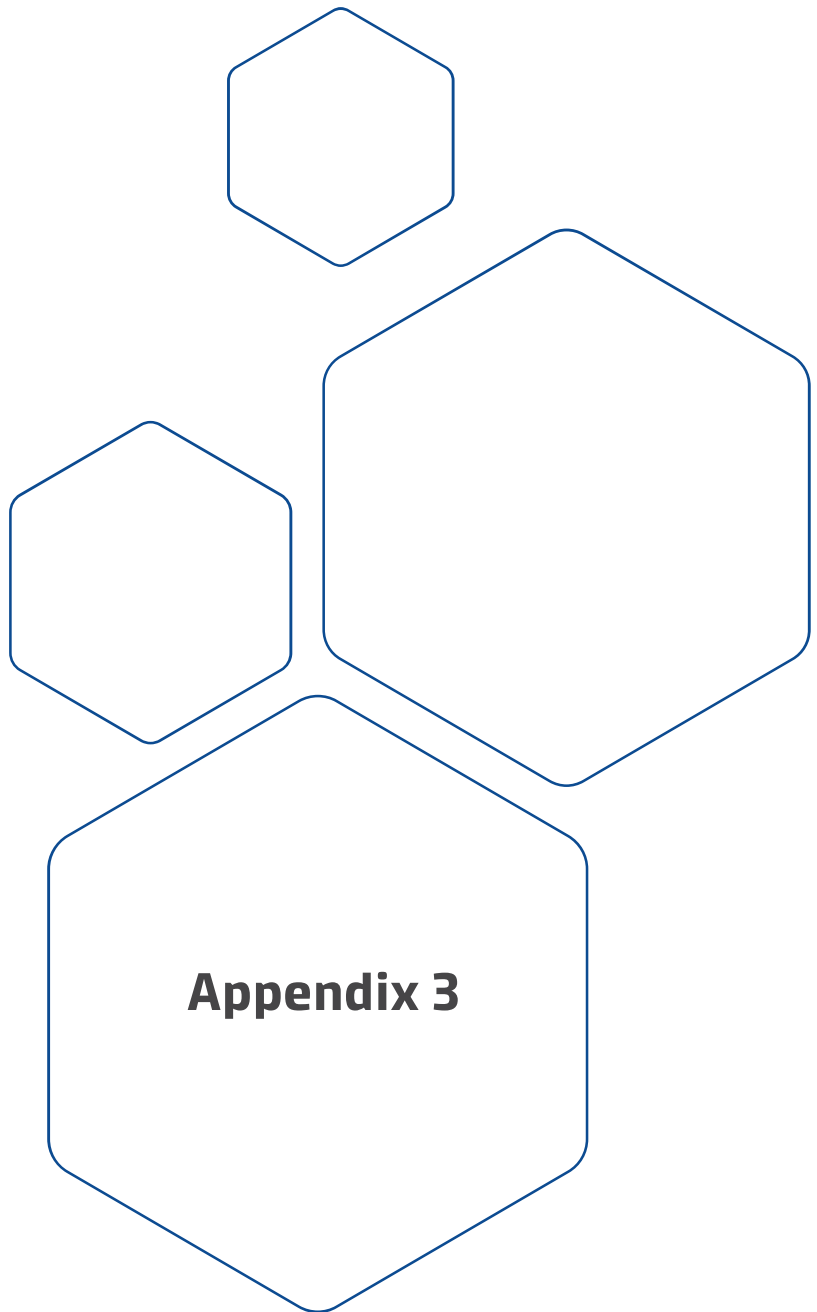

Appendix 3

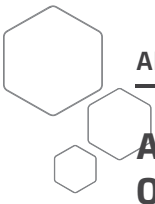

APPENDIX 3 Occupancy Types

1.3.3. Application of Division B

1.3.3.1. Application of Parts 1, 7 and 8

4) Parts 1, 7, and 8 of Division B apply to all buildings covered in this Code. (See Article 1.1.1.1.)

1.3.3.2. Application of Parts 3, 4, 5 and 6

- Parts 3, 4, 5, and 6 of Division B apply to all buildings described in Article 1.1.1.1. and
 - o classified as post-disaster buildings,
 - o used for major occupancies classified as
 - Group A, assembly occupancies,
 - Group B, care or detention occupancies, or
 - Group F, Division 1, high-hazard industrial occupancies, or
 - o exceeding 600 m² in building area or exceeding 3 storeys in building height used for major occupancies classified as
 - Group C, residential occupancies,
 - Group D, business and personal services occupancies,
 - Group E, mercantile occupancies, or
 - Group F, Divisions 2 and 3, medium- and low-hazard industrial occupancies.

1.3.3.3. Application of Parts 9, 10 and 11

- Part 9 of Division B applies to all buildings described in Article 1.1.1.1. of 3 storeys or less in building height, having a building area not exceeding 600 m², and used for major occupancies classified as
 - o Group C, residential occupancies (see Appendix Note A-9.1.1.1.(1) of Division B),
 - o Group D, business and personal services occupancies,
 - o Group E, mercantile occupancies, or
 - o Group F, Divisions 2 and 3, medium- and low-hazard industrial occupancies.



**Safety
Codes
Council**